

Oneida Nation

Post Office Box 365

Phone: (920)869-2214



Oneida, WI 54155

BC Meeting Materials April 27, 2017

Open Session

CERTIFICATION

I, the undersigned, as Secretary of the Oneida Business Committee, hereby certify that the following 263 pages are the Open Session meeting materials presented at a meeting duly called, noticed and held on the 27th day of April, 2017.

A handwritten signature in blue ink that reads "Lisa Summers". The signature is written in a cursive style and is positioned above a horizontal line.

Lisa Summers, Tribal Secretary
Oneida Business Committee



Oneida Business Committee

FY '17 2nd Quarterly Reports
 8:00 a.m. Thursday, April 27, 2017
 BC Conference Room, 2nd floor, Norbert Hill Center

Agenda

To get a copy of the agenda, go to: oneida-nsn.gov/government/business-committee/agendas-packets/

I. CALL TO ORDER AND ROLL CALL

II. OPENING

III. ADOPT THE AGENDA

pp. 1-4

IV. REPORTS *(Please Note: Scheduled times are approximate and subject to change)*

A. APPOINTED BOARDS, COMMITTEES, COMMISSIONS

1. **Accept Oneida Nation Arts Board FY '17 2nd quarter report (8:00 a.m.)** pp. 5-9
 Chair: Tamara VanSchyndel
 Liaison: Jennifer Webster, Councilwoman
2. **Accept Anna John Residential Centered Care Community Board FY '17 2nd quarter report (8:15 a.m.)** pp. 10-13
 Chair: Candace House
 Liaison: Melinda J. Danforth, Tribal Vice-Chairwoman
3. **Accept Oneida Child Protective Board FY '17 2nd quarter report (8:30 a.m.)** pp. 14-18
 Chair: Dale Powless
 Liaison: Lisa Summers, Tribal Secretary
4. **Accept Oneida Environmental Resources Board FY '17 2nd quarter report (8:45 a.m.)** pp. 19-23
 Chair: Marlene Garvey
 Liaison: Tehassi Hill, Councilman
5. **Accept Oneida Community Library Board FY '17 2nd quarter report (9:00 a.m.)** pp. 24-27
 Chair: Dylan Benton
 Liaison: Fawn Billie, Councilwoman
6. **Accept Oneida Personnel Commission FY '17 2nd quarter report (9:15 a.m.)** pp. 28-52
 Chair: Yvonne Jourdan
 Liaison: Lisa Summers, Tribal Secretary

**a. Accept revised Oneida Personnel Commission FY '17 1st quarter report
(Not Submitted)**

EXCERPT FROM FEBRUARY 8, 2017: (1) Motion by Fawn Billie to accept the verbal update from the Oneida Personnel Commission, seconded by Tehassi Hill. Motion carried with one abstention. (2) Motion by Brandon Stevens to request the Tribal Secretary and Councilman David Jordan to send a letter regarding Oneida Personnel Commission processing separate reports, one for executive session and one for open session, seconded by David Jordan. Motion carried with one abstention. (3) Motion by Fawn Billie to request Councilman David Jordan to work with the Tribal Secretary to provide notice to the Oneida Personnel Commission that the Parks and Recreation complaint has been closed-out, seconded by David Jordan. Motion carried with one abstention.

EXCERPT FROM JANUARY 26, 2017: Motion by Trish King to defer this item back to the Oneida Personnel Commission to separate out the issues as discussed so we can address the Personnel Commission issues in executive session on February 7, 2017; and to defer the FY '17 1st quarter report to the next quarterly reports Business Committee meeting on April 27, 2017, seconded by Lisa Summers. Motion carried unanimously.

- 7. Accept Oneida Police Commission FY '17 2nd quarter report (9:30 a.m.)** pp. 53-61
Vice-Chair: Sandra Reveles
Liaison: Lisa Summers, Tribal Secretary
- 8. Accept Oneida Pow-wow Committee FY '17 2nd quarter report (9:45 a.m.)** pp. 62-72
Chair: Tonya Webster
Liaison: Fawn Billie, Councilwoman

(Break scheduled from 10:00 a.m. – 10:15 a.m.)

- 9. Accept Southeastern Oneida Tribal Services Advisory Board FY '17 2nd quarter report (10:15 a.m.)** pp. 73-76
Interim Chair: Peter Stevens
Liaison: Tina Danforth, Tribal Chairwoman

a. Accept Southeastern Oneida Tribal Services Advisory Board FY '17 1st quarter report pp. 77-80

EXCERPT FROM JANUARY 26, 2017: Motion by Jennifer Webster to defer the Southeastern Oneida Tribal Services Advisory Board FY '17 1st quarter report to the next quarterly reports Business Committee meeting on April 27, 2017; and to request Tribal Secretary Lisa Summers to follow-up with the Chair of the Southeastern Oneida Tribal Services Advisory Board, seconded by Lisa Summers. Motion carried unanimously.

- 10. Accept Oneida Nation Veterans Affairs Committee FY '17 2nd quarter report (10:30 a.m.)** pp. 81-87
Chair: Mike Hill
Liaison: Jennifer Webster, Councilwoman

B. ELECTED BOARDS, COMMITTEES, COMMISSIONS

- 1. Accept Oneida Nation Commission on Aging FY '17 2nd quarter report (10:45 a.m.)** pp. 88-97
Chair: Wes Martin Jr.
Liaison: Melinda J. Danforth, Tribal Vice-Chairwoman
- 2. Accept Oneida Gaming Commission FY '17 2nd quarter report (11:00 a.m.)** pp. 98-101
Chair: Mark A. Powless
Liaison: Brandon Stevens, Councilman

- 3. Accept Oneida Election Board FY '17 2nd quarter report (11:15 a.m.)** pp. 102-104
 Chair: Racquel Hill
 Liaison: Melinda J. Danforth, Tribal Vice-Chairwoman
- 4. Accept Oneida Land Claims Commission FY '17 2nd quarter report (11:30 a.m.)** pp. 105-109
 Chair: Loretta Metoxen
 Liaison: Brandon Stevens, Councilman

(Break scheduled from 11:45 p.m.-1:15 p.m.)

- 5. Defer Oneida Land Commission FY '17 2nd quarter report (1:15 p.m.)** pp. 110-111
 Chair: Rae Skenandore
 Liaison: Tehassi Hill, Councilman
- a. Accept Oneida Land Commission FY '17 1st quarter report** pp. 112-115
- EXCERPT FROM JANUARY 26, 2017: Motion by David Jordan to defer the Oneida Land Commission FY '17 1st quarter report to the next quarterly reports Business Committee meeting on April 27, 2017, seconded by Trish King. Motion carried unanimously.*
- 6. Accept Oneida Nation School Board FY '17 2nd quarter report (1:30 p.m.)** pp. 116-145
 Chair: Debra Danforth
 Liaison: Fawn Billie, Councilwoman

C. CORPORATE BOARDS

- 1. Accept Oneida Airport Hotel Corporation FY '17 2nd quarter report (1:45 p.m.)** pp. 146-151
 Agent: Janice Hirth-Skenandore
 Liaison: Trish King, Tribal Treasurer
- 2. Accept Oneida Golf Enterprise FY '17 2nd quarter report (2:00 p.m.)** pp. 152-156
 Agent: Janice Hirth-Skenandore
 Liaison: Trish King, Tribal Treasurer
- 3. Accept Bay Bancorporation, Inc. FY '17 2nd quarter report (2:15 p.m.)** pp. 157-161
 President: Jeff Bowman
 Liaison: Tina Danforth, Tribal Chairwoman
- 4. Accept Oneida ESC Group, LLC. FY '17 2nd quarter report (2:30 p.m.)** pp. 162-171
 Chair: Jackie Zalim
 Liaison: Tehassi Hill, Councilman
- 5. Accept Oneida Total Integrated Enterprises, LLC. FY '17 2nd quarter report (2:45 p.m.)** pp. 172-192
 Managing Principal: Jeff House
 Liaison: Tehassi Hill, Councilman
- 6. Accept Oneida Seven Generations Corporation FY '17 2nd quarter report (3:00 p.m.)** pp. 193-196
 Agent: Pete King III
 Liaison: Tina Danforth, Tribal Chairwoman

(Break scheduled from 3:15 p.m.- 3:30 p.m.)

D. STANDING COMMITTEES

1. **Accept Community Development Planning Committee FY '17 2nd quarter report (3:30 p.m.)** pp. 197-205
Chair: Melinda J. Danforth, Tribal Vice-Chairwoman
 - a. **Accept Community Development Planning Committee FY '17 1st quarter report** pp. 206-220

EXCERPT FROM JANUARY 26, 2017: Motion by Lisa Summers to defer the Community Development Planning Committee FY '17 1st quarter report to the next quarterly reports Business Committee meeting on April 27, 2017, seconded by David Jordan. Motion carried unanimously.
2. **Accept Legislative Operating Committee FY '17 2nd quarter report (3:45 p.m.)** pp. 221-226
Chair: Brandon Stevens, Councilman
3. **Accept Quality of Life Committee FY '17 2nd quarter report (4:00 p.m.)** pp. 227-229
Chair: Fawn Billie, Councilwoman
4. **Accept Finance Committee FY '17 2nd quarter report (4:15 p.m.)** pp. 230-235
Chair: Trish King, Tribal Treasurer

V. ADJOURN

Posted on the Oneida Nation's official website, www.oneida-nsn.gov, at 1:45 p.m., Friday, April 21, 2017, pursuant to the Open Records and Open Meetings Law, section 7.17-1.

The meeting packet of the open session materials for this meeting is available by going to the Oneida Nation's official website at: <https://oneida-nsn.gov/government/business-committee/agendas-packets/>

For information about this meeting, please call the Business Committee Support Office at (920) 869-4364 or (800) 236-2214.

Oneida Business Committee Agenda Request

1. Meeting Date Requested: 04 / 27 / 17

2. General Information:

Session: Open Executive - See instructions for the applicable laws, then choose one:

Agenda Header:

Accept as Information only

Action - please describe:

Accept Oneida Nation Arts Board FY '17 2nd quarter report

3. Supporting Materials

Report Resolution Contract

Other:

1.

3.

2.

4.

Business Committee signature required

4. Budget Information

Budgeted - Tribal Contribution

Budgeted - Grant Funded

Unbudgeted

5. Submission

Authorized Sponsor / Liaison:

Primary Requestor/Submitter:

Tamara VanSchyndel, Chair/Oneida Nation Arts Board

Your Name, Title / Dept. or Tribal Member

Additional Requestor:

Name, Title / Dept.

Additional Requestor:

Name, Title / Dept.

Oneida Business Committee Agenda Request

6. Cover Memo:

Describe the purpose, background/history, and action requested:

Accept Oneida Nation Arts Board FY '17 2nd quarter report

1) Save a copy of this form for your records.

2) Print this form as a *.pdf *OR* print and scan this form in as *.pdf.

3) E-mail this form and all supporting materials in a **SINGLE** *.pdf file to: BC_Agenda_Requests@oneidanation.org

Oneida Nation Arts Board

Quarterly Report – 2nd Quarter (January - March, 2017)

April 27, 2017

Oneida Nation Arts Board (ONAB)

Tamara VanSchyndel (Exp. 2017)

Sylvia Cornelius (Exp. 2018)

Dakota Webster (Exp. 2018)

Jackie Zalim (Exp. 2018)

Pat Moore, Secretary (Exp. 2018)

Marena Bridges (Exp. 2019)

Dawn Walchinski (Exp. 2019)

Desirae Louise Hill (Exp. 2020)

Report submitted by:

Tamara VanSchyndel, Chair (Exp. 2017)

Beth Bashara, ONAP/CEC Director



Board Purpose Statement:

To provide guidance to the Oneida Nation Arts Program (ONAP) and to perform the responsibilities granted to the Board under the Dollars for Arts Program policy. Specific responsibilities include, but are not limited to the following: (a) work with ONAP Director and staff in an advisory capacity on issues related to the arts in Oneida, (b) strive to provide guidance and recommendations in the development of the ONAP and arts programs throughout the community, (c) receive reports of the ONAP activities ONAP staff, (d) evaluate ONAP, and (e) approve policies and programs for the overall coordination and administration of the ONAP.

Update from the Chair

In February, ONAB validated the current mission and brainstormed potential objectives for the year. Additionally, the Music of Our Culture Board (MOC) was officially recognized as an ad hoc board of the ONAB. A memorandum of agreement is being developed to document agreed upon expectations and how the boards will work together.

In April, the ONAB and MOC Boards, joined by the Woodland Indian Arts Board (WIAB), participated in a discussion facilitated by Anne Katz, the Executive Director of the Wisconsin Arts organization. The discussion focused on possibilities and expectations for board relationships.

The ONAB is aware of potential reorganization of the ONAP, as well as the CEC, which the ONAP Director currently oversees. It is the ONAB's expectation they be notified and included in the dialogue and approval of any reorganization that affects the areas of responsibility of the ONAP/CEC Director.

Meetings Held

February 7, 2017

ONAB quorum joined by MOC Board Chairwoman

April 4, 2017

ONAB, MOC Board and WIAB facilitated discussion (no quorum)

Oneida Nation Arts Program Update

Administrative Reports: Beth Bashara, Director; Christine Klimmek, Program Coordinator; Sherrole Benton, Program Coordinator

Programming Reports

Grants: Bashara was awarded a \$10,000 grant from the NEA for a 2017 Native song writing workshop. The proposal brings prominent Native song writers to Oneida to compose and record for 5 days, with the agreement that the songs may be arranged for choirs.

HRD: Bashara has worked with HRD to brainstorm better ways of hiring students (interns), classifying them as “sub relief” rather than “emergency temp.” The change would allow for greater flexibility in the length of time someone could work (ET – 3 months only) and maintaining a pool (SR is a pool position so you can bring more people on if you need more people).

WAB Grant for the Fringe: Sherrole finished the program booklet from the Bead Conference in September. It was very well received.

Classes: The basket making class is filled. Christine offered a second series of water color classes because of the interest.

SEEDS: Artists are meeting with Kim Wurst from the CEC who is now managing the program. Kim is working with artists to streamline and unify the marketing materials. We are excited to see the additional changes.

Future Focus

Arts Made Public:

MONDAY-FRIDAY June 26-June 30, 1 pm-5 pm

9-13 Yrs.

Location: Arts Cottage

Fee: \$30, \$10 Scholarship Fee

Unity Singers Camp

MONDAY-THUR July 24-July 27, 1 pm-5 pm

13-17 Yrs.

Location: Arts Cottage

Fee: \$30, \$10 Scholarship Fee

MOC Camp

MONDAY-THUR July 31-Aug 10, 1 pm-5 pm

7-12 Yrs.

Location: Arts Cottage

Fee: \$30, \$10 Scholarship Fee

10 Reasons to Invest in Wisconsin's Creative Sector

From Arts Wisconsin at <http://www.artswisconsin.org/actioncenter/facts-and-figures/10-reasons/>

- 1. Arts promote true prosperity.** The arts help us express our values, build bridges between cultures, and bring us together regardless of ethnicity, religion, or age. When times are tough, art is salve for the ache.
- 2. Arts mean business.** The Creative Industries are arts businesses that range from nonprofit museums, symphonies, and theaters to for-profit film, architecture, and design companies. A 2015 analysis of Dun & Bradstreet data counts 9,985 businesses in Wisconsin involved in the creation or distribution of the arts that employ 42,183 people—representing 3.2 percent of the state's businesses and 1.4 percent of its employees.
- 3. Arts strengthen the economy.** The U.S. Bureau of Economic Analysis reports that the arts and culture sector is a \$730 billion industry, representing 4.2% of the GDP ((Gross Domestic Project). The sector packs a larger punch for the economy than tourism, transportation and agriculture.
- 4. Arts are good for local merchants.** Attendees at Wisconsin's nonprofit arts events spend \$19.06 per person, per event, beyond the cost of admission on items such as meals, parking, and babysitters. Nine percent of the 9.4 million nonprofit arts attendees come from outside of Wisconsin. Those 806,000 attendees spend nearly twice as much as residents (\$33.02 vs. \$17.73).
- 5. Arts drive tourism.** Arts travelers are ideal tourists, staying longer and spending more to seek out authentic cultural experiences. The U.S. Department of Commerce reports that the percentage of international travelers including museum visits on their trip has grown steadily since 2003 (18 to 28 percent). The share attending concerts and theater performances has grown from 14 to 18 percent since 2003.
- 6. Arts are an export industry.** U.S. exports of arts goods (e.g., movies, paintings, jewelry) grew to \$75 billion in 2012, while imports were just \$27 billion—a \$47 billion arts trade surplus.
- 7. Arts spark creativity and innovation.** The Conference Board reports that creativity is among the top 5 applied skills sought by business leaders—with 72 percent saying creativity is of high importance when hiring. The biggest creativity indicator? A college arts degree. Their *Ready to Innovate* report concludes, “The arts—music, creative writing, drawing, dance—provide skills sought by employers of the 3rd millennium.” Nobel laureates in the sciences are 17 times more likely to be actively engaged in the arts than average scientists.
- 8. Arts have social impact.** University of Pennsylvania researchers have demonstrated that a high concentration of the arts in a city leads to higher civic engagement, more social cohesion, higher child welfare, and lower crime and poverty rates. The arts are used by the U.S. Military to promote troop force and family readiness, resilience, retention and for the successful reintegration of veterans into family and community life.
- 9. Arts improve academic performance.** Students with an education rich in the arts have higher GPAs and standardized test scores, and lower drop-out rates—benefits reaped by students regardless of socio-economic status. Students with 4 years of arts or music in high school average 100 points higher on the verbal and math portions of their SATs than students with just one-half year of arts or music.
- 10. Arts improve healthcare.** Nearly one-half of the nation's healthcare institutions provide arts programming for patients, families, and even staff. 78 percent deliver these programs because of their healing benefits to patients—shorter hospital stays, better pain management, and less medication.

Oneida Business Committee Agenda Request

1. Meeting Date Requested: 04 / 27 / 17

2. General Information:

Session: Open Executive - See instructions for the applicable laws, then choose one:

Agenda Header:

Accept as Information only

Action - please describe:

PLEASE ACCEPT THE AJRCCC SECOND QUARTERLY REPORT FOR 2017. THIS REPORT COVERS THE PERIOD OF JANUARY, FEBRUARY AND MARCH 2017.

3. Supporting Materials

Report Resolution Contract

Other:

1.

3.

2.

4.

Business Committee signature required

4. Budget Information

Budgeted - Tribal Contribution Budgeted - Grant Funded Unbudgeted

5. Submission

Authorized Sponsor / Liaison:

Primary Requestor/Submitter: CANDACE HOUSE, CHAIRPERSON CAROL ELM, VICE CHAIRPERSON
Your Name, Title / Dept. or Tribal Member

Additional Requestor: PAT MOORE, YVONNE CORNELIUS, JANICE MCLESTER, MARY ADAMS, SANDRA
Name, Title / Dept.

Additional Requestor: SKENADORE- BOARD MEMBERS
Name, Title / Dept.

Oneida Business Committee Agenda Request

6. Cover Memo:

Describe the purpose, background/history, and action requested:

PER THE TRIBAL SECRETARY'S OFFICE SCHEDULE -- ALL BOARDS, COMMITTEES, AND COMMISSIONS ARE TO PROVIDE QUARTERLY REPORTS TO THE ONEIDA BUSINESS COMMITTEE. 2ND QUARTER REPORT OF THE AJRCCC DUE ON APRIL 18, 2017 FOR THE APRIL 27, 2017 MEETING DATE.

1) Save a copy of this form for your records.

2) Print this form as a *.pdf *OR* print and scan this form in as *.pdf.

3) E-mail this form and all supporting materials in a **SINGLE** *.pdf file to: BC_Agenda_Requests@oneidanation.org



**Anna John Resident Centered Care Community (AJRCCC)
 Second Quarter Report to Business Committee
 Period: January, February, March 2017
 Submitted by: Candace House - Chairwoman**

The purpose of the Anna John Resident Centered Care Community (AJRCCC) Board is to serve in an advisory capacity ensuring operations of AJRCCC are within the guidelines and policies of the Oneida Nation and within all regulations, rules, policies governing the operation of a nursing home.

The Board ensures the AJRCCC maintains a safe and sanitary environment while providing quality care and services to residents of the facility and as ordered by each resident’s attending physician.

AJRCCC BOARD MEMBERS

Name	Term Expires	Name	Term Expires
Carol Elm	1/28/18	Pat Moore	5/27/18
Yvonne Cornelius	11/12/17	Candace House	1/28/18
Janice McLester	7/8/18	Mary Adams	7/25/17
Sandra Skenadore	11/12/17		

2017 MEETINGS

January	February	March
NONE	February 8, 2017-Reg	March 15, 2017-Reg March 29, 2017-Spc

2017 RESIDENT CENSUS

January – 45	February – 45	March – 43
---------------------	----------------------	-------------------

Maximum is 48 Beds

HIGHLIGHTS

- Dave Larson is currently the Interim Administrator for the AJRCCC.
- The Finance Coordinators have been doing an excellent job in submission and recoupment of third party revenues for the facility and have made tremendous progress in collections.

MONTHLY ACTIVITIES – January 2017

AJRCCC is nearing its capacity as far as census. On most days, AJRCCC has only 2-3 beds open and there continues to be a waiting list for long term care. With a limited number of beds open, the revenue stream should remain constant but will not see any major increase in the near future. Most of the patient charts have been converted to electronic format, and electronic scanning of medications have been instituted in late January.

MONTHLY ACTIVITIES – February 2017

The Improving Medicare Post-Acute Care Transformation (IMPACT) Act of 2014 went into effect October 1, 2016. It established a 2% withhold to SNF Part A payments that can be partially earned back based on a SNF's re-hospitalization rate and level of improvement. This includes hospital readmissions from the facility prior to discharge and from home after discharge. This means that our Medicare PART A payments are automatically reduced by 2%. If our readmission rates are not too high we get the 2% back.

MONTHLY ACTIVITIES – March 2017

The State has received phase 1 of a grant from CMS for the Money Follows the Person – Tribal Initiative. The WI Department of Health Services will be administering the grant and each Tribe will receive \$75,000. This funding is to help the Tribes build the infrastructure to enable them to provide community based long term care services and supports. We intend to use the grant for setting up the integrated case management system and a personal care agency. Some of the funding will be available for training. We are finalizing plans to have the Health Center Pharmacy provide the resident medications for AJRCCC. This will result in significant cost savings compared to contracting with an outside pharmacy for these services as we currently do.

The End.

Oneida Business Committee Agenda Request

1. Meeting Date Requested: 4 / 27 / 17

2. General Information:

Session: Open Executive - See instructions for the applicable laws, then choose one:

Agenda Header:

Accept as Information only

Action - please describe:

Approval needed

3. Supporting Materials

Report Resolution Contract

Other:

1.

3.

2.

4.

Business Committee signature required

4. Budget Information

Budgeted - Tribal Contribution Budgeted - Grant Funded Unbudgeted

5. Submission

Authorized Sponsor / Liaison:

Primary Requestor/Submitter:
Your Name, Title / Dept. or Tribal Member

Additional Requestor: _____
Name, Title / Dept.

Additional Requestor: _____
Name, Title / Dept.

Oneida Business Committee Agenda Request

6. Cover Memo:

Describe the purpose, background/history, and action requested:

Requesting approval for 2nd quarter report for the Oneida Child Protective Board.

1) Save a copy of this form for your records.

2) Print this form as a *.pdf *OR* print and scan this form in as *.pdf.

3) E-mail this form and all supporting materials in a **SINGLE** *.pdf file to: BC_Agenda_Requests@oneidanation.org

Oneida Child Protective Board Quarterly Report
For Oneida Business Committee
Period: January, February, & March 2017
Second Quarter report due: April 18th, 2017

ONEIDA CHILD PROTECTIVE BOARD

Dale Powless, Chairman
Lois Strong, Vice Chair
Jeanette Ninham, Secretary
Beverly Anderson, Member

Wesley Martin, Member
Carol Silva, Member
Melinda K. Danforth, Member
Lisa Summers, OBC Liaison

MISSION: To secure a stable environment that includes the physical, mental, cultural and financial well-being of Oneida children.

PURPOSE: In accordance with the Indian Child Welfare Act, 25 U.S.C. 1901, etseq. , the purpose of the Board is to protect the best interest of Oneida children and to promote the stability and security of Oneida families. When placements of such children in foster or adoptive homes or facilities are necessary, these homes must reflect the unique values of Indian culture. For this purpose, the Board may intervene in federal, state, and county courts concerning the following proceedings: foster care placement, termination of parental rights, pre-adoptive placement, adoptions and out of home placements.

MEETING REQUIREMENTS

Oneida Child Protective Board meets weekly and by special requests from family members, counties departments, or community members.

MINUTES

Due to confidentiality nature of minors, all minutes are kept in locked fireproof file cabinet, in a locked room within the building.

FINANCIALS

The Oneida Child Protective Board is on schedule with meeting our financial goals.

EDUCATION/TRAINING

- Adoption Tax Credit
January 31st, 2017
- Self-Regulation in Children
March 8th, 2017
- ICW Directors Meeting
March 22nd & 23rd, 2017

Oneida Child Protective Board Quarterly Report
For Oneida Business Committee
Period: January, February, & March 2017
Second Quarter report due: April 18th, 2017

- The Power of Non-Verbal Cues & Body Language
March 31st, 2017

GOALS AND OBJECTIVES

- Facilitate appropriate training opportunities for Oneida Child Protective Board members for certificate/report of completion per Oneida Child Protective Board Bylaws.
- Develop working relationship and improve judicial relationships through meetings with tribal, state, and county personnel.
- Work in accordance with the Oneida Law Office and Tribal Social services to enforce the provisions of the Indian Child Welfare Act.

COMMENTS

- Met with family members to hear concerns of county workers/ICW/attorneys.
- Request for assistance for family Adoption. Direction on where to start and get information from.
- Contacted ICWA Director on foster home concerns, when the workers could not be contacted
- Heard, discussed and recommended the best solution for cases that came before us. The following chart demonstrates the approximate number of cases for the quarter:

Oneida Child Protective Board Quarterly Report
 For Oneida Business Committee
 Period: January, February, & March 2017
 Second Quarter report due: April 18th, 2017

January	
<i>On-Going Cases</i>	25
<i>New Cases</i>	6
<i>Relative Placement</i>	23
<i>Future Adoptive Placement</i>	-
<i>Treatment Facility Placement</i>	-
<i>Shelter Care Placement</i>	1
<i>Foster Care Placement</i>	6
<i>Parent Placement</i>	-
<i>Fictive Kin</i>	-
<i>Guardianship</i>	-
<i>Kinship</i>	-

February	
<i>On-Going Cases</i>	38
<i>New Cases</i>	4
<i>Relative Placement</i>	36
<i>Future Adoptive Placement</i>	-
<i>Treatment Facility Placement</i>	2
<i>Shelter Care Placement</i>	-
<i>Foster Care Placement</i>	3
<i>Parent Placement</i>	2
<i>Fictive Kin</i>	-
<i>Guardianship</i>	2
<i>Kinship</i>	-

March	
<i>On-Going Cases</i>	41
<i>New Cases</i>	-
<i>Relative Placement</i>	30
<i>Future Adoptive Placement</i>	-
<i>Treatment Facility Placement</i>	-
<i>Shelter Care Placement</i>	1
<i>Foster Care Placement</i>	7
<i>Parent Placement</i>	2
<i>Fictive Kin</i>	1
<i>Guardianship</i>	2
<i>Kinship</i>	2

Oneida Business Committee Agenda Request

1. Meeting Date Requested: 04 / 27 / 17

2. General Information:

Session: Open Executive - See instructions for the applicable laws, then choose one:

Agenda Header:

Accept as Information only

Action - please describe:

Request a motion to accept the Environmental Resource Board 2nd quarter report.

3. Supporting Materials

Report Resolution Contract

Other:

1.

3.

2.

4.

Business Committee signature required

4. Budget Information

Budgeted - Tribal Contribution

Budgeted - Grant Funded

Unbudgeted

5. Submission

Authorized Sponsor / Liaison:

Primary Requestor/Submitter:

Marlene "Minnie" Garvey, Chairwoman/Environmental Resource Board
Your Name, Title / Dept. or Tribal Member

Additional Requestor:

Chad Wilson, Project Manager/ERB
Name, Title / Dept.

Additional Requestor:

Name, Title / Dept.

Oneida Business Committee Agenda Request

6. Cover Memo:

Describe the purpose, background/history, and action requested:

Required quarterly reporting for fiscal year 2017.

- 1) Save a copy of this form for your records.
- 2) Print this form as a *.pdf *OR* print and scan this form in as *.pdf.
- 3) E-mail this form and all supporting materials in a **SINGLE** *.pdf file to: BC_Agenda_Requests@oneidanation.org

ENVIRONMENTAL RESOURCE BOARD

FY '17 2nd Quarter Report: January, February, March

ERB MEMBERSHIP

Marlene Garvey, Chair	Al Manders, Vice-Chair	Megan White, Secretary
Shawn Skenandore	Ted Hawk	Gerald Jordan
Tom Oudenhoven	Richard Baird	Nicole Steeber

Oneida Business Committee Liaison: Councilman Tehassi Hill

MINUTES

Action Taken January 5:

- No motions made.

Hearing on January 19:

- Citation hearings regarding violations of Domestic Animals Ordinance & Hunting, Fishing, and Trapping Law.

Action Taken February 2:

- Motion to accept updated changes to the Hunting, Fishing and Trapping regulations & sanctions and approve to move them to public hearing after review by attorneys Krystal John and Kelly McAndrews.
- Motion to accept the draft of the Onyota'a:ka Lake Internal Security Agreement and approve moving the agreement forward with Conservation to the Law Office.
- Motion to retro approve the ERB FY '17 1st Quarter Report.
- Motion to approve a letter of support for the Twahwatshi'lay Project for at-risk youth.

Action Taken March 2

- Motion to compile/develop a presentation regarding the ERB Director position and bring back to ERB.
- Motion to support Conservation to take steps as needed regarding geese populations at Thornberry Creek in anticipation for LPGA event.

Hearing on March 16

- Citation hearings regarding violation of Domestic Animals Ordinance.

FINANCIALS

Tribal Contribution	\$ 258,910.00
Period 04 January	\$ 23,057.10
Period 05 February	\$ 16,727.38
Period 06 March	\$ 16,397.09

SUMMARY OF ACTIVITIES

- Environmental Resource Board holds ***citation hearings*** to ensure the enforcement of health and safety measures for the Oneida community and by approving by decision any negotiated stipulations and agreements.
- Continue development of ***citation database*** for improved tracking and collection of citations and associated fines related to Oneida Hunting, Fishing, and Trapping Law; Domestic Animals Ordinance, and Public Use of Tribal Lands Law.
- Finalize work on ***Hunting, Fishing, and Trapping Regulations*** to streamline law and separate regulations from the law; and attendance at public hearing for the law. Also work on revamping the ***Fine and Penalty Schedule*** for violations of regulations and law.
- Assist in creating Standard Operation Procedures, Workflows, and Resolutions for ***Constitutional Amendments Implementation Team***.
- Communication on ***Public Use of Tribal Lands*** law and promotion of natural areas for community use.
- ***Onyota'a:ka Lake*** management activities, planning for Phase II, annual report draft, and review additional recreation amenities.
- Review of ***Cemetery Law Amendments*** for promulgating rules concerning prohibited uses of Oneida Nation cemetery grounds.
- Review of ***2017 Harvest Totals*** for deer including trends for licenses, harvest ratio, elder permits, season totals, and non-member harvest.
- Develop alternatives for funding ***ERB Training*** which is mandatory according to ERB by-laws for Environmental Law; Grievance, Hearing, and Appeals; Professional Ethics, and Robert's Rules of Order.
- ***Silver Creek Project Team*** coordination meetings for implementation of non-point strategies to reduce phosphorous inputs to watershed and streams from agricultural fields.
- Planning for ***Oneida Earth Day, Oneida Youth & Elder Fishing Day***, and Just Move it Oneida walks at Onyota'a:ka Lake.
- Review of ***Transportation Alternative Program*** funding (Surface Transportation Program) for FY2018 grants for continued community trails expansion.
- Other ***interdepartmental team*** activities or coordination efforts that arise on a short-term basis to meet the vision of the Oneida Nation.

GOALS

#	GOAL STATEMENT
1	Drafting of the Hunting, Fishing, and Trapping Regulations and Fine and Penalty Schedule along with accompanying Summary Report, Financial Analysis, and Public Meeting notice.
2	Monitor environmental and other projects for compliance with community goals, support Sustainable Community development projects and energy efficiency program development, and appropriately manage grant commitments.
3	Provide the Oneida community with environmental education through community events and educational outreach with emphasis on access to Oneida public lands, natural resource management, and water protection.

OBJECTIVES

#	OBJECTIVE STATEMENT	MEASUREMENT	COMPLETION DATE	GOAL # (above)
1	Drafting of regulations and creation of fine and penalty schedule to accompany the Hunting, Fishing, and Trapping law.	Approval of the regulations and fine schedule.	May, 2017	1
2	Citations Database to better manage and track violations and fine payments.	Interdepartmental coordination (OPD, Law, & Conservation)	March, 2017	2
3	Hearing body for citations issued for Hunting, Fishing, and Trapping Law and Domestic Animals ordinance.	Providing a reliable and dependable hearing structure	4 citations held/ agreements signed.	3

MEETING REQUIREMENTS

The ERB currently holds meetings once a month. Meetings are normally held on the 1st Thursday of each month. Hearings are held as required. ERB also attends Business Committee meetings, other public meetings, and performs volunteer service in the community as required or deemed appropriate by the ERB. **Yaw^ko!**

Oneida Business Committee Agenda Request

1. Meeting Date Requested: 04 / 27 / 17

2. General Information:

Session: Open Executive - See instructions for the applicable laws, then choose one:

Agenda Header:

Accept as Information only

Action - please describe:

Motion to accept Oneida Library Quarterly Report for Jan. Feb. March 2017

3. Supporting Materials

Report Resolution Contract

Other:

1.

3.

2.

4.

Business Committee signature required

4. Budget Information

Budgeted - Tribal Contribution Budgeted - Grant Funded Unbudgeted

5. Submission

Authorized Sponsor / Liaison:

Liaison: Fawn Billie

Primary Requestor:

Dr. Carol A. Cornelius, secretary Oneida Library Board

Your Name, Title / Dept. or Tribal Member

Additional Requestor:

Name, Title / Dept.

Additional Requestor:

Name, Title / Dept.

Oneida Business Committee Agenda Request

6. Cover Memo:

Describe the purpose, background/history, and action requested:

Oneida Library Quarterly Report for Jan. Feb. March 2017

1) Save a copy of this form for your records.

2) Print this form as a *.pdf *OR* print and scan this form in as *.pdf.

3) E-mail this form and all supporting materials in a **SINGLE** *.pdf file to: BC_Agenda_Requests@oneidanation.org

**ONEIDA COMMUNITY LIBRARY BOARD
QUARTERLY REPORT January-March 2017**

MISSION STATEMENT: Provide for the informational needs of the Oneida Community while building a collection that reflects our unique Oneida heritage. All persons will have access to current, balanced materials, services and programs that will enrich their information, cultural and recreational needs.

NAME OF BOARD: Oneida Community Library Board

CONTACT: Dylan Benton, Chair

MEMBERS: Bridget John ,Vice Chair
Dr. Carol Cornelius, Secretary
Roxanne Anderson, Member
Jennifer Hill, Member

BC LIAISON: Fawn Billie

MINUTES:

The following meeting minutes have been approved by the Oneida Community Library Board and sent to Kathy Metoxen and Fawn Billie:

January 18, 2017, Feb. 8, 2017 March 8, 2017

ACTION TAKEN:

The Board meets at the Library, the second Wednesday of the month at 4:30 p.m.

HIGHLIGHTS OF THE LIBRARY

January 2017

*Several libraries in the OWLSNET system are trying to connect libraries and Elder services. Oneida Elderly and Oneida Library are researching a partnership to make a mobile library connection. There is a quarterly meeting in Appleton that is attended. This project a program that will enable Elders to order their selections on-line.

* Green Earth continues to introduce Code.org for the young people who did an hour of coding at the library.

*Patron count: 2,982

February 2017

*Nicolet Library Federation offers a series of Web conference topics which the staff can view live or later the taped version. The topic included: Planning & Evaluating Programs and Services for Youth, Staying Well, Library safety and dealing with challenging patrons.

*Green Earth is having a "Library After Hour Events" to focus on families using the library.

*Events: Mid-Winter Story Telling and Puppet Show included a presentation by Corina Williams from Cultural Heritage on Archival/Preservation work with 38 people attending. Cookies and Canvas, Library Lovers/ Luau, Dragons Love Tacos Event with stories, science technology, engineering and math hands on activities, Elder Day Bingo, Beading Circle, Monthly Maker Space, STEM activities and Hooray for Pre K.

*Bridget John motion to approve, Jennifer Hill seconded. Carried

*Patron Count 3,304

March 2017

*Library Lover's Luau event was a success with 30 participants. Available activities at the event- Bookmark contest, card making, coloring for stress relief and self-guided stations for all ages. Blind Date with a movie was introduced where a new release is wrapped I paper so patron didn't know what

movie they were getting. Patrons enjoyed free popcorn with checkout. Materials provided by grants from the Institute of Museum and Library Services.

* Dragons Love Tacos Event @ Green Earth had story time, walking taco's, STEM tables and Dragon Crafts

*Patron count – 3438

FINANCIAL:

All library budgets have a positive variance.

The Library will continue to apply for grants and will follow purchasing guidelines to stay within the budget.

The Library is taking great care to abide by cost containment guidelines.

SPECIAL EVENTS AND TRAVEL:

Reference Highlights of the Library above.

UPCOMING EVENTS

Planning a series of workshops on: 1) climate change with the Environmental department; 2) Longhouse, Tradition, History and Protocol, and, 3) Elder interview tapes.

Discussion on the need for more space at the Library.

PERSONAL COMMENTS:

The Library Board would like to acknowledge the dedicated staff at the Library who continue to increase their knowledge and skills by taking classes and attending workshops and conferences.

The Board would like to commend the Library Staff for the valuable services they provide to the community.

The Oneida Library provides a safe, welcoming, and positive place for our young people and the community.

The Oneida Library provides a hub of activities for families and the community.

The Oneida Library is in dire need of more space. DPW safety report cited the need for space. The Library has now had to utilize an off site storage space at the Norbert Hill building. Several areas of need are space where rare books can be kept and accessed, and space for researchers.

Oneida Business Committee Agenda Request

1. Meeting Date Requested: 04 / 27 / 17

2. General Information:

Session: Open Executive - See instructions for the applicable laws, then choose one:

Agenda Header:

Accept as Information only

Action - please describe:

Oneida Personnel Commission 2017-2nd Quarter Report

3. Supporting Materials

Report Resolution Contract

Other:

1.

3.

2.

4.

Business Committee signature required

4. Budget Information

Budgeted - Tribal Contribution

Budgeted - Grant Funded

Unbudgeted

5. Submission

Authorized Sponsor / Liaison:

Primary Requestor/Submitter: Yvonne Jourdan, Chairperson, Oneida Personnel Commission
Your Name, Title / Dept. or Tribal Member

Additional Requestor: _____
Name, Title / Dept.

Additional Requestor: _____
Name, Title / Dept.

Oneida Business Committee Agenda Request

6. Cover Memo:

Describe the purpose, background/history, and action requested:

Oneida Personnel Commission, 2017-2nd Quarter Report

- 1) Save a copy of this form for your records.
- 2) Print this form as a *.pdf *OR* print and scan this form in as *.pdf.
- 3) E-mail this form and all supporting materials in a **SINGLE** *.pdf file to: BC_Agenda_Requests@oneidanation.org

ONEIDA PERSONNEL COMMISSION
 FY 2017- Quarterly Report Second Quarter
 January, February and March 2017
 Submitted by: Yvonne Jourdan

NAMES

Officers: Yvonne Jourdan, Chairperson
 Gary Smith, Vice-Chairperson
 Sharon Alvarez, Treasurer
 Tomas Escamea, Secretary

Members: Bradley Graham
 Richard Elm-Hill
 Jennifer Hill
 Leland Wigg-Ninham
 Eric Krawczyk
 Pearl Webster
 Carol Smith

MINUTES

All approved minutes have been submitted to the Office of the Tribal Secretary.

January 26, 2017	Regular Meeting	(Approved)
February 21, 2017	Regular Meeting	(Approved)
March 2, 2017	Special Meeting	(Approved)
March 9, 2017	Special Meeting	(Approved)
March 21, 2017	Regular Meeting	(Approved)

FINANCIAL

See attached R&E statements for the months of January, February and March 2017.

SPECIAL EVENTS AND TRAVEL

No out-of-state travel/training occurred during this quarter.

LOCAL TRAINING

Training for the first quarter of this fiscal year included standard initial reviews, grievance hearings, and grievance decisions training which took place in January, February and March 2017.

ACTIVITY REPORT-Oneida Personnel Commission

Activity	January	February	March	Totals
Pre-Screens	21	13	17	51
Interviews	5	14	7	26
Reassignments	6	5	8	19
Initial Reviews	2	2	4	8
Grievances	1	1	2	4

Deliberations	1	0	1	2
Decision Writing	1	1	0	2
Motion Decisions	0	1	1	2
Regular Meetings	1	1	1	3
Special Meetings	1	1	2	4
Training*	2	2	1	5
Non-Gaming Employees with an advocate	0	0	0	0
Non-Gaming Employees without an advocate	0	1	1	2
Gaming Employees with an advocate	0	0	1	1
Gaming Employees without an advocate	0	0	0	0
Non-Gaming Management with an advocate	0	0	0	0
Non-Gaming Management without an advocate	0	1	0	1
Gaming Management with an advocate	0	0	1	1
Gaming Management without an advocate	0	0	0	0

- The numbers within the Reassignment boxes, are the numbers of employees that were reassigned into different positions for that specific month.

Training could mean attending out-of-state, local training, or in-house training. New commissioners are mentored by existing commissioners during Initial Reviews, Grievance Hearings, Decision Writing, Hearing Officer Responsibilities, and Motion Decisions. This type of involvement is also considered training.

GOALS AND OBJECTIVES – FY2017

- | | |
|----------------------------------------------|--------------------------|
| 1. Personnel Commission By-Laws | REVISIONS |
| 2. Training Manual | IN PROGRESS |
| 3. Updating Qualifications for Commissioners | REVISIONS PENDING AT LOC |
| 3. Interdepartmental Relationships | NEEDS IMPROVEMENT |
| 4. Updating Personnel Commission SOP's | IN PROGRESS |

OBJECTIVE STATEMENT – FY 2017

1. Optimize organizational efficiency and effectiveness

2. Learning and growth perspective
3. Owner/customer/stakeholder perspective

MEETING REQUIREMENTS

Oneida Personnel Commission By-Laws, Article III. Meetings.

3-1 *Regular Meetings*. The OPC officers shall establish a schedule of regular meetings for the upcoming year beginning in November. Notice of meeting location, agenda and materials shall be forwarded by the Chairperson with the assistance of the Administrator. Robert's Rules of Order shall be used as a guideline for conducting meetings.

3-2 *Special Meetings*. Special meetings shall be called not less than three (3) days prior to the date of the special meeting.

3-3. *Emergency meetings*. Emergency meetings shall be scheduled as needed and provide details of the emergency.

3-4 *Legislative Sessions*. When considering revisions or suggestions to the OPC regarding the labor laws of the Tribe, a Legislative Session may be scheduled to devote a focused exclusive convened working meeting of the OPC to specifically address amendment or revision of existing or proposed labor laws of the Tribe. An internal OPC SOP may be drafted governing the procedures to be followed in implementing such Legislative Session.

3-5 *Quorum*. A quorum shall consist of a majority of the OPC members. In the absence of the Chairperson and the Vice-Chairperson, the members present at the meeting shall elect a Chairperson *Pro Tem* to preside over the meeting.

FOLLOW-UP

- Meeting with the Personnel Commission's alternate Liaison, David Jordan, Tribal Councilman, regarding issues and concerns of the Commission.

ONEIDA PERSONNEL COMMISSION REGULAR MEETING

January 26, 2017 – NOON
 East Wing Conference Room

Mission Statement: To develop an employment system that is orderly and fair and one that will benefit the individual worker and strengthen Tribal Programs and Tribal Government.

Secretary:

A. Call to Order: Attendance (12:00p.m.) Gate Keeper: Yvonne Jordan, Chairwoman, called the meeting to order at 12:02p.m.

Yvonne Jourdan	Chairwoman
Gary Smith	Vice-Chair
Sharon Alvarez	Treasurer
Carol Smith	Member
Tomas Escamea	Member
Bradley Graham	Member
Pearl Webster	Member
Jennifer Hill	Member
Eric Krawczyk	Member

Also Present:

Bridget Cornelius	Executive Assistant
Robert Sweeney	OPC Attorney
David Jordan	OBC Councilman
William Graham	Community Member

EXCUSED:

Eric Krawczyk	Member
---------------	--------

UNEXCUSED:

Leland Wigg-Ninham	Member
--------------------	--------

MOTION: Gary Smith motioned to approve the attendance excusing Eric Krawczyk

SECOND: Sharon Alvarez seconded the motion.

MOTION CARRIED UNANIMOUSLY

B. Approval of Agenda (5 minutes)

MOTION: Pearl Webster motioned to approve the agenda with changes:

SECOND: Bradley Graham seconded the motion.

MOTION CARRIED UNANIMOUSLY

ONEIDA PERSONNEL COMMISSION REGULAR MEETING
January 26, 2017 – NOON
East Wing Conference Room

C. Review\Approval of Minutes: December 20, 2016- OPC Regular Meeting

MOTION: Carol Smith motioned to approve the December 20, 2016, OPC Regular Meeting Minutes.

SECOND: Pearl Webster seconded the motion.

MOTION CARRIED UNANIMOUSLY

D. Tabled Business (none)

E. Old Business (4)

1. Draft article for the Kahliwisaks

Article will be in Kahliwisaks January 26, 2017

2. Internal Audit Request-UPDATE

No Update

3. Employment Law Draft 21-UPDATE

Update from Bob Sweeney more meetings schedule

4. Status of Complaint regarding the Area Manager of Fitness, Parks and Recreation-Update

MOTION: Bradley Graham to accept update

SECOND: Sharon Alvarez

MOTION CARRIED UNANIMOUSLY

F. New Business(3)

1. Scheduling Initial Reviews, Grievances, Reassignments and Housekeeping-(Gina Buenrostro 10 minutes)

MOTION: Tomas Escamea moved to go into executive session

SECOND: Sharon Alvarez

TIME: 12:25PM

MOTION CARRIED UNANIMOUSLY

MOTION: Bradley Graham moved to come out of executive session

SECOND: Pearl Webster

TIME: 12:30PM

a. 2017-1st quarterly Report-Approval

MOTION: Gary Smith moved to approve quarterly report.

SECOND: pearl Webster

MOTION CARRIED UNANIMOUSLY

b. Request to have training waived-Leland Wigg-Ninham

MOTION: Bradley Graham move to deny

SECOND: Gary Smith

Upsets: carol Smith

c. Vacation request-Gary Smith

ONEIDA PERSONNEL COMMISSION REGULAR MEETING
January 26, 2017 – NOON
East Wing Conference Room

MOTION Sharon Alvarez to accept vacation request
SECOND: Bradley Graham
MOTION CARRIED UNANIMOUSLY

d. Officer Election:

Elections are in March

e. Space issues:

FYI

f. Prescreen and Interviews-OPC

Discussion regarding adhering to the policy and procedure in the blue book

g. Commission vacancies

Vacancies were put in the Kahliwisaks

h. Commission update ¼ report

Bradley wanted to send report to Kahliwisaks

2. Financial Report January 2016 (entire commission 10 minutes)

MOTION: Gary Smith approved the report

SECOND: Bradley Graham

MOTION CARRIED 1 upstencion

3. Activity Report January 2017

MOTION: Carol Smith approved the report

SECOND: Gary Smith

MOTION CARRIED UNANIMOUSLY

MOTION: Bradley Graham moved to adjourn.

SECOND: Sharon Alveraz

MOTION CARRIED UNANIMOUSLY

TIME: 1:55pm

Minutes taken for the secretary by Tomas Escamea

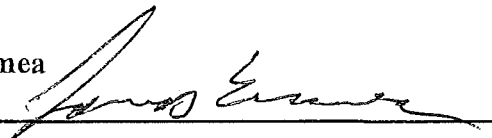

ONEIDA PERSONNEL COMMISSION REGULAR MEETING
 FEBRUARY 21, 2017 – NOON
 East Wing Conference Room

Mission Statement: To develop an employment system that is orderly and fair and one that will benefit the individual worker and strengthen Tribal Programs and Tribal Government.

Secretary:

- A. Call to Order: Attendance (12:00p.m.) Gate Keeper: Yvonne Jordan, Chairwoman, called the meeting to order at 12:01p.m.

Yvonne Jourdan	Chairwoman
Carol Smith	Member
Bradley Graham	Member
Pearl Webster	Member
Jennifer Hill	Member
Eric Krawczyk	Member
Sharon Alvarez	Treasurer
Tomas Escamea	Member

Also Present:

Bridget Cornelius	Executive Assistant
Robert Sweeney	OPC Attorney
Gina Buenrostro	Administrator

EXCUSED:

Richard Hill	Member
Gary Smith	Vice Chair

UNEXCUSED:

Leland Wigg-Ninham	Member
--------------------	--------

MOTION: Pearl Webster motioned to approve the attendance un-excusing Leland Wigg-Ninham and excusing Richard Hill.

SECOND: Bradley Graham

OPPOSED: Eric Krawczyk

ABSTAINED: Carol Smith

MOTION CARRIED

- B. Approval of Agenda (5 minutes)

MOTION: Bradley Graham motioned to approve the agenda with changes.

SECOND: Pearl Webster seconded the motion.

MOTION CARRIED UNANIMOUSLY

ONEIDA PERSONNEL COMMISSION REGULAR MEETING
 FEBRUARY 21, 2017 – NOON
 East Wing Conference Room

C. Review\Approval of Minutes: January 26, 2017-Regular

MOTION: Eric Krawczyk approved minutes with corrections.

SECOND: Pearl Webster

MOTION CARRIED UNANIMOUSLY

MOTION: Pearl Webster moved to go into executive session.

SECOND: Carol Smith

OPPOSED: Bradley Graham

MOTION CARRIED

Time:12:14pm

MOTION: Bradley Graham moved to come out of executive session.

SECOND: Eric Krawczyk

MOTION CARRIED UNANIMOUSLY Time: 1:01pm

D. Tabled Business: NONE

E. Old Business: (4)

1. Draft Article for the Kahliwisaks
FYI-Special Meeting scheduled for March 2, 2017

2. Internal Audit Request Update
No update

3. Employment Law-Draft 22
Special Meeting scheduled for March 2, 2017

4. Status of Complaint regarding Area Manager

MOTION: Pearl Webster moved to go into executive session.

SECOND: Bradley Graham

MOTION CARRIED UNANIMOUSLY Time: 1:14pm

MOTION: Sharon Alvarez to come out of executive session.

SECOND: Pearl Webster

MOTION CARRIED UNANIMOUSLY Time: 1:47pm

F. New Business: (3)

1. Scheduling Initial Reviews, Grievances, Reassignments and Housekeeping
 - a. Participation of OPC Members (Chair will send a letter to Commission Wigg-Ninham)
 - b. OPC officer elections (Will be placed on hold until outcome of Employment Law)

ONEIDA PERSONNEL COMMISSION REGULAR MEETING

FEBRUARY 21, 2017 – NOON

East Wing Conference Room

- c. Status of vacancies (updated)
- d. Correspondence to the OBC (updated Commission will report again in next meeting)
- e. OPC concerns regarding criminal background checks on OPC members (this was addressed in the beginning of meeting and will be moved to the March 2, 2017-Special meeting)
- f. Sharon Alvarez requesting medical leave (Approved March 6-2017 to April 3-2017)

MOTION: Bradley Graham moved to approve.

SECOND: Jennifer Hill

MOTION CARRIED UNANIMOUSLY

- g. Revision of First Quarterly Report (this item will be moved to the March regular meeting)
- h. Schedule Special Meeting

MOTION: Eric Krawczyk to move Special Meeting to March 2, 2017.

SECOND: Bradley Graham

MOTION CARRIED UNANIMOUSLY

2. Financial Report December 2016 (entire commission)

MOTION: Eric Krawczyk moved to approve.

SECOND: Bradley Graham

MOTION CARRIED UNANIMOUSLY

3. Activity Report January 2017

MOTION: Carol Smith moved to approve.

SECOND: Sharon Alvarez

MOTION CARRIED UNANIMOUSLY

MOTION: Bradley Graham moved to adjourn.

SECOND: Pearl Webster

MOTION CARRIED UNANIMOUSLY

TIME: 2:08pm

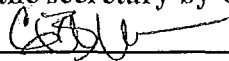
Minutes taken for the secretary by Gina Buenrostro

ONEIDA PERSONNEL COMMISSION SPECIAL MEETING

March 2, 2017 – NOON

East Wing Conference Room

Mission Statement: To develop an employment system that is orderly and fair and one that will benefit the individual worker and strengthen Tribal Programs and Tribal Government.

Secretary:

- A. Call to Order: Attendance (12:00p.m.) Gate Keeper: Yvonne Jordan, Chairwoman, called the meeting to order at 12:00p.m.

Yvonne Jourdan	Chairwoman
Sharon Alvarez	Treasurer
Carol Smith	Member
Leland Wigg-Ninham	Member
Bradley Graham	Member
Pearl Webster	Member
Jennifer Hill	Member
Eric Krawczyk	Member

Also Present:

Bridget Cornelius	Executive Assistant
Robert Sweeney	OPC Attorney
Gina Buenrostro	Administrator

EXCUSED:

Gary Smith	Member
Richard Hill	Member

UNEXCUSED:

Tomas Escamea	Member
---------------	--------

MOTION: Pearl Webster motioned to approve the attendance excusing Gary Smith and Richard Hill.

SECOND: Sharon Alvarez seconded the motion.

MOTION CARRIED UNANIMOUSLY

- B. Approval of Agenda (5 minutes)

MOTION: Bradley Graham motioned to approve the agenda with changes:

SECOND: Eric Krawczyk seconded the motion.

MOTION CARRIED UNANIMOUSLY

ONEIDA PERSONNEL COMMISSION SPECIAL MEETING
March 2, 2017 – NOON
East Wing Conference Room

C. Review\Approval of Minutes: **NONE**

D. Tabled Business: **NONE**

E. Old Business: **NONE**

F. New Business: **(3)**

1. Employment Law

MOTION: Bradley Graham motioned to get approved article to the Kahliwisaks submitted by deadline, sent out postcard tribal wide regarding the perspective of the Personnel Commission pertaining to the Employment Law, and set up event to notify community of perspective of Personnel Commission.

SECOND: Sharon Alvarez

MOTION CARRIED UNANIMOUSLY

2. Commissioner Background Issue

MOTION: Leland Wigg-Ninham to go into executive session at 12:54 PM

SECOND: Bradley Graham

MOTION CARRIED UNANIMOUSLY

MOTION: Pearl Webster to come out of executive session at 1:17PM

MOTION CARRIED UNANIMOUSLY

MOTION: Pearl Webster moved to table this item to the next meeting.

SECOND: Sharon Alvarez

OPPOSED: Carol Smith and Leland Wigg-Ninham

MOTION CARRIED

3. Participation of Commissioner Wigg-Ninham

MOTION: Pearl Webster moved to table this item to the next meeting.

SECOND: Sharon Alvarez

OPPOSED: Carol Smith and Leland Wigg-Ninham

MOTION CARRIED

MOTION: Bradley Graham moved to adjourn.

SECOND: Leland Wigg-Ninham

MOTION CARRIED UNANIMOUSLY

ONEIDA PERSONNEL COMMISSION SPECIAL MEETING
March 2, 2017 – NOON
East Wing Conference Room

TIME: 1:20pm

Minutes taken for the secretary by Gina Buenrostro

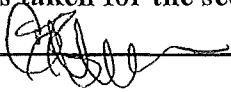

ONEIDA PERSONNEL COMMISSION SPECIAL MEETING

March 9, 2017 – NOON

East Wing Conference Room

Mission Statement: To develop an employment system that is orderly and fair and one that will benefit the individual worker and strengthen Tribal Programs and Tribal Government.

Secretary:

A. Call to Order: Attendance (12:00p.m.) Gate Keeper: Yvonne Jordan, Chairwoman, called the meeting to order at 12:00p.m.

Yvonne Jourdan	Chairwoman
Gary Smith	Vice-Chair
Carol Smith	Member
Leland Wigg-Ninham	Member
Bradley Graham	Member
Pearl Webster	Member
Jennifer Hill	Member
Eric Krawczyk	Member

Also Present:

Bridget Cornelius	Executive Assistant
Robert Sweeney	OPC Attorney
Gina Buenrostro	Administrator

EXCUSED:

Richard Hill	Member
--------------	--------

UNEXCUSED:

Eric Krawczyk	Member
---------------	--------

MOTION: Bradley Graham motioned to approve the attendance excusing Richard Hill and un-excusing Eric Krawczyk

SECOND: Jennifer Hill seconded the motion.

MOTION CARRIED UNANIMOUSLY

B. Approval of Agenda (5 minutes)

MOTION: Pearl Webster motioned to approve the agenda with changes:

SECOND: Bradley Graham seconded the motion.

MOTION CARRIED UNANIMOUSLY

ONEIDA PERSONNEL COMMISSION SPECIAL MEETING
March 9, 2017 – NOON
East Wing Conference Room

C. Review\Approval of Minutes: NONE

D. Tabled Business: NONE

E. Old Business: NONE

F. New Business: (3)

1. Employment Law

MOTION: Bradley Graham motioned to approve revised article and submit immediately to the Kahliwisaks

SECOND: Tomas Escamea

OPPOSED: Leland Wigg-Ninham

MOTION CARRIED UNANIMOUSLY

2. Commissioner Background Issue

3. Participation of Commissioner Wigg-Ninham

MOTION: Pearl Webster moved to table this item to the next meeting.

SECOND: Sharon Alvarez

OPPOSED: Carol Smith and Leland Wigg-Ninham

MOTION CARRIED

MOTION: Bradley Graham moved to adjourn.

SECOND: Leland Wigg-Ninham

MOTION CARRIED UNANIMOUSLY

TIME: 1:20pm

Minutes taken for the secretary by Gina Buenrostro

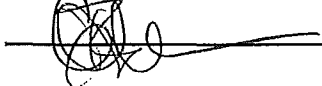

ONEIDA PERSONNEL COMMISSION REGULAR MEETING
MARCH 21, 2017 – NOON
East Wing Conference Room

Mission Statement: To develop an employment system that is orderly and fair and one that will benefit the individual worker and strengthen Tribal Programs and Tribal Government.

Secretary:

- A. Call to Order: Attendance (12:00p.m.) Gate Keeper: Yvonne Jordan, Chairwoman, called the meeting to order at 12:01p.m.

Yvonne Jourdan	Chairwoman
Carol Smith	Member
Bradley Graham	Member
Pearl Webster	Member
Eric Krawczyk	Member
Sharon Alvarez	Treasurer
Gary Smith	Vice Chair
Thomas Escamea	Secretary
Leland Wigg-Ninham	Member

Also Present:

Bridget Cornelius	Executive Assistant
Robert Sweeney	OPC Attorney

UNEXCUSED:

Richard Elm-Hill	Member
Jennifer Hill	Member

MOTION: Gary Smith moved to approve the attendance.

SECOND: Bradley Graham

MOTION CARRIED UNANIMOUSLY

- B. Approval of Agenda (5 minutes)

MOTION: Sharon Alvarez motioned to approve the agenda.

SECOND: Carol Smith

MOTION CARRIED UNANIMOUSLY

- C. Review\Approval of Minutes: February 21, 2017-Regular, March 2, 2017-Special, March 9, 2017-Special

MOTION: Bradley Graham moved to approve all the minutes.

SECOND: Pearl Webster

MOTION CARRIED UNANIMOUSLY

- D. Tabled Business: NONE

ONEIDA PERSONNEL COMMISSION REGULAR MEETING
MARCH 21, 2017 – NOON
East Wing Conference Room

E. Old Business: (4)

1. Draft Article for the Kahliwisaks (Entire Commission)
No Update
2. Internal Audit Reequst Update (Entire Commission)
No Update
3. Employment Law, Draft 22 (Entire Commission)
No Update
4. Status of filing at the Judiciary: Area Manager, Fitness, Parks and Recreation-Update-(Entire Commission 10 minutes)

F. New Business: (3)

1. Scheduling Initial Reviews, Grievances, Reassignments and Housekeeping--(Gina Buenrostro 30 minutes)

MOTION: Bradley Graham moved to go into executive session.

SECOND: Gary Smith

MOTION CARRIED UNANIMOUSLY

Time: 1:00pm

- a. Cell Phone use during OPC activities
- b. Update and status of OPC terms
- c. Update in purchase referred supervisor position
- d. Follow up of GTC meeting regarding the Employment Law
- e. Update and Revise 1st Quarterly Report for 2017
- f. Update-Thomas Escamea

MOTION: Bradley Graham moved to come out of executive session.

SECOND: Gary Smith

MOTION CARRIED UNANIMOUSLY

Time: 1:50pm

2. Financial Report January 2017 (Entire Commission)

MOTION: Eric Krawczyk move to have accept Financial Report.

SECOND: Carol Smith

MOTION CARRIED UNANIMOUSLY

3. Activity Report- February 2017 (Entire Commission)

MOTION: Carol Smith moves to approve.

SECOND: Pearl Webster

MOTION CARRIED UNANIMOUSLY

MOTION: Eric Krawczyk moves to adjourn.

ONEIDA PERSONNEL COMMISSION REGULAR MEETING
MARCH 21, 2017 – NOON
East Wing Conference Room

SECOND: Sharon Alvarez
Time: 1:58pm

Minutes taken for the secretary by Gina Buenrostro

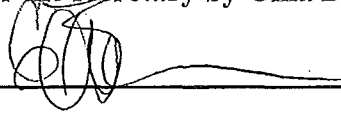

4273007 - PERSONNEL BOARD
 STATEMENTS PRODUCED PRIOR TO PERIOD CLOSING DATES ARE SUBJECT TO CHANGE
 REPORT RUNDATE/RUNTIME: 2/14/2017 08:09:16

CBRUNE01
 04JAN/2017

REPORT NAME: BD_T_FISCL
 REF:C

4273007 - PERSONNEL BOARD
 REPORT FOR COMPLETE FISCAL YEAR
 AND Y-T-D INFORMATION

Year To Date figures
 as of JAN 2017

Processing Instruction: Submit for last closed month.

ACCOUNT NAME	ACCOUNT NUMBER	FISCAL 2015 ACTUAL	FISCAL 2016 ACTUAL	Y-T-D 2017 ACTUAL	Y-T-D 2017 BUDGET	ANNUAL 2017 BUDGET	ANNUAL 2017 PROJECTED	ANNUAL 2018 PROPOSED BUDGET
Revenue - External								
SERVICE FEE REVENUE	000-400001-000	90	40	52			52	
Sub-Total		90	40	52			52	
Revenue/Contribution- Internal								
I/T SERVICE FEE REVENUE	000-450001-000	30						
TRIBAL CONTRIBUTION	000-458100-000	248,510	276,555	96,192	110,711	332,135	317,616	342,615
INTRA/SAME SERVICE FEE REVENUE	000-480001-000	30						
Sub-Total		248,570	276,555	96,192	110,711	332,135	317,616	342,615
Labor/Payroll Expense								
PERSONNEL	000-502100-000	74,757	78,004	26,768	30,427	91,275	87,616	91,275
WAGE ACCRUAL EXPENSE	000-502100-999	334	771	(1,032)			(1,032)	
SALARIES - TRAINING	000-502110-000	36		28			28	
OVERTIME	000-503100-000			31			31	
PAID TIME OFF	000-504000-000	12,067	13,007	6,243			6,243	
FRINGE BENEFIT	000-505000-000	35,738	37,753	13,670	12,569	37,697	38,798	37,697
FRINGE ACCRUAL EXPENSE	000-505000-999	160	313	(405)			(405)	
Sub-Total		123,092	129,848	45,303	42,996	128,972	131,279	128,972
Cost of Sales								
Sub-Total								
External Expenses								
SUPPLIES & MATERIALS	000-700001-000	1,324	1,006	649	120	360	889	840
COPY CHARGES	000-700010-000	1,027	951	277	138	410	549	410
TRANSP. & PER DIEM	000-701000-000				664	2,000	1,336	2,000
OUTSIDE SERVICES	000-702010-000	527	208	16,291	256	760	16,795	760
LEGAL SERVICES	000-702400-000	14,903	50,558		14,000	42,000	28,000	42,000
TRAINING & EDUCATION	000-705010-000				664	2,000	1,336	2,000
RENTAL USAGE	000-705202-000	1,561	1,543	514	382	1,150	1,282	1,150
HEAT & LIGHTS	000-705211-000	3,721	3,291	1,131	1,500	4,500	4,131	4,500
WATER & SEWER	000-705212-000	91	88	35	20	60	75	60
TELEPHONE	000-705213-000	432	455	119	142	430	407	430
BUSINESS EXPENSE	000-705300-000				64	200	136	200
STIPENDS	000-705305-000							

4273007 - PERSONNEL BOARD
 STATEMENTS PRODUCED PRIOR TO PERIOD CLOSING DATES ARE SUBJECT TO CHANGE
 REPORT RUNDATE/RUNTIME: 2/14/2017 08:09:16

CBRUNE01
 04JAN/2017

REPORT NAME: BD_T_FISCL
 REF:C

4273007 - PERSONNEL BOARD
 REPORT FOR COMPLETE FISCAL YEAR
 AND Y-T-D INFORMATION

Year To Date figures
 as of JAN 2017

Processing Instruction: Submit for last closed month.

ACCOUNT NAME	ACCOUNT NUMBER	FISCAL 2015 ACTUAL	FISCAL 2016 ACTUAL	Y-T-D 2017 ACTUAL	Y-T-D 2017 BUDGET	ANNUAL 2017 BUDGET	ANNUAL 2017 PROJECTED	ANNUAL 2018 PROPOSED BUDGET
INSURANCE	000-705500-000	619	569	189	220	660	629	660
STIPENDS	100-705305-000	37,000	24,500	10,375	26,918	80,750	64,207	85,750
STIPENDS	200-705305-000		1,200	350			350	5,000
STIPENDS	400-705305-000	6,300	5,850	1,700	2,764	8,300	7,236	8,300
STIPENDS	500-705305-000	32,250	33,300	11,650	11,596	34,780	34,834	34,780
STIPENDS	600-705305-000	7,575	5,200	1,250	2,200	6,600	5,650	6,600
Sub-Total		107,330	128,719	44,530	61,648	184,960	167,842	195,440
Internal Expenses								
I/T SUPPLIES & MATERIALS	000-750001-000	75			36	100	64	100
I/T - PRINTING	000-750009-000				36	100	64	100
I/T RENT EXPENSE	000-755201-000	3,442			1,164	3,500	2,336	3,500
I/T UTILITIES EXPENSE	000-755210-000	1	1					
I/T DEPRECIATION ALLOCATION	000-755216-000		3,442	1,147			1,147	
INDIRECT COSTS	000-758300-000	14,662	14,462	5,423	4,831	14,503	15,095	14,503
INDIRECT COST ACCRUAL EXPENSE	000-758300-999	56	122	(160)			(160)	
Sub-Total		18,236	18,027	6,410	6,067	18,203	18,546	18,203
NET PROFIT OR (LOSS)		2	1	1			1	

4273007 - PERSONNEL BOARD
 STATEMENTS PRODUCED PRIOR TO PERIOD CLOSING DATES ARE SUBJECT TO CHANGE
 REPORT RUNDATE/RUNTIME: 3/13/2017 16:23:34

CBRUNE01
 05FEB/2017

REPORT NAME: BD_T_FISCL
 REF:C
 4273007 - PERSONNEL BOARD
 REPORT FOR COMPLETE FISCAL YEAR
 AND Y-T-D INFORMATION

Processing Instruction: Submit for last closed month.
 Year To Date figures
 as of FEB 2017

ACCOUNT NAME	ACCOUNT NUMBER	FISCAL 2015 ACTUAL	FISCAL 2016 ACTUAL	Y-T-D 2017 ACTUAL	Y-T-D 2017 BUDGET	ANNUAL 2017 BUDGET	ANNUAL 2017 PROJECTED	ANNUAL 2018 PROPOSED BUDGET
Revenue - External								
SERVICE FEE REVENUE	000-400001-000	90	40	52			52	
Sub-Total		90	40	52			52	
Revenue/Contribution- Internal								
I/T SERVICE FEE REVENUE	000-450001-000	30						
TRIBAL CONTRIBUTION	000-458100-000	248,510	276,555	125,720	138,389	332,135	319,466	342,615
INTRA/SAME SERVICE FEE REVENUE	000-480001-000	30		10			10	
Sub-Total		248,570	276,555	125,730	138,389	332,135	319,476	342,615
Labor/Payroll Expense								
PERSONNEL	000-502100-000	74,757	78,004	34,505	38,033	91,275	87,747	91,275
WAGE ACCRUAL EXPENSE	000-502100-999	334	771	(854)			(854)	
SALARIES - TRAINING	000-502110-000	36		28			28	
OVERTIME	000-503100-000			44			44	
PAID TIME OFF	000-504000-000	12,067	13,007	7,507			7,507	
FRINGE BENEFIT	000-505000-000	35,738	37,753	17,155	15,710	37,697	39,142	37,697
FRINGE ACCRUAL EXPENSE	000-505000-999	160	313	(383)			(383)	
Sub-Total		123,092	129,848	58,002	53,743	128,972	133,231	128,972
Cost of Sales								
Sub-Total								
External Expenses								
SUPPLIES & MATERIALS	000-700001-000	1,324	1,006	649	150	360	859	840
COPY CHARGES	000-700010-000	1,027	951	277	172	410	515	410
TRANSP. & PER DIEM	000-701000-000				831	2,000	1,169	2,000
OUTSIDE SERVICES	000-702010-000	527	208	25,691	319	760	26,132	760
LEGAL SERVICES	000-702400-000	14,903	50,558		17,500	42,000	24,500	42,000
TRAINING & EDUCATION	000-705010-000				831	2,000	1,169	2,000
RENTAL USAGE	000-705202-000	1,561	1,543	643	478	1,150	1,315	1,150
HEAT & LIGHTS	000-705211-000	3,721	3,291	1,538	1,875	4,500	4,163	4,500
WATER & SEWER	000-705212-000	91	88	46	25	60	81	60
TELEPHONE	000-705213-000	432	455	119	178	430	371	430
BUSINESS EXPENSE	000-705300-000				81	200	119	200
STIPENDS	000-705305-000							

4273007 - PERSONNEL BOARD
 STATEMENTS PRODUCED PRIOR TO PERIOD CLOSING DATES ARE SUBJECT TO CHANGE
 REPORT RUNDATE/RUNTIME: 3/13/2017 16:23:34

CBRUNE01
 05FEB/2017

REPORT NAME: BD_T_FISCL REF:C
 REPORT FOR COMPLETE FISCAL YEAR
 AND Y-T-D INFORMATION

Year To Date figures
 as of FEB 2017

Processing Instruction: Submit for last closed month.

ACCOUNT NAME	ACCOUNT NUMBER	FISCAL 2015 ACTUAL	FISCAL 2016 ACTUAL	Y-T-D 2017 ACTUAL	Y-T-D 2017 BUDGET	ANNUAL 2017 BUDGET	ANNUAL 2017 PROJECTED	ANNUAL 2018 PROPOSED BUDGET
INSURANCE	000-705500-000	619	569	237	275	660	622	660
STIPENDS	100-705305-000	37,000	24,500	12,125	33,647	80,750	59,228	85,750
STIPENDS	200-705305-000		1,200	350			350	5,000
STIPENDS	400-705305-000	6,300	5,850	2,050	3,456	8,300	6,894	8,300
STIPENDS	500-705305-000	32,250	33,300	14,500	14,494	34,780	34,786	34,780
STIPENDS	600-705305-000	7,575	5,200	1,350	2,750	6,600	5,200	6,600
Sub-Total		107,330	128,719	59,575	77,062	184,960	167,473	195,440
Internal Expenses								
I/T SUPPLIES & MATERIALS	000-750001-000	75			44	100	56	100
I/T - PRINTING	000-750009-000				44	100	56	100
I/T RENT EXPENSE	000-755201-000	3,442			1,456	3,500	2,044	3,500
I/T UTILITIES EXPENSE	000-755210-000	1	1					
I/T DEPRECIATION ALLOCATION	000-755216-000		3,442	1,434			1,434	
INDIRECT COSTS	000-758300-000	14,662	14,462	6,902	6,040	14,503	15,365	14,503
INDIRECT COST ACCRUAL EXPENSE	000-758300-999	56	122	(131)			(131)	
Sub-Total		18,236	18,027	8,205	7,584	18,203	18,824	18,203
NET PROFIT OR (LOSS)		2	1					

4273007 - PERSONNEL BOARD
 STATEMENTS PRODUCED PRIOR TO PERIOD CLOSING DATES ARE SUBJECT TO CHANGE
 REPORT RUNDATE/RUNTIME: 4/13/2017 15:49:58

CBRUNE01
 06MAR/2017

REPORT NAME: BD_T_FISCL REF:C
 REPORT FOR COMPLETE FISCAL YEAR
 AND Y-T-D INFORMATION

Processing Instruction: Submit for last closed month.

Year To Date figures
 as of MAR 2017

ACCOUNT NAME	ACCOUNT NUMBER	FISCAL 2015 ACTUAL	FISCAL 2016 ACTUAL	Y-T-D 2017 ACTUAL	Y-T-D 2017 BUDGET	ANNUAL 2017 BUDGET	ANNUAL 2017 PROJECTED	ANNUAL 2018 PROPOSED BUDGET
Revenue - External								
SERVICE FEE REVENUE	000-400001-000	90	40	52			52	
Sub-Total		90	40	52			52	
Revenue/Contribution- Internal								
I/T SERVICE FEE REVENUE	000-450001-000	30						
TRIBAL CONTRIBUTION	000-458100-000	248,510	276,555	156,958	166,067	332,135	323,026	342,615
INTRA/SAME SERVICE FEE REVENUE	000-480001-000	30		10			10	
Sub-Total		248,570	276,555	156,968	166,067	332,135	323,036	342,615
Labor/Payroll Expense								
PERSONNEL	000-502100-000	74,757	78,004	45,001	45,639	91,275	90,637	91,275
WAGE ACCRUAL EXPENSE	000-502100-999	334	771	940			940	
SALARIES - TRAINING	000-502110-000	36		28			28	
OVERTIME	000-503100-000			55			55	
PAID TIME OFF	000-504000-000	12,067	13,007	7,684			7,684	
FRINGE BENEFIT	000-505000-000	35,738	37,753	20,837	18,851	37,697	39,683	37,697
FRINGE ACCRUAL EXPENSE	000-505000-999	160	313	192			192	
Sub-Total		123,092	129,848	74,737	64,490	128,972	139,219	128,972
Cost of Sales								
Sub-Total								
External Expenses								
SUPPLIES & MATERIALS	000-700001-000	1,324	1,006	729	180	360	909	840
COPY CHARGES	000-700010-000	1,027	951	496	206	410	700	410
TRANSP. & PER DIEM	000-701000-000				998	2,000	1,002	2,000
OUTSIDE SERVICES	000-702010-000	527	208	30,723	382	760	31,101	760
LEGAL SERVICES	000-702400-000	14,903	50,558		21,000	42,000	21,000	42,000
TRAINING & EDUCATION	000-705010-000				998	2,000	1,002	2,000
RENTAL USAGE	000-705202-000	1,561	1,543	772	574	1,150	1,348	1,150
HEAT & LIGHTS	000-705211-000	3,721	3,291	1,883	2,250	4,500	4,133	4,500
WATER & SEWER	000-705212-000	91	88	54	30	60	84	60
TELEPHONE	000-705213-000	432	455	130	214	430	346	430
BUSINESS EXPENSE	000-705300-000				98	200	102	200
STIPENDS	000-705305-000							

4273007 - PERSONNEL BOARD
 STATEMENTS PRODUCED PRIOR TO PERIOD CLOSING DATES ARE SUBJECT TO CHANGE
 REPORT RUNDATE/RUNTIME: 4/13/2017 15:49:58

CBRUNE01
 06MAR/2017

4273007 - PERSONNEL BOARD
 REPORT NAME: BD_T_FISCL REPORT FOR COMPLETE FISCAL YEAR
 REF:C AND Y-T-D INFORMATION

Processing Instruction: Submit for last closed month. Year To Date figures as of MAR 2017

ACCOUNT NAME	ACCOUNT NUMBER	FISCAL 2015 ACTUAL	FISCAL 2016 ACTUAL	Y-T-D 2017 ACTUAL	Y-T-D 2017 BUDGET	ANNUAL 2017 BUDGET	ANNUAL 2017 PROJECTED	ANNUAL 2018 PROPOSED BUDGET
INSURANCE	000-705500-000	619	569	284	330	660	614	660
STIPENDS	100-705305-000	37,000	24,500	14,250	40,376	80,750	54,624	85,750
STIPENDS	200-705305-000		1,200	1,150			1,150	5,000
STIPENDS	400-705305-000	6,300	5,850	2,600	4,148	8,300	6,752	8,300
STIPENDS	500-705305-000	32,250	33,300	16,650	17,392	34,780	34,038	34,780
STIPENDS	600-705305-000	7,575	5,200	1,500	3,300	6,600	4,800	6,600
Sub-Total		107,330	128,719	71,221	92,476	184,960	163,705	195,440
Internal Expenses								
I/T SUPPLIES & MATERIALS	000-750001-000	75			52	100	48	100
I/T - PRINTING	000-750009-000			523	52	100	571	100
I/T RENT EXPENSE	000-755201-000	3,442			1,748	3,500	1,752	3,500
I/T UTILITIES EXPENSE	000-755210-000	1	1					
I/T DEPRECIATION ALLOCATION	000-755216-000		3,442	1,721			1,721	
INDIRECT COSTS	000-758300-000	14,662	14,462	8,654	7,249	14,503	15,908	14,503
INDIRECT COST ACCRUAL EXPENSE	000-758300-999	56	122	163			163	
Sub-Total		18,236	18,027	11,061	9,101	18,203	20,163	18,203
NET PROFIT OR (LOSS)		2	1	1			1	

Oneida Business Committee Agenda Request

1. Meeting Date Requested: 4 / 27 / 17

2. General Information:

Session: Open Executive - See instructions for the applicable laws, then choose one:

Agenda Header:

Accept as Information only

Action - please describe:

Requesting approval of Police Commissions 2nd Quarterly Report - January, February, March 2017

3. Supporting Materials

Report Resolution Contract

Other:

1.

3.

2.

4.

Business Committee signature required

4. Budget Information

Budgeted - Tribal Contribution Budgeted - Grant Funded Unbudgeted

5. Submission

Authorized Sponsor / Liaison:

Primary Requestor/Submitter:
Your Name, Title / Dept. or Tribal Member

Additional Requestor: _____
Name, Title / Dept.

Additional Requestor: _____
Name, Title / Dept.

Oneida Business Committee Agenda Request

6. Cover Memo:

Describe the purpose, background/history, and action requested:

Per the Comprehensive Policy on Boards, Committee, and Commissions needs to submit report.

- 1) Save a copy of this form for your records.
- 2) Print this form as a *.pdf *OR* print and scan this form in as *.pdf.
- 3) E-mail this form and all supporting materials in a **SINGLE** *.pdf file to: BC_Agenda_Requests@oneidanation.org

Oneida Nation
Oneida Police Commission
3759 W Mason St
Ridge view Plaza Suite 4
Oneida WI 54155



Vacant, President
Sandra Reveles, Vice President
Beverly Anderson, Secretary
Twylite Moore, Member
Lois Strong, Member

Lisa Summers, Liaison

Oneida Police Commission
2nd Quarterly Report - January, February, March 2017
Due April 18, 2017

CONTACT FOR REPORT

Sandra Reveles/Carol Silva

MINUTES

All approved meeting minutes are submitted to the Tribal Secretary's office quarterly from January, 2017 to March, 2017. Meetings are held the 4th (fourth) Wednesday of the month at 5:00PM at Ridge View Plaza, Suite 4. Meetings are open to the public except for Executive Session.

SPECIAL EVENTS/MEETINGS

- The Bylaws were approved on March 2002. The Police Commission has been working with HRD Mediator-Continuous Improvement employee on updating the Commissions Bylaws.
- Two New Commission members needs to be appointed by the Business Committee. Council members recommended to reevaluate one recommendation on 2-22-2017.
- Budget: As of February 2017 amount spent was \$29,412.98 The Commission remained in compliance with the budget constraints . At the time of submission of this report we have not received the March's Revenue and Expense amounts, therefore, the amount will be more.
- A Tribal Member that has been diagnosed with Cancer and the first thing on his "Bucket list" was to be a Police Officer. Chief Vanboxtel organized for Daniel Jourdan to be a Police Officer for a day and have him do a Ride Along. Officer Daniel was sworn in on March 21, 2017.
- Bernard Stevens-President resigned in February 2017. Presented Bernard with a Pendleton blanket and Eagle feather for his dedication and years of service on the Police Commission.

1. Staffing

The following is a list of positions that the Police Department is authorized and the amount that are staffed as of May.

<u>Position</u>	<u>Authorized</u>	<u>Staffed</u>	<u>Action</u>
Chief	1	1	
Assistant Chief	1	1	
Lieutenant	1	1	
Sergeant	3	3	
Detective/Sergeant	1	1	
Patrol Officer	12	11	
DARE Officer	1	1	
PSLO	1	1	
Community Resource Officer	1	1	
Office Manager	1	1	
Admin Assistant	1	1	
Dispatch Supervisor	1	1	
Dispatcher	5	4	Hiring Process
Gang Task Force Coordinator	<u>1</u>	<u>1</u>	
Total	31	29	

Patrol (Sergeants and Police Officers) and Dispatch (Dispatch Supervisor and Dispatcher) work a rotation of 5 days on, 3 days off. Shifts are 6a-2p, 2p-10p, and 10p to 6a. There are 2-3 officers per shift and 1-2 Dispatchers per shift.

Chief, Assistant Chief, Lieutenant, Detective Sergeant, DARE, PSLO, Office Manager, and Admin Assistant work normal business hours. Community Resource Officer and Gang Task Force Coordinator work normal business hours, but is available at different times due to programming in the community that may need to be attended.

2. BUDGET/GRANTS

FY 17 Budget - \$3,700, 456 (97% tribal contribution, 2.5% BIA funding, 0.5% grants)

YTD UNDERSPENT: \$ (40,768.00)

Tribal Contribution and overall expenses YTD underspent \$40,768.00

Payroll/Fringe benefits YTD underspent \$8,344.00

3. Grants-February

Submitted County Tribal Grant applications and are preparing the Coordinated Tribal Assistance Solicitation (CTAS).

4. Incident Type	Qtr 2 Jan - Mar 2016	Qtr 2 Jan - Mar 2017	% Change
CRIME PREVENTION	1623	1373	-15%
TRAFFIC STOP	782	626	-20%
BUILDING SECURITY	165	91	-45%
ASSIST	161	201	25%
MOTORIST ASSIST	153	142	-7%
ANIMAL	97	92	-5%
WELFARE CHECK	74	99	34%
MEDICAL	73	76	4%
TRAFFIC SAFETY INCIDENTS	58	129	122%
ACCIDENT	57	60	5%
SUSPICIOUS VEHICLE	55	56	2%
SUSPICIOUS SITUATION	44	38	-14%
ALARM	39	40	3%
MISCELLANEOUS	35	29	-17%
TRAFFIC HAZARD	33	24	-27%
RECKLESS DRIVING	32	23	-28%
DRUGS	30	37	23%
911 HANG UP	28	29	4%
THEFT	28	37	32%
JUVENILE COMPLAINTS	25	13	-48%
CIVIL MATTER	23	34	48%
PARKING COMPLAINT	23	2	-91%
WARRANT	22	34	55%
CIVIL PROCESS	22	30	36%
DISTURBANCE	21	38	81%
DOMESTIC DISTURBANCE	20	14	-30%
TRANSPORT	18	7	-61%

SUSPICIOUS PERSON	12	16	33%
LOST / FOUND	12	10	-17%
ALCOHOL	11	12	9%
ORDINANCE	12	8	-33%
TRESPASSING	11	7	-36%
RUNAWAY	9	7	-22%
SEX OFFENSE	7	5	-29%
DAMAGE TO PROPERTY	7	13	86%
FRAUD	7	6	-14%
BATTERY	7	3	-57%
DISORDERLY CONDUCT	6	1	-83%
HARASSMENT	6	9	50%
OPEN DOOR	6	3	-50%
TRUANCY	6	3	-50%
ABANDONED VEHICLE	5	5	0%
ACCIDENT WITH INJURY	4	1	-75%
AUTO THEFT	4	4	0%
NOISE COMPLAINT	4	1	-75%
WEAPON	4	2	-50%
EMERGENCY COMMITTAL	3	2	-33%
FIRE ALARM	3	3	0%
DEATH	3	2	-33%
911 ASSIST	3	6	100%
BURGLARY	2	1	-50%
FIRE CALL	2	7	250%
MISSING PERSON	2	1	-50%
CARBON MONOXIDE	1	5	400%
VIOLATION OF COURT ORDER	1	3	200%
RETAIL THEFT	0	4	400%
DISTURBANCE W/ A WEAPON	0	2	200%
COMPUTER CRIME	0	1	100%
FIREWORKS	0	1	100%
TOTAL	3901	3528	-11%

5. CUSTODIAL ARRESTS	Total	Alcohol Related	Drug Related	Gang Related
BROWN COUNTY Jan – March 17	121	38	51	0
Jan-March 16	164	61	34	0
OUTAGAMIE COUNTY Jan-March 17	52	12	13	0
Jan- March 16	66	19	15	0

Note: Some may be drug, alcohol and gang related arrests and these only show the number of arrests, but may be counted more than once.

6. TRAFFIC CITATIONS	This 1/4	Last 1/4
BROWN	123	111
OUTAGAMIE	21	27
TRIBAL CITATIONS	3	5

7. RESPONSE TIMES	This 1/4	Last 1/4
EMERGENCY	4:57	4:48
NON EMERGENCY	8:32	7:22

8. MUTUAL AID	This 1/4	Last 1/4
	201	161

All the sworn staff is deputized in Brown County – if a request is made for our Officers to respond off the Reservation, we are able to do so within Brown County. We are able to request Mutual Aid from other jurisdictions outside the reservation in time of need.

In Outagamie County, the Officers are deputized within the reservation boundaries – the Officers are not able to respond outside of the boundaries of the reservation. We are only able to request assistance from Outagamie County and if additional assistance is required, the Outagamie

County Sheriffs Department would have to make the request.

Since about 1985, Outagamie County Sheriff's Department has processed our citations – both Traffic and Ordinance Violations and sent them onto the courts. We have been notified that effective April 1, 2017, they will no longer be doing this for us, or for Freedom Police, as they have in the past. Freedom Police is similar to Oneida Police in that all their citations are adjudicated in County Circuit Court. We have someone trained to handle this part of the court process. It will add some responsibilities to our staff to provide the courts with the information needed, but we are unsure what that all entails as of now.

At the Business Committee meeting on December 14, 2016, Melinda Danforth made the following motion “that the Business Committee respectfully request the Chief of Police to do a follow-up letter to tribal members that live in Outagamie County regarding the jurisdiction of the Oneida Police Department and Outagamie County Sheriff's Department.” The Oneida Police Department has worked with Oneida Enrollments, Oneida GIS, Outagamie County Sheriff, Outagamie County GIS, and the Outagamie County Communications Center to accomplish this. A draft letter was sent to the Outagamie County Sheriff to review and is currently in the process of finalizing to have the letter sent out.

9. Activity/Training

Dispatcher Resigned during field training, the hiring process has begun to fill that position. One officer did not pass field training and was re-assigned to security. Officer Ralph Powless finished the field training process and is on patrol.

10. Oneida Gang Task Force Coordinator

Work daily with the youth involved in the Yethiyatanunha Program. Assisting with credit recovery and day to day struggles with family and friends through discussion and group. Attended Tribal Action Plan training in South Carolina with Council Women, Fawn Billie, Behavioral Health counselor, Tina Baeten and Pricilla Belisle. Working with partners to form a strategic plan to combat drug and alcohol issues within the Nation's youth and families. On April 20th we will be bringing the Tribal Resolution for the formation of the Team to the QOL, and then to the BC for approval. Once approval is made the initial team will invite vested members of the community to join the coordinating committee and the full community readiness assessment will begin with assistance from Sepriano Lacario from SAMSA. Wrote and submitted the Coordinated Tribal Assistance Solicitation (CTAS) purpose area 9. This grant if awarded will fund the continuation of the Yethiyatanunha Program for an additional 4 years. The decision on that grant will come through the 1st week of September. Planning the

Yethiyatanunha summer program with the addition of an outreach component for youth deemed most at risk entering freshman year at the Oneida High School.

11. Conservation January 2017 – March 2017

Service Calls: 7

- Feral Cats: (4) Trapped turned over to the Humane Society
- Skunk (1) Unable to locate
- Raccoon (1) Unable to locate (DOLM)
- Geese Daily riddance of Geese on Thornberry Property

CONTACTS: 17

Contacts were made during service calls and in the field

CITATIONS: 0

WARNINGS: 0

12. Internal Security

There were 1024 Incident Reports during the quarter of January 17 – March 17. The following is in part, a breakdown:

Alarm	03	Emergency Drop	23
Keywatcher	256	Medicals	106
Power Outage	01	Procedure Infraction	213
Property Damage	30	Cust/Emp Removal	137
Suspicious Activity	69	Suspicious Currency	07
Unsecure Door	27	Variance	52
Vehicle Assists	97	Cust/Emp Dispute	02

Oneida Business Committee Agenda Request

1. Meeting Date Requested: 4 / 27 / 17

2. General Information:

Session: Open Executive - See instructions for the applicable laws, then choose one:

Other - type reason

Agenda Header: Reports

Accept as Information only

Action - please describe:

Looking for approval for 3 extra meetings during the month of June for Pow-wow Preparation. This has been approved for several years now.

3. Supporting Materials

Report Resolution Contract

Other:

1. Quarterly Report

3. Admission / Attendance Report

2. Flyer/Prize Money

4. Advanced Sales Proof

Business Committee signature required

4. Budget Information

Budgeted - Tribal Contribution Budgeted - Grant Funded Unbudgeted

5. Submission

Authorized Sponsor / Liaison: Fawn Billie, Council Member

Primary Requestor/Submitter: Tonya Webster - Oneida Pow-wow Chairwomen
Your Name, Title / Dept. or Tribal Member

Additional Requestor: _____
Name, Title / Dept.

Additional Requestor: _____
Name, Title / Dept.

Oneida Business Committee Agenda Request

6. Cover Memo:

Describe the purpose, background/history, and action requested:

Pow-wow Committee Quarterly Report.

- 1) Save a copy of this form for your records.
- 2) Print this form as a *.pdf *OR* print and scan this form in as *.pdf.
- 3) E-mail this form and all supporting materials in a **SINGLE** *.pdf file to: BC_Agenda_Requests@oneidation.org

Oneida Pow-wow Committee Quarterly Report
April 2017

Chair – Tonya Webster
Vice Chair – Wayne Silas Jr.
Treasurer – Rosa Laster
Secretary- Yaziman Metoxen
Vicki Cornelius – Committee Member
Jeremy King – Committee Member
William King – Committee Member
Teresa Schuman – Committee Member
Wordon “Shane” Webster

MEETING REQUIREMENTS

The Powwow Committee shall be appointed by the OBC. The regular meeting time, place, and agenda shall be determined at a regular meeting. If no designation is made by the Powwow Committee, the regular meeting shall be the first Tuesday of the month. Stipends are currently \$50 per month. During Powwows there is a stipend of \$200 per day for members in charge of or working at services. (Security, carts, parking, tabulations, registration, admissions, concessions, etc.)

MINUTES

Our monthly minutes and meeting announcements shall be sent to the Powwow Committee, Tourism, OBC Liaison and alternate.

POW-WOWS

We had our Honor the Youth Pow-wow on February 18, 2017 at the Radisson in the three clan's ballroom. This was a very large and successful pow-wow. We had 2 invited youth drums and 17 uninvited drums set up. We normally give out meal tickets for our dancers only, but because we had so many drums this year we gave each drum 5 meal tickets because their drum split payout was so low. We had 226 registered dancers where we paid the Junior and teen dancers more than the normal rate because it was a youth pow-wow. (In 2016 we had 6 drums and 95 registered dancers.) We had a youth arena director along with an adult to learn the roles. Our specials were geared towards our Jr. and Teen categories. We also had one special for our adults. We had 21 craft vendors and 3 education vendors set up which is always good for our customers and revenue line item. Overall the pow-wow was a huge success.

REQUESTS FROM OUR LAST QUARTERLY REPORT

1. There were some concerns about our previous “Calcutta Special” was lasting too long.

- a. Solution - We won't be doing this particular special this year.
2. Opiate Drugs on pow-wow grounds.
 - a. Solution - This will be addressed with OPD when we start inviting departments to our weekly meetings starting in June.
3. Watch the parking more closely behind the vendors on the back hill.
 - a. Solution - We will monitor this more closely.
4. Remove shrubbery in front of the tennis courts to make way for an alternate route for vendor deliveries.
 - a. Solution - we worked with Norbert Hill Maintenance and Oneida Conservation to have the shrubbery removed when it gets closer to the pow-wow.
5. To include an Attendance and Revenue chart for previous pow-wows.
 - a. Solution - A chart is included.

ACTIONS TAKEN

Fundraising will become a priority throughout the fiscal year. We currently have two dates (April 29th & May 20th) reserved for a 50/50 raffle and bake sale at our bingo hall. At these fundraisers we get donations for raffles and have bake sales. We also have 50/50 raffles at our two pow-wows we do at the Radisson Hotel and Conference Center, and at other surrounding pow-wows.

UPCOMING 4TH OF JULY POW-WOW PREPARATION

- Our flyer is finished and being used for all of our advertising. – We work with Tourism on our advertising schedule. – Please see flyer attached.
- Our prize money has also been finalized. – attached (We are doing two new categories this year. Woodland & Southern for adults only)
- We have all of our head-staff selected and will be doing contracts soon.
- Contracts are done for our Golf Carts, Tents, Porta Potties, and RV's
- Our supply advance has been approved by our Finance Committee
- We have our nurses lined up for our first aide stand – NPHS Nurse Practitioner Health Services.
- Our Water Donation has been approved from Coke.
- We have a pow-wow room block set up at the Radisson (\$92) & Wingate (\$69) Hotels
- Advanced ticket sales will start on June 1st at all One-Stops. They are also available from the pow-wow committee. Advanced Weekend Tickets will be \$12 which is \$3 off regular price. – See Approved Proof
- 10 of our 12 food vendors allowed are reserved.
- 15 of our 28 craft vendors are reserved.
- Preparation will continue until the pow-wow is here.

GOALS AND OBJECTIVE

Our main goal is to coordinate three annual powwows with from our approved tribal budget and fundraising efforts.

A second goal is to generate revenues thru raffles, concessions, admissions, (July only), donations, and vendor booth sales.

REQUEST

Every year we request 3 additional pow-wow meetings during the month of June to finish our preparations and meet will all necessary business units to make the pow-wow a success. We meet with DPW, Norbert Hill Maintenance, Electricians, Planning, Gaming Security, OPD, Environmental, and nursing staff.

2012 Fourth of July Pow-wow Admission Totals June 29-July 1, 2012

	Daily Passes	Weekend Passes	Group Pass	Children/Elderly
Friday 6-29-12	533	905	171	578
Sat First Shift	1197	145	50	694
Sat Second Shift	1214	58	0	416
Saturday Totals	2411	203	50	1110
Sunday 7-1-12	568	0	0	347
Grand Total	3512 (\$7)	1108 (\$12)	221 (\$4)	2035
Grand Total = 6876 = \$38,764				

2013 Fourth of July Pow-wow Admission Totals July 5-July 7, 2013

	Daily Passes	Weekend Passes	Group Pass	Children/Elderly
Friday 7-5-13	884	779	0	849
Sat First Shift				
Sat Second Shift				
Sat. Totals 7-6-13	2058	147	10	1326
Sunday 7-7-13	420	0	0	313
Grand Total	3362 (\$7)	926 (\$12)	10 (\$4)	2488
Grand Total = 6786 = \$34,686				

2014 Fourth of July Pow-wow Admission Totals July 4-6, 2014

	Daily Passes	Weekend Passes	Group Pass	Children/Elderly
Friday 7-5-13	843	603	29	607
Sat First Shift			84	
Sat Second Shift			22	
Sat. Totals 7-6-13	2882	166	106	1060
Sunday 7-7-13	602	0	13	388
Grand Total	4327 (\$7)	769 (\$12)	148 (\$4)	2055
Grand Total = 7299 = \$40,109				

2015 Fourth of July Pow-wow Admission Totals July 3 - July 5, 2015

	Daily Passes	Weekend Passes	Group Pass	Children/Elderly
Friday	1185	823	25	911
Saturday	2203	95	43	1200
Sunday	581	0	0	483
Grand Total	3969 (\$8)	918 (\$15)	68 (\$5)	2594
Grand Total = 7549 = \$45,862				

2016 Fourth of July Pow-wow Admission Totals July 1-July 3, 2016

	Daily Passes	Weekend Passes	Group Pass	Children/Elderly
Friday 7-5-13	918	812	10	802
Sat First Shift				
Sat Second Shift				
Sat. Totals 7-6-13	2602	261	75	1385
Sunday 7-7-13	645	0	202	186
Grand Total	4165 (\$8)	1073 (\$15)	287 (\$5)	2373
Grand Total = 7898 = \$50,850				

Prize Money – 45th Annual Pow-Wow June 30 – July 2, 2017

Golden Age Women & Men 60+

Traditional

1st	\$1,100.00
2nd	\$800.00
3rd	\$600.00
4th	\$400.00

Jr. Adult Women & Men 18 – 39

Traditional / Jingle / Grass / Feather / Shawl

1st	\$1,100.00
2nd	\$800.00
3rd	\$600.00
4th	\$400.00

Teen Girls & Boys 13-17

Traditional / Jingle / Grass / Feather / Shawl

1st	\$300.00
2nd	\$250.00
3rd	\$200.00
4th	\$150.00

Junior Girls & Boys 7-12

Traditional / Jingle / Grass / Feather / Shawl

1st	\$150.00
2nd	\$125.00
3rd	\$100.00
4th	\$75.00

Drum Contest

1st	\$10,000.00
2nd	\$7,000.00
3rd	\$4,000.00
4th	\$2,000.00

Sr. Adult Women & Men 40-59

Traditional / Jingle / Grass / Feather / Shawl

1st	\$1,100.00
2nd	\$800.00
3rd	\$600.00
4th	\$400.00

Woodland Women & Men 18+

1st	\$1,100.00
2nd	\$800.00
3rd	\$600.00
4th	\$400.00

Southern Women & Men 18+

1st	\$1,100.00
2nd	\$800.00
3rd	\$600.00
4th	\$400.00

Smoke Dance Women & Men 18+

1st	\$1,100.00
2nd	\$800.00
3rd	\$600.00
4th	\$400.00

Smoke Dance Teen Girls & Boys 13-17

1st	\$300.00
2nd	\$250.00
3rd	\$200.00
4th	\$150.00

Smoke Dance Junior Girls & Boys 7-12

1st	\$150.00
2nd	\$125.00
3rd	\$100.00
4th	\$75.00

45th ANNUAL Oneida POW-WOW

June 30 – July 2, 2017 • Norbert Hill Center
5 Miles West of Green Bay on Hwy. 54

Join us in song and dance at the 45TH ANNUAL ONEIDA CONTEST
POW-WOW! OVER \$91,000 IN PRIZE MONEY WILL BE AWARDED!

MC: Terry Fiddler, Cheyenne River Sioux, Prairie Island, MN

MC: Wallace Coffey, Commanche, Lawton, OK

Arena Director: Sateko Danforth, Oneida

Arena Director: Darrell Goodwill, Dakota/Lakota, Window Rock, AZ

Head Drum Judge: Edmond Nevaquaya, Nu-Mu-Nu, Apache, OK

Head Female Dance Judge: Star White Eye, Delaware/Ojibwe, Moraviantown, Ontario

Head Male Dance Judge: Jim Red Eagle, Nakota/Dakota, Bear Butte, SD

Smoke Dance Coordinator: Jordan Smith, Mohawk, Niagara Falls, NY



Welcome Golf Fans!
www.thornberrycreeklpgaclassic.com
July 3-9, 2017

Proud Sponsors:



ONEIDA NATION ROYALTY SPECIAL
\$1,000 Men & Women Fancy Spotlight

ONEIDA POW-WOW COMMITTEE SPECIALS
Luck of the Draw – 1 category per session
4th Annual Singers Iron Man Contest
Singers Best Leads 1, 2, 3, & 4

Other Specials TBA

The Public is Welcome!

Advance tickets available
at all Oneida One-Stops
beginning June 1 for \$12.

Admission	Grand Entries	Registration
Weekend Pass \$15.00	Friday, June 30 7pm	Friday, June 30 4pm-6:30pm
Daily Pass \$8.00	Saturday, July 1 1pm & 7pm	Saturday, July 1 11am-12:30pm
60 & Older FREE	Sunday, July 2 12 Noon	
5 & under FREE		

ATTENTION DANCERS AND SINGERS

Point System competition will begin Friday, June 30. Singers please bring your own chairs. No registration fee required, but must purchase weekend pass to compete.

NO CANOPIES ALLOWED. For more information, call the Oneida Pow-Wow Committee at 920-362-5425 (Tonya), or 920-548-0122 (Rosa). Reserve your room now at the Radisson Hotel & Conf. Center, Green Bay by calling 920-494-7300, or at the Wingate Wyndham Green Bay/Airport by calling 920-617-2000. Please ask for the pow-wow room block at both hotels. Rates based on availability.



45th ANNUAL
Oneida
POW-WOW
ADVANCE
TICKET

June 30 –
July 2, 2017

Norbert Hill Center
Pow-wow Grounds,
Oneida, WI
(5 miles west of
Green Bay on
Hwy. 54

This ticket is redeemable
for one (1) weekend pass.

\$12.00

ONEIDA ONE STOP ONEIDA GOLF ONEIDA LEGAL CLASSIC

Welcome Golf Fans!
www.flornberrycreekgolfclassic.com
July 3-9, 2017

No. 1000

**GRAND
ENTRY
TIMES**

FRIDAY
June 30, 7 pm

SATURDAY
July 1, 1 pm & 7 pm

SUNDAY
July 2, 12 pm

0 00000 35672 5

Oneida Business Committee Agenda Request

1. Meeting Date Requested: 04 / 27 / 17

2. General Information:

Session: Open Executive - See instructions for the applicable laws, then choose one:

Agenda Header:

Accept as Information only

Action - please describe:

Accept SEOTS Advisory Board FY '17 2nd quarter report

3. Supporting Materials

Report Resolution Contract

Other:

1.

3.

2.

4.

Business Committee signature required

4. Budget Information

Budgeted - Tribal Contribution

Budgeted - Grant Funded

Unbudgeted

5. Submission

Authorized Sponsor / Liaison:

Primary Requestor/Submitter:

Submitted by: Peter Stevens, Interim Chair

Your Name, Title / Dept. or Tribal Member

Additional Requestor:

Name, Title / Dept.

Additional Requestor:

Name, Title / Dept.

Oneida Business Committee Agenda Request

6. Cover Memo:

Describe the purpose, background/history, and action requested:

Accept SEOTS Advisory Board FY '17 2nd quarter report

- 1) Save a copy of this form for your records.
- 2) Print this form as a *.pdf *OR* print and scan this form in as *.pdf.
- 3) E-mail this form and all supporting materials in a **SINGLE** *.pdf file to: BC_Agenda_Requests@oneidanation.org

Southeastern Oneida Tribal Services (SEOTS) Advisory Board
QUARTERLY REPORT
January 2017- April 2017

Submitted by Peter Stevens-Interim Chairperson

Members

Peter Stevens – Interim Chairman
Tina Cottrell – Board Member
Linda Langen - Board Member
Felicia Bernhardt-Board Member
Katie LaRoque-Board Member
Lloyd Ninham-Board Member

Business Committee Liaison Chairwoman Tina Danforth

Minute Updates

Minutes are on record.

Action Taken

Action was taken to fill two board position by Katie LaRoque and Lloyd Ninham with one open advisory board position remaining.

Financial

Three (3) regular Board meetings were held this quarter. Stipend expenses were submitted. The SEOTS Advisory Board budget is under budget.

Special Events and Travel

The Board will assist SEOTS with the Fry bread sale in April and the BC elections in June and July.

Goals and Objectives

The main objective of the Advisory Board was to support SEOTS with the possible creation of a pharmacy at its location.

Meeting Requirements

Twice a month (when approved by the LOC the second monthly meeting will be optional)

Follow-up

The Board has one vacant position at the end of this quarter.

New Business

The children's area at SEOTS has been completed via donations form the community.

The decadency scholarship will be tabled until the board gains further information regarding the proper set up of such funds.

The board will contact Kathy Metoxen regarding committee training to be a more effective resource for SEOTS and the community.

Oneida Business Committee Agenda Request

1. Meeting Date Requested: 04 / 27 / 17

2. General Information:

Session: Open Executive - See instructions for the applicable laws, then choose one:

Agenda Header:

Accept as Information only

Action - please describe:

Accept SEOTS Advisory Board FY '17 1st quarter report

3. Supporting Materials

Report Resolution Contract

Other:

1.

3.

2.

4.

Business Committee signature required

4. Budget Information

Budgeted - Tribal Contribution

Budgeted - Grant Funded

Unbudgeted

5. Submission

Authorized Sponsor / Liaison:

Primary Requestor/Submitter:

Submitted by: Peter Stevens, Interim Chair

Your Name, Title / Dept. or Tribal Member

Additional Requestor:

Name, Title / Dept.

Additional Requestor:

Name, Title / Dept.

Oneida Business Committee Agenda Request**6. Cover Memo:**

Describe the purpose, background/history, and action requested:

EXCERPT FROM JANUARY 26, 2017: Motion by Jennifer Webster to defer the Southeastern Oneida Tribal Services Advisory Board FY '17 1st quarter report to the next quarterly reports Business Committee meeting on April 27, 2017; and to request Tribal Secretary Lisa Summers to follow-up with the Chair of the Southeastern Oneida Tribal Services Advisory Board, seconded by Lisa Summers. Motion carried unanimously.

- 1) Save a copy of this form for your records.
- 2) Print this form as a *.pdf *OR* print and scan this form in as *.pdf.
- 3) E-mail this form and all supporting materials in a **SINGLE** *.pdf file to: BC_Agenda_Requests@oneidanation.org

Southeastern Oneida Tribal Services (SEOTS) Advisory Board
QUARTERLY REPORT
October 2016- December 2016

Submitted by Peter Stevens-Interim Chairperson

Members

Dan Schiller – Chairman
Tina Cottrell – Board Member
Linda Langen - Board Member
Pete Stevens-Board Member

Business Committee Liaison Chairwoman Tina Danforth

Minute Updates

Minutes are on record.

Action Taken

Action was taken to fill one board position by Felicia Bernhardt with three open advisory board positions still open.

Financial

Four (4) regular Board meetings were held this quarter. Stipend expenses were submitted. The SEOTS Advisory Board budget is under budget.

Special Events and Travel

No special events were planned by the Board during the quarter.

Goals and Objectives

The main objective of the Advisory Board this quarter was trying to see where it stands with membership and organizing our resources. This amount of turmoil has made long term planning ineffective.

Meeting Requirements

Twice a month (when approved by the LOC the second monthly meeting will be optional)

Follow-up

The Board has two vacant positions at the end of this quarter.

New Business

Linda Langen brought a concern from a community member regarding a children's area at the SEOTS office. Board members were thinking of a small table and chairs for children. Mark stated that SEOTS office had children furniture in storage they could be used. Mark also stated that SEOTS could purchase educational videos for children.

Renee Zakhar is scheduled to give \$300.00 towards the decadency scholarship. The board needs to ask what the process is for adding another line-item to the budget for the decadency scholarship. The board needs to discuss what the criteria will be for the scholarship fund.

Fundraising – discussion was held on having corn soup as a fund-raiser. Pete will ask St. Luke's if they would want to donate the containers and utensils for fundraiser. The advisory board will support SEOTS in their first fry bread fundraiser in January.

Felicia Bernhardt will be sworn in on October 26th as a SEOTS board member. There are still two positions vacant on the board. Tina Cottrell emailed Casey Houtsinger regarding her resignation with board.

Dan Schiller brought to the board's attention the fact that board positions should be voted on yearly. Dan Schiller is the current Chair. Tina Cottrell is filling as interim Secretary and Pete Stevens is filling in as Vice-Chair till March. Pete Stevens has agreed to be the other person for sign-off authorization along with Dan Schiller, Chairperson.

Dan Schiller will continue with making the eagle staff. Dan will also do the annual report that needs to be sent to the Business Committee.

Oneida Business Committee Agenda Request

1. Meeting Date Requested: 4 / 27 / 17

2. General Information:

Session: Open Executive - See instructions for the applicable laws, then choose one:

[Empty text box]

Agenda Header: Quarterly Report

Accept as Information only

Action - please describe:

Approval for report, a quarterly report is required of the Oneida Nation Veterans Advisory Committee to the Oneida Business Committee.

3. Supporting Materials

Report Resolution Contract

Other:

1. 2nd Quarterly Report Jan, Feb, Mar 2017

3. [Empty text box]

2. [Empty text box]

4. [Empty text box]

Business Committee signature required

4. Budget Information

Budgeted - Tribal Contribution Budgeted - Grant Funded Unbudgeted

5. Submission

Authorized Sponsor / Liaison: Jennifer Webster, Council Member

Primary Requestor: Mike Hill - Chairman
Your Name, Title / Dept. or Tribal Member

Additional Requestor: John Breuninger - Secretary
Name, Title / Dept.

Additional Requestor: _____
Name, Title / Dept.

Oneida Business Committee Agenda Request

6. Cover Memo:

Describe the purpose, background/history, and action requested:

Per Business Committee Mandate attached is the 2nd Quarterly Report for your approval.

- 1) Save a copy of this form for your records.
- 2) Print this form as a *.pdf *OR* print and scan this form in as *.pdf.
- 3) E-mail this form and all supporting materials in a **SINGLE** *.pdf file to: BC_Agenda_Requests@oneidanation.org

Michael Hill, *Chairman*
James Martin, *Vice Chairman*
John L. Breuninger, *Secretary*

Members:

Arthur Cornelius
Gerald Cornelius
Floyd J. Hill

Kenneth House
Nathan Smith
Carol Silva

Oneida Nation
Veterans Affairs Committee



April 10, 2017

Due April 18, 2017

Oneida Business Committee

ONVAC 2nd Quarter Report

MEETINGS:

JANUARY 17, 2017, FEBRUARY 22, 2017, MARCH 14, 2017

PURPOSE:

The purpose of the ONVAC is to serve as an advisory body to the Oneida Veterans Service Office in all matters related to the Oneida Tribe Veteran's rights and benefits and veterans affairs issues, and to protect the honor and integrity of the Oneida Tribe and all veterans who served honorably in the United States Armed Forces. It shall be the purpose of the ONVAC to provide advice and constructive input to the veterans Service Office Director on all veterans' affairs and/or issues in order that the Office can formulate veteran services and programs for the Oneida Veterans. ONVAC coordinates veteran events with the assistance of the Veterans Service Office and other organized groups that are representatives of Oneida Veterans and the Oneida Tribe.

SUMMARY POINTS:

BUDGET: As per the OBC's Fiscal Year 2017 directive, the ONVAC has remained well within the budget guidelines. The March 2017 R & E has not been received as of this writing and the Fiscal Year 2017 Budget

Jennifer Webster, *OBC Liaison*
Kerry Metoxen, *VSO*
Carolyn Miller, *Benefits Coordinator*

134 Riverdale Drive • Oneida, WI 54155
oneida-nsn.gov

Page 2

was passed by the GTC in April, so our next Report will provide an “up-to-date” balance of our actual budget.

JOSIAH POWLESS MEMORIAL: The ONVAC has made the determination to place a Memorial Marker at the Oneida Community Health Center in Honor of Dr. Josiah Powless, located within a “garden and walk” area currently under design. The ONVAC is further pursuing cost estimates for the development of the monument. The Memorial Marker will be somewhat comparable with the Monument currently at the Oneida Community Health Center in Honor of Dr. Minoka Hill. The ONVAC is including the immediate family members (two grandchildren) in the actual placement and wording to be placed upon the Monument. Fund raising efforts will begin soon so the Memorial can be designed, inscribed and installed.

Furthermore, the ONVAC has begun the official request process to the United States Congress for an up-grade of Dr. Powless’ Distinguished Service Cross to the Congressional Medal of Honor. This process may take up to 5 years to be officially approved by the Congress.

LAND MANAGEMENT: ONVAC & Veterans Service Officer, Mr. Kerry Metoxen are still working with Land Management regarding transferring or allocating the Veterans Memorial site to the Veterans Department. The Oneida Land Commission has approved this transfer of land and the necessary paperwork is currently being completed by the Land Management staff.

VETERAN SERVICE OFFICE: ONVAC continues to work with the VSO on :

1. The development and implementation of an Oneida Veteran Data Base. Our intent is to get an accurate as possible listing of all of our Oneida Veterans.
2. Assisting our Communities’ Veterans and Veteran Organizations.
3. Continuous upgrading and maintenance on the Veteran’s Memorial Site along HWY 54. The ONVAC wishes to thank the Department

Page 3

of Public Works (DPW) and the Tourism Department for their continued support with our efforts.

4. Selling and acquiring and installation of “pavers” for Veterans at the Memorial Site. Currently, there are 247 pavers.
5. ONVAC continues to work with the VSO to have all Civil War headstones replaced at all local cemeteries. This is a continuing process.
6. The ONVAC and VSO continue to collaborate with all of the Oneida Veterans Organizations in serving as Honor and Color Guards for GTC and other Organizational Meetings, external Veterans Activities, meetings, funerals, etc.
7. ONVAC and the VSO are also communicating and coordinating Veteran Events with the SEOTS Veterans organization.

SPECIAL EVENTS

- With the positive action by the ONVAC, VSO, Oneida Business Committee and the Legislative Operating Committee, the Oneida Nation Flag Policy is now adopted into Oneida Law. Our “thanks” go to all who have been involved in this most important legislation. Implementation plans will begin ASAP and the Veteran’s Flag Protocol will also be developed ASAP.
- ONVAC remains engaged in extracurricular activities within our Oneida Community and have assisted the Veterans Service Officer with Veterans Meetings, celebration meals, etc. Attendance
- at these events have been very good and it is great to have our Community Veterans participating in these events, along with their respective families.
-

Page 4

- Seven Oneida Nation Veterans Affairs Committee members and the Veterans Service Officer attended the 72nd Anniversary of Iwo Jima Flag Raising Ceremony in Phoenix, Arizona from February 23-26, 2017. Our members also participated in the presentation of an Eagle Feather and a Pendleton Blanket to the Gila River Indian Communities' Governor, Steven Lewis. A brief, Traditional Ceremony was conducted by a Gila River Traditional Leader and it was an Honor to Represent the Oneida Nation at that ceremony.
- Met with representative from OTIE, who made a verbal and visual presentation on the status of the OTIE and the Oneida Engineering, Science and Construction (OESC) holding company as owned by the Oneida Nation. Informed ONVAC that OESC has provided sponsorship resources for a Military/Veteran's Pavilion at the LPGA Event in July and would like our assistance in providing the best possible venue for our Military /Veteran constituents.
-
- The Tribal Affairs Office has requested the ONVAC Members be present at a Recognition Day for outgoing Congressman Reed Ribble. The event will be hosted by the OBC in their Conference. All available ONVAC Members attended to represent the Oneida Nation Veterans.
-
- HUD/BASH: Requested by the OBC in our last quarterly meeting, we would like to report that there are currently two (2) Oneida homeless veterans active within the program with an additional ten (10) being processed. Unfortunately, this is a "timely process" and work continues to assist all of the eligible applicants.

GOALS AND OBJECTIVES

-
- It is the Mission of ONVAC to ensure the Oneida Veterans are provided with quality service and assistance in the delivery of entitlement and benefits due the Oneida Veteran and their families.

Page 5

ONVAC accepts the responsibility to advocate for Oneida Veterans and their families, while protecting the integrity of the Veteran Community of the Oneida Nation

•

•

MEETING REQUIREMENTS

•

- ONVAC meetings are held the second Tuesday of each month at 5:00 pm at the Oneida Veterans Office at 134 Riverdale Drive, Oneida.
-
- ONVAC also holds “special meetings” as appropriate, to conduct business on issues of immediate concern and/or is directed by the Oneida Business Committee.
-
- All meetings are open to the public.
- .

Oneida Business Committee Agenda Request

1. Meeting Date Requested: 04 / 27 / 17

2. General Information:

Session: Open Executive - See instructions for the applicable laws, then choose one:

[Empty text box]

Agenda Header: Reports

Accept as Information only

Action - please describe:

ONCOA Bylaws require a quarterly report to the OBC

3. Supporting Materials

Report Resolution Contract

Other:

1. [Empty text box]

3. [Empty text box]

2. [Empty text box]

4. [Empty text box]

Business Committee signature required

4. Budget Information

Budgeted - Tribal Contribution Budgeted - Grant Funded Unbudgeted

5. Submission

Authorized Sponsor / Liaison: Melinda J. Danforth, Tribal Vice Chairwoman

Primary Requestor/Submitter: Patricia Lassila, ONCOA Chairwoman
Your Name, Title / Dept. or Tribal Member

Additional Requestor: Lois Strong, ONCOA Coordinator
Name, Title / Dept.

Additional Requestor: _____
Name, Title / Dept.

Oneida Business Committee Agenda Request

6. Cover Memo:

Describe the purpose, background/history, and action requested:

TO: OBC
FR: Patricia Lassila, ONCOA Chairwoman
RE: ONCOA Quarterly Report

ONCOA submits the quarterly report which is required in ONCOA Bylaws. Please reference attached report.

Thank you

- 1) Save a copy of this form for your records.
- 2) Print this form as a *.pdf *OR* print and scan this form in as *.pdf.
- 3) E-mail this form and all supporting materials in a **SINGLE** *.pdf file to: BC_Agenda_Requests@oneidanation.org

ONCOA FY17 Q2 REPORT TO OBC

April 2017

Period: January, February, March 2017

MISSION: ONCOA ADVOCATES FOR ALL SERVICES THAT PLACE PRIORITY ON THE WELL-BEING OF OUR ELDERS

ONEIDA NATION COMMISSION ON AGING

- | | |
|-------------------------------|-------------------------------|
| Patricia Lassila, Chairwoman | Carol Elm, Member |
| Arlie Doxtator, Vice Chairman | MaryAnn Kruckeberg, Member |
| Dale Webster, Secretary | Lois J. Powless, Member |
| Shirley Barber, Member | Dorothy J. Skenandore, Member |
| | Member Vacant |
- Melinda Danforth, OBC Liaison; and Lisa Summers, Alternate OBC Liaison.

Primary Focus Areas for ONCOA

- **Long Term Care Services & Support** – Alzheimer’s & Other Dementia Diseases; Affordable & Accessible Elder Housing; Adult Day Services; Personal Care Agency
- **Communication** -- Tribal Elders, Elder Service Staff and Community
- **Training & Education** -- ONCOA and staff

ONCOA Meetings October, November, December 2016		
January 24	February 14 February 28	March 14 March 28

FINANCIALS

According to the financial report for period ending March 28, 2017, ONCOA is on schedule for meeting our budget projections.

MINUTES

All approved minutes are submitted to the office of the Tribal Secretary monthly.

PROJECTS/TRAINING/EDUCATION

Treasurer’s Budget Planning – FY2017, FY2018, and FY2019

- Monthly meetings continue to be held to gain understanding of guiding strategies: Vision, Mission, Core Values, Four Strategic Directions, Seven Practical Visions and Value Based Budgeting.
- Presentation areas: Federal Election Review, Market Outlook & Economic Forecast for FY2017, Develop contingency plans with potential budget impacts, Report success per FY2017 Operation Plans, Right-size employment initiative/Minimum staffing levels.

ONCOA FY17 Q2 REPORT TO OBC

April 2017

Period: January, February, March 2017

Solar Deployment On Tribal Facilities, Michael Troge, Environmental Project Manager

Michael Troge provided information of electrical use per building and OCHC electrical diagram. He went over the latest project details per building. The Project Installation will cost \$2 Million. 1 Million is covered by a grant. The other 1 Million will be covered by an investor\Partner. Tribe's Solar Bill will be \$80,000.00 per year for 6 years. Estimated Maintenance per year is \$15,000.00 per year. Tribal Solar costs are \$65,000.00 per year. Installation price is \$2,556.00 per Kilowatt. Ownership Shares will flip on Year 7 = Buyout estimated cost is \$100,000.00 for the Oneida Tribe to be full owner. Strategy equals solar bill = utility bill. Agreements are still under negotiation. Oneida Nation and SunVest form a partnership which is called the Oneida Nation Solar, LLC and has direct oversight of the two partners. The Oneida Nation Solar, LLC may be dissolved after the Operating Agreement has conclude (year 7). The Operating Agreement defines the relationship between the two entities.

Hempstead Project Heart, Marcus Grignon

Marcus Grignon was here to provide an Educational Aspect for Hemp Production and Hemp Products for all kinds of uses. There were textile materials, medicinal opportunities for pain reduction, candy, socks, t shirts, shoes, clothing, Hemp Crete Bricks and insulation for homes (resists mold, fire resistant, animal resistant), and paper products, etc. that can be made of Hemp. Seeds can be used in Yogurt, salads, and other foods. It is now in Dr. Braunor's Soap sold at Target, Pik N Save, Festival Foods, and Woodman's Stores. Hemp Oil can be used for Arthritis.

The first step is to talk and educate the community about the uses of Hemp. Call your State Representatives, State Legislators, to recommend support for Hemp Production. Google State Legislature Council for names of legislators to make contact with. State Legislators need to craft current policy for the State of Wisconsin in order to allow Hemp Production in the State of Wisconsin.

ONCOA Orientation

- The annual ONCOA orientation was held in February with the assistance of Wendel Holt from the Great Lake Intertribal Council. Usually Elder Service staff participates to inform ONCOA about the services that are offered. We will ask for them to meet with ONCOA at a later date when the department is more settled from changes in management.

ONCOA Bylaw Review

- ONCOA is undertaking a thorough review of the bylaws. Terry Hetzel, Continuous Improvement/Mediation Specialist, is assisting us in completing the analysis.

Nutrition Advisory Board

- ONCOA participates on this board which meets once a month.
- The Mealsite Nutrition Assessment was completed for the 2016-2018 plan assessment period in order to review all items surrounding the functions of the nutrition programs under the Older American's Act including the following areas: Administrative Functions,

ONCOA FY17 Q2 REPORT TO OBC

April 2017

Period: January, February, March 2017

Income Sources, Congregate Nutrition Programming, Home Delivered Meal Programming, Food Safety and Sanitation and Other Nutrition Services.

- The report states that no sections of the assessment were out of compliance. Further the reporter stated that Oneida Elder Services employs experienced, well-trained staff, which acts with the Elders' best interests at all times. The staff put a lot of effort into making the Nutrition Program a success and they really work well as a team.
- Loretta Mencheski is the Elder Services, Mealsite Supervisor. ONCOA thanked her for her hard work in continuing to serve the Elders with opportunities for healthy meals, quality education, numerous socialization opportunities, and improved health.

Elder Tree

- The Elder Tree Project is an effort to spread technology that will help older adults remain independent, living in their home as long as possible. Participants will be provided an Ipad and WiFi access along with training to use the Ipad and Wifi service. This project was developed at the University of Wisconsin-Madison.
- Ten adult "Champions" from the Oneida community have been selected to be trained on Elder Tree to help build a base of users in the community.
- ONCOA is collaborating with University of Wisconsin - Madison to develop a Baldwin Grant which will provide access to computer/internet technology and the Elder Tree Website for 25 elders who are members of the Oneida Nation in order to improve communication; access to tribal information; establish a group of community Elder Tree Coaches; and spread the Oneida Elder Tree experience to the other 10 tribes in Wisconsin.
- **Status April 2017: The Pre-Proposal submitted was approved for the next selection phase of the grant. There is a strong possibility that Oneida will be awarded the grant as the Baldwin grant wants to focus on projects benefiting people living in Wisconsin. Oneida Enrollment statistics utilized in the grant showed that the Oneida Elders in Wisconsin have increased by 128% from 1999 to 2016.**

Elder Village – Redesign of Phase II of ten Cottages

- Affordable and accessible housing for our elders is a priority need in our community. To address this need, ONCOA played a major role in identifying the Elder Village Concept as a neighborhood that would enhance "Quality of Life" principles for elders. The cottages are unique with materials, varied layout, and are in a park-like setting with ample green space surrounding the homes. There is a trail connection to other Oneida areas like Site I, Turtle School, and eventually Site II. The Elder Village Cottages meet the minimum ADA standards.
- A project team has been formed to redesign Phase II of the next ten cottages. Representatives include the following areas: ONCOA, Oneida Housing Authority, Senior Architect, Planning and Solar Energy,
- The plan is to start over with the redesign instead of modifying the existing plan and to take into account the best quality of life needs for the elder. There will be some minor adjustments for the future cottages as well as considering smaller units to keep cost down. Solar panels for future homes were discussed. The bedrooms and garages need ADA clearance. We need to have a discussion about the total costs of the cottages. It's

ONCOA FY17 Q2 REPORT TO OBC**April 2017****Period: January, February, March 2017**

not just about the design. For example, the bidding package could be broken down so we get more potential contractors working at the same time.

- **Status April 2017: An architect has been selected to provide designs for Phase II of the cottage designs. ONCOA has been participating as part of the Design Selection Team. The plan is to have final designs ready by May. Look for construction to begin soon.**

Adult Day Services

- ONCOA has identified the need for Adult Day Services and garages for the Tribal Elder Apartments. The Adult Day Services was deleted from the original ORCCC project and slated for a future development CIP. These projects are related to the development of the Lee McLester II Complex. ONCOA will be working with Elder Services to support moving these projects forward.
- ONCOA will start researching adult day care programs.
- **Status Adult Day Services: No movement on this project during this past quarter and need input from Elder Service Director on how they would like to proceed on this project.**

Tribal Elder Apartment Garages

- In **February, 2005** Elder Services started the plans for a capital improvement project request for garages for tenants occupying the Elder Service apartments. Project justification continues to be for health and safety issues. Due to the existing building being located on top of a hill it can be extremely windy with harsh weather conditions. Elders are especially susceptible to health problems caused by these conditions and it can be very difficult for elders to get to and from their vehicles in inclement weather.
- **Status Apartment Garages:** The GSD Division Director has approved and signed off on the CIP package and the project now needs approval at the OBC level. Currently there is approximately \$48,000 available to continue planning for this project. There has been no movement on this project during this quarter. **Elder Service Director needs to decide how they want to proceed on this project. In addition, the next phase of the project needs to be included in the FY2018 budget. Elder Services Direct needs to submit this CIP request.**

Alzheimer's Awareness and Research Initiative

- In **December 2014**, ONCOA connected with the Wisconsin Alzheimer's Disease Research Center after meeting representatives at the Annual Wisconsin Alzheimer's conference. The UW-Madison's Alzheimer Disease Research Center is one of the Nation's leading research centers providing scientific research, resources, and expertise in Alzheimer's disease and related illnesses. ONCOA supports Oneida tribal members to expand their awareness of Alzheimer's disease and other dementias and to participate in the national effort to end Alzheimer's.
- In **May, 2015**, Dr. Dorothy Farrar-Edwards, Dr. Carey Gleason, Fabu Carter and Carol Hutchinson from the University of Wisconsin School of Medicine and Public Health Alzheimer's disease Research Center (ADRC) met with Oneida elders and others at the mealsite to provide Alzheimer's disease information.

ONCOA FY17 Q2 REPORT TO OBC

April 2017

Period: January, February, March 2017

- ONCOA held a meeting with Dr. Dorothy Edwards and Dr. Carey Gleason to discuss the potential collaboration between Oneida and UW-Madison's Alzheimer's disease Research Center. Potential areas of collaboration are: Training Dementia Care Specialist; Community Education; Promoting Timely Recognition of Memory Disorders; Connecting to Oneida Health Center and Anna John RCCC. The Green Bay area has a large Native population and would be ideal for a satellite center for a UW-Madison Alzheimer's Resource Center.
- **Alzheimer's Clinical Trials**-- ONCOA continues to work on encouraging tribal members to become participants in Alzheimer's clinic trials. There is very little information on Native Americans that would indicate how prevalent the disease is in Indian country. We can fight this disease by becoming research volunteers who provide critical data needed to move science forward. Several Oneida volunteers have already signed up and are encouraging others to participate.
- **Status April:** The UW-Madison Research team will meet in Oneida to

Long Term Care Group

- A Long Term Care (LTC) group consisting of representatives from Oneida Health Center, Governmental Services, and ONCOA has been formed to develop a strategic LTC-Services and Supports plan for Oneida. Out of this larger group a core team has been formed.
- Lately, the Core Team (Health Center, GSD, Elder Services, ONCOA, Law) have been meeting to work on the **Tribal Only Waiver**. The Tribally operated Medicaid (low income) Home and Community Based Services (HCBS) waiver is an option for Wisconsin American Indian Tribes to provide long term supports for adults with long-term care needs in Wisconsin. This waiver is important because it aligns administration with the unique authorities of Tribal Governments, and assures that services will meet the unique needs of tribal members when meeting their long term care needs.
- During the past months the Waiver Plan was changed to Tribally Operated Waiver. It is expected that solutions will be developed to narrow the health care gap in critical risk areas experienced disproportionately among American Indians.
- The Tribal Only Waiver will allow for 100% reimbursement at the federal level directly to tribes. The State will then not have to pay a percentage of the eligible service. We have not received any notification that the Tribal Only Waiver has been approved.
- **Status:** The **Tribal Long Term Care Study Group**, consisting of State and Tribal representatives, continues to work with CMS to get the Tribal Waiver approved. These are monthly meetings. No resolve has been reached with CMA regarding the Tribal Waiver category approved for Wisconsin.

Money Follows the Person (MFP) Tribal Initiative

- The Centers for Medicare and Medicaid Services is offering states and tribes between \$850,000 and \$1.93 million in grant funding in order to build sustainable community-based Long Term Services and supports specifically for Tribal Members. Wisconsin must have an active partnership with the participating tribes or tribal organizations in order to be eligible for the grant.
- The project Oneida has selected to develop is a **Tribal Personal Care Agency** along with needed infrastructure to deliver Long Term Care services to Oneida Tribal Members. Having a Personal Care Agency will allow **Elder Services and Oneida Health Center** to obtain Third Party Billing Payments through Medicaid for In-Home Care and Home Chore Services. Currently, Oneida provides In-Home Care and Home Chore Services that are paid through

ONCOA FY17 Q2 REPORT TO OBC**April 2017****Period: January, February, March 2017**

Tribal Contribution. In the future, Elder Services could potentially increase these services utilizing the third party reimbursement received by the Tribe.

- ONCOA supports having a personal care agency to help defray Tribal Contribution costs to the Elder Service budget. The reimbursement will come from those services provided to clients who meet low income eligibility (Medicaid) and are eligible for the COP program. The COP program will expire in December, 2017 and those services will then come through managed care.
- **Status April: David Larson, OCHC Ancillary Services Director, is the main person in charge of this grant for Oneida. ONCOA received notice from Ashley Hesse, DHS representative, that in late March the DHS Tribal Affairs Office released the MFPTI Phase III solicitation to all tribes. This opportunity can provide up to \$75000 to support development or enhancement of Home and Community Based Services (HCBS) programs provided by tribes. Ashley Hesse is available to meet with us to discuss the MFPTI grant or provide technical assistance to aid in the development of our designated project---a personal care agency. ONCOA sent a request to David Larson to set up a meeting to review our progress on developing a personal care agency.**

Great Lakes Native American Elders Association (GLNAEA)

- GLNAEA meetings are held quarterly and membership is comprised of elders from the eleven tribes in Wisconsin. Each tribe takes a turn at sponsoring a meeting on their reservation. Tribal news and current issues in Indian country are discussed at the meetings. Social interaction between the tribes is an important aspect of the association that keeps members participating in the meetings.
- These meetings are held quarterly with various host tribes. Each tribe handles their own notifications of dates and locations. The Oneida Chairwoman has committed to holding the September 2018 GLNAEA meeting.

Webinars

- **No webinar training has been made available to ONCOA in the months of January, February, and March. These webinars are planned through Elder Services and an offer to participate is extended to ONCOA.**
- **Status April: ONCOA scheduled two webinars in April and extended an invitation to Elder Service Director for ES staff to attend. Webinars: 1. Native American and Research Communities Uniting to Fight Alzheimer's Disease 2. Strategic Planning – Seminole Native Learning Center**

Wisconsin Tribal Aging Directors Association

- ONCOA members did participate in these monthly meetings. All eleven tribes belong to this association and meet to discuss Aging Issues in Indian Country and to formulate ways to best meet the needs of our Native Elders. This is a very informative meeting.
- This was a collaborative relationship that ONCOA has maintained with Elders Services and the other tribes since the inception of the organization.
- ONCOA has not participated in any of these meetings with Elder Services Director during January, February, and March 2017.

Elder Service Staff Meetings

- Elder Service Staff Meetings are still held on the first Tuesday of each month but ONCOA has been asked to not attend any further "All Staff" meetings.

ONCOA FY17 Q2 REPORT TO OBC

April 2017

Period: January, February, March 2017

- In the past, these meetings provided an opportunity to ONCOA to maintain a relationship with all Elder Staff where monthly calendar of events, speakers, and staff information comprised the agenda.

Title V – Senior Community Service Employment Program (SCSEP)

- SCSEP is Elder job training funded through a grant from the U.S. Dept. of Labor.
- ONCOA has employed Title V staff for the past 8 years and we have always had great success working with the Title V program. Since our budget is limited we seek out resources to assist us in meeting our administrative needs.
- **Status:** We have one applicant who is going through the approval process with the Title V program through National Indian Council on Aging (NICOA).

Commentary

- ONCOA has been told that re-organization within Elder Services is going to happen. This may be positive change but we don't know because we have not received any information on the comprehensive re-organization plan or any rationale to support the changes. ONCOA plays a critical role in advising and supporting the Elder Service programs therefore we need to be informed of the future of Elder Services. Change can occur in a positive manner especially if staff know what is going to happen and rationale to support the change. ONCOA has invited George Skenandore, GSD Director, to attend our next ONCOA meeting on April 25th. We hope this will be an informative meeting.

Meeting Requirements

ONCOA meets on the second and fourth Tuesday of each month at 1:00 p.m. in the Elder Services, Conference Room. Special Meetings are held during the month to address specific topics related to the goals and objectives of ONCOA. Meetings are open and community members are encouraged to attend. Dates and times of meetings are published in the DRUMS.

GOALS

GOAL I	ONCOA will create policies and work together with Elder Services in an effort to improve the quality of life of our Elders.
GOAL II	ONCOA will communicate with Elders on issues, policies and services in order to increase their awareness and participation.
GOAL III	ONCOA will advocate at all levels (tribal, local, state, national) for resources to provide for elder services

ONCOA FY17 Q2 REPORT TO OBC
April 2017
Period: January, February, March 2017

COMMENTS

Each commissioner, along with the ONCOA staff, brings with him/her a varied background of employment, life experiences, education, and community/state/national involvement to work toward a common goal of advocating for services that place emphasis on our elders. The following list demonstrates the extent of current community/state/national involvement for the ONCOA commissioners and staff:

Oneida Nutrition Board	Anna John RCCC Board
National Indian Council on Aging (NICOA) Auxiliary	Veterans of Foreign Wars (VFW)
Oneida Police Commission	Oneida Child Protective Board
National Indian Child Welfare Association	
Great Lakes Native American Elders Association, members	

Oneida Business Committee Agenda Request

1. Meeting Date Requested: 04 / 27 / 17

2. General Information:

Session: Open Executive - See instructions for the applicable laws, then choose one:

Agenda Header:

Accept as Information only

Action - please describe:

Accept OGC 2nd Qtr Report

3. Supporting Materials

Report Resolution Contract

Other:

1. 3.

2. 4.

Business Committee signature required

4. Budget Information

Budgeted - Tribal Contribution Budgeted - Grant Funded Unbudgeted

5. Submission

Authorized Sponsor / Liaison:

Primary Requestor: Mark A. Powless Sr., OGC Chairman
Your Name, Title / Dept. or Tribal Member

Additional Requestor: Tamara Van Schyndel, Executive Director
Name, Title / Dept.

Additional Requestor: _____
Name, Title / Dept.

Oneida Business Committee Agenda Request

6. Cover Memo:

Describe the purpose, background/history, and action requested:

Accept OGC 2nd Qtr Report

1) Save a copy of this form for your records.

2) Print this form as a *.pdf *OR* print and scan this form in as *.pdf.

3) E-mail this form and all supporting materials in a **SINGLE** *.pdf file to: BC_Agenda_Requests@oneidanation.org

ONEIDA GAMING COMMISSION QUARTERLY REPORT

FY 2017 First Quarter: January, February, and March

Prepared on April 18, 2017

Article I. Purpose

The purpose of the Oneida Gaming Commission (OGC) is to protect the assets and integrity of Oneida Gaming through regulatory oversight. The OGC regulatory oversight leads to current and consistent regulatory practices within the gaming operation.

Article II. Names

2-1. There are four (4) full time Commissioners which include: Chairman- Mark A. Powless Sr., Vice Chair- Matthew W. Denny, Secretary- R. Tom Danforth, and Commissioner Barbra Erickson. The OGC also has an Executive Director who oversees eleven (11) staff members and the OGC also oversees thirty-eight (38) Surveillance personnel.

2-2. Report is submitted by the Oneida Gaming Commission Executive Director, Tamara Van Schyndel. The Oneida Gaming Commission can be reached by calling 920-497-5850.

2-3. The Oneida Business Committee Liaison for the Oneida Gaming Commission is Brandon Yellowbird-Stevens.

Article III. Meetings & Reports

OGC Meetings

January	01/16/17 Regular
	01/30/17 Regular
February	02/13/17 Regular
	02/27/17 Regular
March	03/13/17 Regular

Security Joint Meetings

Monthly meetings changed to quarterly intervals	
January	1 st Qtr Mtg CNX

Gaming Joint Meetings

January	01/23/17
February	02/27/17
March	CNX

Employee Investigations and Vendor Licensing

	License Investigations	Temporary Licenses (Work Permits) Approvals/Denials	New Employee Orientation & Spectra	Vendor Work Permits
January	28	151/14 Denials	28/0	63/0 Denials
February	25	74/14 Denials	25/0	12/0 Denials
March	28	169/13 Denials	28/0	56/0 Denials

Employee Licensing and Hearings

	Employees Licensed	Hearings
January	151	2
February	74	3
March	169	0

Surveillance Reports

	# of Reports
January	66
February	45
March	33

January

- 1st Quarterly Joint OBC/OGC Meeting 01/31/17
- WGRA Planning
- Surveillance System Replacement Project – presentations, evaluations, vendor chosen

February

- TGPN Women in Tribal Gaming Symposium Palm Springs, CA 01/12/17-01/15/17
- World Game Protection Conference Las Vegas, NV 01/20/17-01/24/17
- UNLV Compliance/Audit Training Las Vegas, NV 01/27/17-02/03/17
- WGRA Planning
- Surveillance System Replacement Project – assessment/discovery
- Cabling Project – site assessments, RFQ development

March

- GLI Round Table Las Vegas, NV 03/14/17-03/17/17
- NTGCR Conference Tulsa, OK 03/20/17-03/24/17
- 2nd Qtr NIGC Payment
- WGRA Planning
- Surveillance System Replacement Project – system design work
- Cabling Project – Vendor chosen

Oneida Business Committee Agenda Request

1. Meeting Date Requested: 04 / 27 / 17

2. General Information:

Session: Open Executive - See instructions for the applicable laws, then choose one:

Agenda Header:

Accept as Information only

Action - please describe:

Accept Election Board FY 2017 2nd quarter report.

3. Supporting Materials

Report Resolution Contract

Other:

1.

3.

2.

4.

Business Committee signature required

4. Budget Information

Budgeted - Tribal Contribution

Budgeted - Grant Funded

Unbudgeted

5. Submission

Authorized Sponsor / Liaison:

Primary Requestor: Racquel Hill, Election Board Chairperson
Your Name, Title / Dept. or Tribal Member

Additional Requestor: _____
Name, Title / Dept.

Additional Requestor: _____
Name, Title / Dept.

Oneida Business Committee Agenda Request

6. Cover Memo:

Describe the purpose, background/history, and action requested:

Accept Election Board FY 2017 2nd quarter report.

- 1) Save a copy of this form for your records.
- 2) Print this form as a *.pdf *OR* print and scan this form in as *.pdf.
- 3) E-mail this form and all supporting materials in a **SINGLE** *.pdf file to: BC_Agenda_Requests@oneidanation.org

ONEIDA ELECTION BOARD QUARTERLY REPORT
January – March 2017
April 19, 2017

Report Submitted By: Racquel Hill, Chairperson
Election_Board@oneidanation.org

Board Members: Teresa Schuman, Vice Chairperson
 Sunshine Wheelock, Secretary
 Gina Buenrostro
 Vicki L. Cornelius
 Constance Danforth
 Lori Elm
 Candace House
 Tonya Webster

BC Liaison: Melinda J. Danforth, Vice Chairwoman
 Alternate Lisa Summers, Tribal Secretary

Meetings:

	Regular Meeting	Special Meeting	GTC Meeting
January	1	0	0
February	1	0	1
March	1	*1	2

*Caucus of 3/25/17

Highlights for the quarter:

1. Proposed General Election date was submitted to Secretary’s Office for Annual GTC meeting (per Election Law: 2.9-1. *In accordance with Article III, Section 4 of the Tribal Constitution, elections shall be held in the month of July on a date set by the General Tribal Council. The General Tribal Council shall set the election date at the January annual meeting, or at the first GTC meeting held during a given year.* GTC approved the 2017 Caucus date of March 25th, 2017 primary date of May 6th, and 2017 general election date of July 8th.
2. Election Board went into “election cycle mode” and Caucus was held March 25, 2017 at 1:00 pm at the Norbert Hill Center, Business Committee Conference Room which was very well attended. The deadline to submit applications was March 31, 2017. Election Board has been diligently reviewing applications for both the Business Committee primary ballot and all other applications submitted for the 2017 general election ballot.

Goals and Objectives (Remain consistent):

- ❖ Conduct Tribal Elections in compliance with Tribal law.
- ❖ Develop, adopt, and review applicable standard operating procedures.
- ❖ Strive to serve the Oneida membership fairly while being fiscally responsible.

Meeting requirements: The Oneida Election Board is required to meet once per month with special meetings scheduled as needed. No special meetings were held for the 2nd quarter. FYI: Election Board has more regular meetings when in “election cycle mode” to prepare for elections.

Oneida Business Committee Agenda Request

1. Meeting Date Requested: 04 / 27 / 17

2. General Information:

Session: Open Executive - See instructions for the applicable laws, then choose one:

Other - type reason

Agenda Header:

Accept as Information only

Action - please describe:

3. Supporting Materials

Report Resolution Contract

Other:

1.

3.

2.

4.

Business Committee signature required

4. Budget Information

Budgeted - Tribal Contribution Budgeted - Grant Funded Unbudgeted

5. Submission

Authorized Sponsor / Liaison:

Primary Requestor/Submitter:
Your Name, Title / Dept. or Tribal Member

Additional Requestor:
Name, Title / Dept.

Additional Requestor:
Name, Title / Dept.

Oneida Business Committee Agenda Request

6. Cover Memo:

Describe the purpose, background/history, and action requested:

approval of 2nd quarter report for the Land Claims Commission

1) Save a copy of this form for your records.

2) Print this form as a *.pdf *OR* print and scan this form in as *.pdf.

3) E-mail this form and all supporting materials in a **SINGLE** *.pdf file to: BC_Agenda_Requests@oneidanation.org

ONEIDA LAND CLAIMS COMMISSION**2nd QUARTER REPORT**

January 1, 2017 to March 31, 2017

Submitted by Dakota Webster, LCC Secretary 920-228-0623

LAND CLAIMS COMMISSIONERS:

Officers: Chairperson- Loretta Metoxen, Vice Chair-Chris Cornelius, Secretary/Treasurer- Dakota Webster

Commissioners: Donald McLester, Tomas Escamea, Charles Wheelock

LCC Liaison: Jennifer Webster

PURPOSE:

The Oneida Land Claims Commission will make informed thoughtful recommendations to the General Tribal Council and Business Committee on issues pertaining to all Oneida land claim issues. We also encourage active participation from the membership.

MISSION:

Actively pursuing education, recommendations, and resolutions to all land claim settlement offers; honoring our ancestors, treaties, and the seven generations.

OBJECTIVES:

The Oneida Land Claims Commission is an elected governing body to meet the needs of the General Tribal Council. The Land Claims Commission is working to develop a better understanding between themselves the Business Committee and the Land Commission. The Land Claims Commission is waiting approvals from the LOC on updates to the Land Claims Commission By-Laws. The Land Claims Commission is in the process of completing a report of feedback from the surveys that have been collected and will have that report available to the Business Committee and the General Tribal Council. The Land Claims Commission website

which will be available to members only will be up and running soon finishing touches will include a time line, links to important court decisions involving land claims, and movements by the Land Claims Commission. The Land Claims Commission is working to put out another timeline for the Kalihwisaks to remind General Tribal Council of movements and people that have been involved with the land claim in New York from its inception to the present. The Commission is coordinating a viewing of a movie involving relocation and is looking into possibly putting out something on the relocation of the Oneida Nation to Wisconsin. The Land Claims Commission has started work on the FY2018 budget.

MEETINGS:

Regular scheduled meetings

January 5, 2017, January 19, 2017, February 2, 2017, February 16, 2017, March 23, 2017

Special meetings

January 31, 2017

The Land Claims Commission meets twice a month on a regular basis as scheduled; the first and third Thursday of every month at 5:30 p.m. Meeting location Cottage 2.

FOLLOW UP:

The commission is happy to report that Loretta Metoxen has finally been appointed to the Land Claims Commission. Election for officers is complete Loretta Metoxen Chairperson, Chris Cornelius Vice-Chair, and Dakota Webster Secretary / Treasurer. A special meeting was held with the Business Committee to discuss roles and concerns that the Land Claims Commission have. The discussion involved storage concerns, direction of the Land Claims Commission, and responsibilities to the General Tribal Council. Jay Rasmussen resigned from the Commission and his position will be filled in the election in July. A submission was given to the Kalihwisaks

about the anniversary of the March 4, 1985 Supreme Court victory. More investigation into Oneida Land Claims has begun and the Commission is exploring ideas of the best way to get that information back to the General Tribal Council.

Oneida Business Committee Agenda Request

1. Meeting Date Requested: 04 / 27 / 17

2. General Information:

Session: Open Executive - See instructions for the applicable laws, then choose one:

Agenda Header:

Accept as Information only

Action - please describe:

Defer Oneida Land Commission FY '17 2nd quarter report

3. Supporting Materials

Report Resolution Contract

Other:

1. <input type="text" value="Memo"/>	3. <input type="text"/>
2. <input type="text"/>	4. <input type="text"/>

Business Committee signature required

4. Budget Information

Budgeted - Tribal Contribution Budgeted - Grant Funded Unbudgeted

5. Submission

Authorized Sponsor / Liaison:

Primary Requestor/Submitter: Submitted by: Jay Rasmussen, Oneida Land Commission Secretary
Your Name, Title / Dept. or Tribal Member

Additional Requestor: _____
Name, Title / Dept.

Additional Requestor: _____
Name, Title / Dept.

TO: ONEIDA BUSINESS COMMITTEE
FROM: JAY T. RASMUSSEN, ONEIDA LAND COMMISSION SECRETARY
SUBJECT: REQUEST FOR DEFERRAL
DATE: APRIL 21, 2017

This memorandum serves as a formal request for deferral of the Oneida Land Commission second (2) quarter reporting requirements.

The report is in final draft form. The report needs final approval from the Oneida Land Commission at their acquisition meeting to be held on April 24, 2017.

If you should have further questions/concerns please feel free to contact me via e-mail at jrasmuss@oneidanation.org.

Oneida Business Committee Agenda Request

1. Meeting Date Requested: 04 / 27 / 17

2. General Information:

Session: Open Executive - See instructions for the applicable laws, then choose one:

Agenda Header:

Accept as Information only

Action - please describe:

3. Supporting Materials

Report Resolution Contract

Other:

1.

3.

2.

4.

Business Committee signature required

4. Budget Information

Budgeted - Tribal Contribution Budgeted - Grant Funded Unbudgeted

5. Submission

Authorized Sponsor / Liaison:

Primary Requestor/Submitter: Jay Rasmussen Land Commission Secretary
Your Name, Title / Dept. or Tribal Member

Additional Requestor: _____
Name, Title / Dept.

Additional Requestor: _____
Name, Title / Dept.

Oneida Business Committee Agenda Request

6. Cover Memo:

Describe the purpose, background/history, and action requested:

The provide a quarterly update on activities surrounding the Oneida Land Commission.

- 1) Save a copy of this form for your records.
- 2) Print this form as a *.pdf *OR* print and scan this form in as *.pdf.
- 3) E-mail this form and all supporting materials in a **SINGLE** *.pdf file to: BC_Agenda_Requests@oneidanation.org

LAND COMMISSION—(OCT.—DEC. 2016) 1ST QUARTER REPORT

2017 Goals

Direction **Committing to Build a Responsible Nation**
Vision **Accountable & Effective Governmental Design**

To support Oneida Nation business and increase revenue, the Land Commission will Identify and acquire strategic land purchases for Oneida Nation corporations and business units.

Direction **Advancing Onvyote?aka Principles**
Vision **Long Term Sustainability Plans**

The Land Commission has developed a program for a land ONLY purchase process; this allows membership more options in financing, the ability to acquire a home that fits their individual needs, maximizes the use of acquisition funds, and reduces risk to the Oneida Nation.

Direction **Creating a Positive Organizational Culture**
Vision **Accountable & Effective Governmental Design**

Recommended edits and changes for the by-laws will be submitted to the Legislative Operating Committee regarding Land Commissioner qualifications. The by-laws will outline specifications to Real Property Law class and/or equivalent hours, specified subject matter training , or completes specified training within one year of election .

MISSION

“The Land Commission is an elected body of policy makers for Land issues. The Commission oversees land acquisitions, leases, mortgage loans, land use, probates and all other tribal land issues.”

Oneida Land Commission Members

- Rae Skenandore, Chairperson
- Racquel Hill, Vice-Chairperson
- Jay Rasmussen, Secretary
- Donald McLester, Commissioner
- Sherrole Benton, Commissioner
- Lloyd Powless, Jr., Commissioner
- Rebecca Webster, Commissioner

Meetings

Regular meetings are the 2nd Monday monthly. Acquisition Meetings are the 4th Monday monthly.

Meeting and Hearing Stipends

Meetings	\$ 50.00
Eviction Hearings	\$ 50.00
Probate Hearings	\$ 50.00
Foreclosure Hearings	\$150.00

** Note a hearing body consists of 3 members*

ACQUISITIONS—First Quarter

- ◆ Eleven (11) acquisitions
- ◆ 9.13 acres acquired

Oneida currently owns 26384.19 acres or 40.3% of the original reservation.

The Oneida Land Commission is not a real estate developer. Future development decisions occur in another area of the Tribe.

First Quarter Meetings

- 3 Regular meetings
- 3 Acquisition meetings
- 1 Special Meetings
- 1 Joint meeting

First Quarter Hearings

- 1 Eviction
- 1 Foreclosures

LAND COMMISSION—(OCT.—DEC. 2016)**FIRST QUARTER SUMMARY****Update on Strategic Goals**

- ◆ A strategic commercial property was acquired in June of 2016. As part of the purchase agreement the former owner occupied the facility/building until December 2016. Gaming will be conducting a feasibility study which will focus on producing revenue for the Oneida Nation. Details have not been "ironed out."
- ◆ The Homeownership for Independent Purchase (HIP) program saw eight (8) additional purchases during the first (1) quarter of FY 2017.
- ◆ The Land Commission, Department of Land Management, Legislative Operating Committee, Bay Bank and Legal continue to develop administrative rules for a Phase II of the HIP program. Tribal Housing Reacquisition of Individual Fee and Trust Title (THRIFTT) Program would allow Nation homeowners to sell their land to the Nation. THRIFTT will be rolled out FY 2017.
- ◆ The Land Commission By-laws are being amended as the new laws come forward for approval. The By-laws will include a required training.
- ◆ The Leasing Law revisions are awaiting final approvals from the Bureau of Indian Affairs (BIA.) A public meeting was held on May 19, 2016.
- ◆ The Mortgage Law revisions and approvals are coming to finalization. A public meeting was held on June 30, 2016.
- ◆ The Landlord Tenant Law revisions and approvals are coming to finalization. A public meeting was held July 21, 2016

Other Highlights

- ◆ The Land Commission is in the process of examining, developing and implementing plans for the FY '17 budget.
- ◆ The Oneida Nation acquired 6.5 acres of vacant trust land.
- ◆ Land Commission has officially moved all meetings to Little Bear Development Center per audit findings. This has been officially posted for Oneida Nation members.
- ◆ Joint Land Commission/Business Committee meeting was held on October 20, 2016.
- ◆ The Land Commission would like to welcome to our team Lloyd Powless and Rebecca "Becky" Webster. Both individuals have worked extensively with the Land Commission in the past.

BC ACTION NEEDED: REQUEST BUSINESS COMMITTEE TO ACCEPT THE LAND COMMISSION FIRST (1)QUARTER REPORT FOR FISCAL YEAR 2017

Oneida Business Committee Agenda Request

1. Meeting Date Requested: 4 / 27 / 17

2. General Information:

Session: Open Executive - See instructions for the applicable laws, then choose one:

Agenda Header:

Accept as Information only

Action - please describe:

Accept Oneida Nation School Board FY '17 2nd quarter report

3. Supporting Materials

Report Resolution Contract

Other:

1.

3.

2.

4.

Business Committee signature required

4. Budget Information

Budgeted - Tribal Contribution

Budgeted - Grant Funded

Unbudgeted

5. Submission

Authorized Sponsor / Liaison:

Primary Requestor/Submitter: Submitted by School Board Administrative Assistant, Jolene Hensberger
Your Name, Title / Dept. or Tribal Member

Additional Requestor: _____
Name, Title / Dept.

Additional Requestor: _____
Name, Title / Dept.

Oneida Business Committee Agenda Request

6. Cover Memo:

Describe the purpose, background/history, and action requested:

The Oneida Nation School Board is requested to provide quarterly updates to the Oneida Business Committee. This update is from January until April 2017.

- 1) Save a copy of this form for your records.
- 2) Print this form as a *.pdf *OR* print and scan this form in as *.pdf.
- 3) E-mail this form and all supporting materials in a **SINGLE** *.pdf file to: BC_Agenda_Requests@oneidanation.org

ONEIDA NATION SCHOOL SYSTEM

Oneida Nation Elementary School
 P.O. Box 365
 N7125 Seminary Road
 Oneida, WI 54155
 Phone (920) 869-1676
 FAX (920) 869-1684



Oneida Nation High School
 P.O. Box 365
 N7210 Seminary Road
 Oneida, WI 54155
 Phone (920) 869-4308
 FAX (920) 869-4045

April 18, 2017

- BOARD:** Oneida Nation School Board
- MEMBERS:** Debra Danforth, Chair
 Fred Muscavitch, Vice Chair
 Rhiannon Metoxen, Secretary
 Melinda K. Danforth, member At-large
 Todd Hill, Parent Member
 Shanna Torres, Parent Member
 Margaret R. Ellis, Parent Member
- CONTACT PERSON:** Rhiannon Metoxen
OBC LIAISON: Fawn Billie
- MINUTES:** January 2017
 February 2017
 March 2017

UPDATES

January - April student enrollment: K-5 = 334 9-12 = 125 Total = 459

The Oneida Nation School System had recently lost a dedicated High School staff member, Becky Nutt, who put forth great effort and devotion to our students. Ms. Nutt spent twenty years as a high school science teacher. During that time she taught students much about environmental science and traveled to many Science Fairs with students who would return as winners in the competitions. She was a Toyota Tapestry Grant recipient and also was nominated several times for the Golden Apple Award. She was on the committee responsible for writing State Science Standards and was one of few teachers who continued to work towards the National Certification of Teacher Program, supported through the BIE. She received a Walmart Teacher of the Distinction Award and earned her Master’s degree to improve her talents in her science classroom, while teaching at ONHS. Ms. Becky Nutt loved science, loved teaching science and loved teaching at ONHS. She will be greatly missed.

The Oneida Nation School Board is excited to announce that it has gained a new member, Margaret R. Ellis, to fill a Parent Position. The Board is grateful for her dedication and looks forward to working with her. We have recently had one member, Neset Skenandore, resign. We thank her for her service and wish her well in her future endeavors.

We would also like to congratulate one of our Language and Culture Staff, Stephenie Muscavitch Van-Every for being selected as a 2017 Herb Kohl Teacher of the Year recipient! She will be receiving her award at a banquet on Saturday, April 22nd at the Red Smith School in Green Bay, WI.

The School Board has been reviewing and updating the Education Law (Code), which was previously submitted to the LOC years ago. The next review session is scheduled on April 22, 2017 with the presence of the School Board Attorney. This Law will help give better direction and unity to our community in regards to education from birth to grave. Areas containing educational goals will be able to better collaborate with each other to increase support, guidance, and educational opportunities for our members.

The Oneida Language House recently met with the Oneida Nation School Board to discuss a transitional opportunity for both the Oneida Nation School System, as well as the Language House. Before the School Board could take any action, they met with the Oneida Business Committee to obtain direction and approval to transition the Oneida Language House under the Oneida Nation School Board; a resolution is being worked on by the Business Committee. This transition will not only help the Language House to work with long term candidates, but will also help our youth to further their knowledge and understanding of the Oneida Language. Our youth receiving the Language House's curriculum will be able to bring the teachings home to their families. The restoration of our culture and language is critical to our Nation.

The Oneida Nation School System is seeking qualified teaching staff to fill soon-to-be vacant positions for the 2017-2018 school year as some of our staff will be retiring. Substitute teachers are currently covering various positions to get us through the end of the year. In addition, our School Liaison, Officer Lyle Metoxen, will be retiring. We thank him for his 15 years of service to our School System and appreciate everything he has done for our youth.

In 2016, the Oneida Nation School System had been announced as a recipient in a class action law suit in the Ramah Navajo case, where the Bureau of Indian Education failed to provide funding for administrative costs. The School Board and School Administrator have decided it best to invest a large portion of this money to protect and enhance the Oneida Nation School System's educational teaching tools and goals. The next step to this investment process is holding a meeting with the Trust Enrollment Committee to find the best investment strategy.

GOALS AND OBJECTIVES

Our students continue to increase their knowledge of Oneida language and culture, as they attend language / culture and social dance classes as part of their daily education. The Maple Syrup season went well with both schools and the Maple Luncheon was well attended on April 7th. Staff are organizing the final plans for the May Oneida Language/Culture Day activities. Language House classes have begun after school for elementary students, while some small group instruction is continuing with staff from the Language House. Administration is currently working with the grants office and Language House staff to submit a grant to obtain funding to enhance the language program outreach to families.

The Indistar online reporting system with the BIE has identified specific goals and objectives for schools to develop which are reported on a quarterly basis. Smart goals are formulated around the academic subjects of reading, math, science and social studies, with reform strategies for students which include response to intervention small grouping for focus on specific academic goals. BIE Grants and reports in Indistar are due May 15th, 2017. Staff are working on the analysis of this year's progress and setting goals for next school year.

A group of administrative staff attended an AdvancEd Accreditation training in Pewaukee, WI on April 6th. Oneida Nation School System is due for a five year review in March of 2018. The diagnostics, survey tools and inventories have all been changed to be online through a system called e Prove. We needed to attend the training to have access to these tools to be prepared for the upcoming visit.

Improving student daily attendance, high school graduation rate, and raising the reading and mathematics academic levels still continue to be the overall goals for this school year. Students in 3rd through 8th grade and 10th grade were administered the State of Wisconsin, Forward Exam, as required by the BIE as an indicator of student progress, this April.

MEETING REQUIREMENTS

The Oneida Nation School Board holds open meetings the first Monday of every month at 5:00 p.m. in the library at the Elementary School. Special meetings are held when deemed necessary and duly called by the School Board Chair.

Oneida Nation School Board
Special Meeting

Date: Friday, January 13, 2017

Time: 12:00 p.m.

Place: Elementary School Main Office Conference Room

PRESENT: Debra J. Danforth, Fred Muscavitch, Margaret R. Ellis, Melinda K. Danforth, Rhiannon "RC" Metoxen, Shanna Torres, Todd "Moon" Hill**EXCUSED:** Neset Skenandore**OTHERS:** Sheri Mousseau**TIME:** 12:00 p.m.

- I:** Discussion and review of Education Code [Law]
The Education Code was initiated to improve the overall education plan for community members from birth to grave – all areas and departments that include any type of educational intent, and to contain these areas under one umbrella instead of having multiple that may or may not be collaborating with each other.
- II:** Welcome to the new School Board member, Margaret R. Ellis
Margaret R. Ellis (Kwaklit) took her Oath of Office on January 11, 2017.
- III.** Closing remarks
School Board Retreat to discuss the Education Code [Law] with School Board Attorney will be tomorrow, Saturday, January 14 from 8:00 a.m. until noon. Members need to review the Education Code to be prepared for the meeting.
- IV.** Adjourn: *RC motioned to adjourn at 1:00 p.m. Melinda K. Danforth seconded. Motion carried.*

Respectfully submitted,

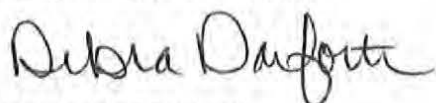
Rhiannon Metoxen
Secretary
Oneida Nation School Boardapproved / corrected on 4-15-17
Date

Oneida Nation School Board
Retreat

Date: Saturday, January 14, 2017

Time: 8:00 a.m. - Noon

Place: Radisson Hotel & Conference Center

PRESENT: Debra J. Danforth, Fred Muscavitch, Melinda K. Danforth, Rhiannon "RC" Metoxen, Shanna Torres, Todd "Moon" Hill

EXCUSED: Neset Skenandore, Margaret R. Ellis

OTHERS: Sheri Mousseau, Artley Skenandore, School Board Attorney, Joanne Harmon Curry

OPENING: Artley Skenandore

Called to Order: Debbie Danforth

TIME: 8:28 a.m.

I: Education Code [Law]

1. History of the development of an Education Law
2. Brief review of new legislation requirements and Administrative Rule-making
3. Overview of current organization of the proposed Education Law
4. Review and discussion of sections of the law

The prior name was Education Code but has changed to Education Law. If it is not accepted and or changed, the School Board must receive justification for the reason. The scope of the School Board could be as-is.

The bulk of what is currently in the packet is just for the School System. In Draft 2 hand-out, on lines 29-34: There is a complex scheme over legal jurisdictions, such as reservation lands and trust lands, tribes have civil jurisdiction over members on their trust land. Clarification of lines 38-44 is the reservation of rights.

II: Food Service Employees

Request Linda Jenkins to provide power point presentation of 12 month wage scale options for January 18, 2017 meeting. Request Sheri Mousseau to investigate the option of a bonus for the summer months. Final decision should be determined prior to January 23, 2017.

III: Closing remarks

The Board of Education also known as the School Board is the main body for education in the community. Sections to review are 903.1 and 903.4 for changes, adding concepts, and to review purpose and policy. Topics to be discussed: What would be the scope/authority for the other entities to report to the Board of Education? Life span? Develop a list of programs to include in this scope, such as other entities. What kinds of revisions are needed?

Example diagram of entities to include under the umbrella of the Board of Education:

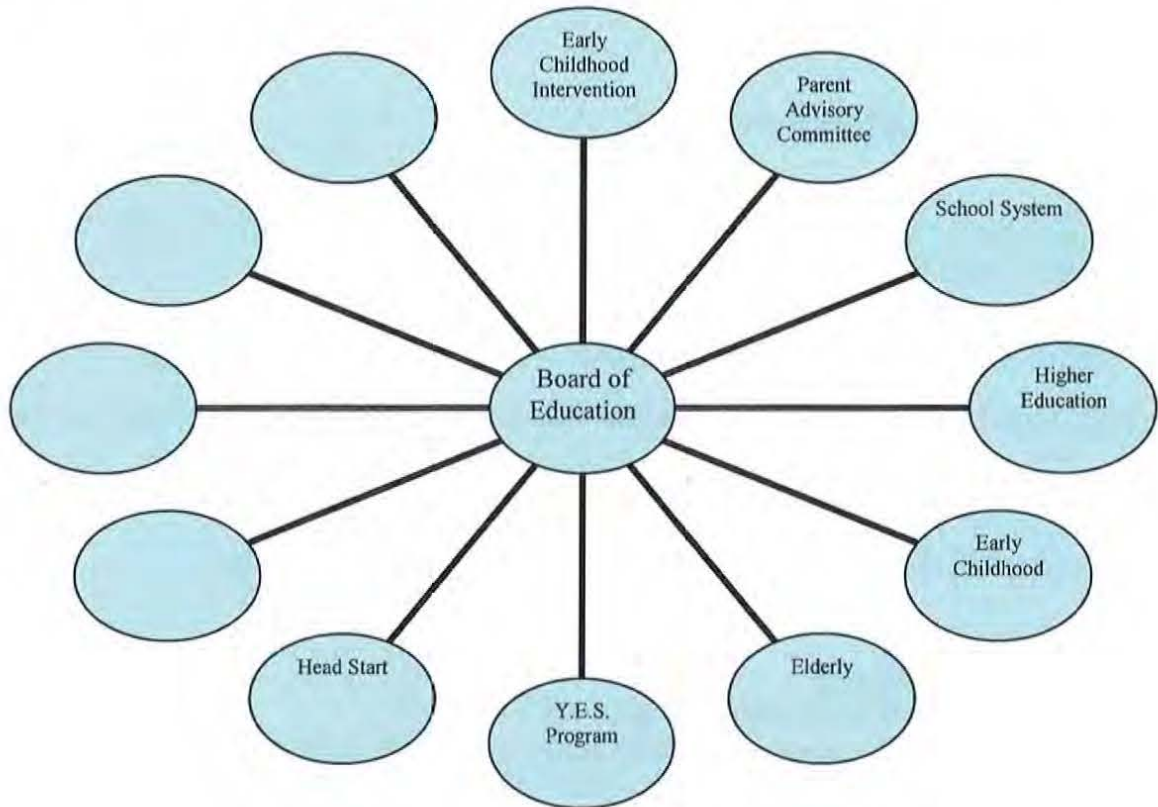

Future 2017 dates to meet on Education Law:

1. **Saturday, January 28**, 8:30 – noon at OCHC with school principals and superintendent
2. **Friday, February 10**, noon – 4:00 p.m. at ONES with school board attorney
3. **Saturday, February 18**, 8:30 – noon with school principals and superintendent at OCHC
4. **Saturday, March 4**, 8:30 a.m. - noon at Radisson Hotel with school principals, superintendent, and school board attorney.

Sheri, Art, and Debbie will work on the agenda for meeting. Debbie will contact a ToP Facilitator for meetings.

IV. Adjourn: RC motioned to adjourn at 11:15 a.m. Shanna Torres seconded. Motion carried.

Respectfully submitted,

Rhiannon Metoxen
Secretary
Oneida Nation School Board

approved / corrected on 4-15-17
Date

Oneida Nation School Board
Regular Meeting Minutes

Date: Wednesday, January 18, 2017

Time: 12:00 p.m.

Place: ONES Library

The Oneida Nation School Board is committed and accountable to students, parents, families, staff, and community members to provide regulatory oversight for a safe, positive, culturally diverse, holistic, learning atmosphere based on Onlayoté a'ka values. We will provide the expectations, resources, and educational opportunities to encourage students to be productive.

PRESENT: Debbie J. Danforth, Todd "Moon" Hill, Melinda K. Danforth, Fred Muscavitch, Margaret Ellis, Rhiannon "RC" Metoxen

EXCUSED: Neset Skenandore, Shanna Torres

OTHERS: Sheri Mousseau, Linda Jenkins, Leanne Doxtator, Tracy Christensen, Artley Skenandore, John Bestul, Fay LeMense, Leanne Doxtater, Yvette Peguero

OPENING: Artley Skenandore

CALL TO ORDER BY: Debbie J. Danforth

TIME: 12:13 p.m.

I: Approve Agenda

Fred Muscavitch approved the agenda with change of moving Planning Department presentation to first item. Melinda K. Danforth seconded. Motion carried.

II: High School Graduates

A: Special Presentation – None

III. Minutes

A: Regular Meeting – December 5, 2016

Melinda K. Danforth motioned to approve. Fred Muscavitch seconded. Motion carried.

B: Special Meetings

1. December 12, 2016 – Meeting with Administration on school-wide survey results and requests
Rhiannon "RC" Metoxen motioned to approve. Fred Muscavitch seconded. Motion carried.

2. December 19, 2016 – Prioritize and approve school-wide needs requests
Fred Muscavitch motioned to approve. Margaret Ellis seconded. Motion carried.

C: Ratification of Board Polls

1. December 8, 2016 – approval to maintain current school calendar with January mid-winter dates due to mid-winter ceremonial dates being scheduled in February.

Rhiannon "RC" Metoxen motioned to ratify. Melinda K. Danforth seconded. Motion carried.

2. December 16, 2016 – approval to have January 2 regular school board meeting changed to January 9 due to winter break and majority of staff being off.

Rhiannon "RC" Metoxen motioned to ratify. Margaret Ellis seconded. Motion carried.

3. January 06, 2017 – approval to cancel meeting with Business Committee regarding the school system’s utilization of the Ramah Navajo settlement award and to provide them with the update during the School Board’s quarterly report date on January 26, 2017.

Fred Muscavitch motioned to ratify. Todd Hill seconded. Motion carried.

4. January 10, 2017 – approval to reschedule regular school board meeting to January 18, 2017

Rhiannon “RC” Metoxen motioned to ratify. Margaret Ellis seconded. Motion carried.

IV: **Tabled Business**

A: None

V: **Old Business / Follow-Up**

A: Standing Agenda Items

1. CIP / High School – Planning Department [moved up to first item on agenda]

2. Language Program – Language / Grants Departments –

Sheri Mousseau provided update; Flyer [add-on]

Melinda K. Danforth motioned to accept update and flyer as update. Fred Muscavitch seconded. Motion carried.

Discussion: Update requested from Priscilla Belisle and Tracy Williams regarding their training on February 1-2, 2017. Request to have Superintendent provide any history updates to School Board regarding previous concept updates/reports.

Margaret Ellis motioned to request School Board Administrative Assistant to find original motion and time line of events of actions of school board regarding the Language House program at O.N.S.S. and to provide an update at next regular School Board meeting. Rhiannon “RC” Metoxen seconded and 1 abstention. Motion carried.

3. Staff Recognition program – Update by Sheri Mousseau

School Board will be added to the recognition program.

Rhiannon “RC” Metoxen motioned to accept update. Margaret Ellis seconded. Motion carried.

4. Athletics – Update from Artley Skenandore

No update.

5. JOM Program – December meeting was cancelled

a. Minutes

b. Budget

January 2017 meeting was cancelled due to weather. JOM will hold a Spaghetti Dinner and Social during Parent/Teacher Conferences on January 26.

Melinda K. Danforth accepted update. Margaret Ellis seconded. Motion carried.

Discussion: Who is paying for Social? Is payment going to individuals or to the Long House? Nobody has requested a payment to go towards the Social this year; no payment will be made.

B: Follow-up

1. Youth Risk Behavior System (YRBS)

a. Subcommittee

The January 2017 meeting had been cancelled due to the weather and will be rescheduled.

2. Ramah Navajo meeting with Business Committee is January 12 from 10:00 – noon: F.Y.I. *Meeting had been cancelled according to a previous school board action on December 19, 2016. Discussion: Include an update in the School Board Quarterly Report to the B.C. that an update of the settlement money will be provided to them after a meeting with the Trust Committee, and this will be made available during the School Board report date on January 26, 2017.*
3. School Board retreat is scheduled Saturday, January 14 from 8 a.m. – noon: F.Y.I.
4. Edward Delgado KG Petition – F.Y.I.
Excerpt from 12/20/2016 B.C. meeting: *Superintendent will bring back a memo for the January 17th BC Work Session with requested statistics and information related to retention of kindergarteners.*
Sheri Mousseau provided update that the information had been completed and sent to Jo Ann House. The kindergarten retentions are lower than they appear.
5. Oath of Office date for new School Board member has been moved to January 11, 2017

VI: New Business

1. Updates to 2016 – 2017 School Calendar – Approval
 - a. Switched events on January 20 and 23 (January 20 is now a no-school day)
 - b. Added February mid-winter dates to calendar (school is in session)
 - c. Added June 9 High School Graduation date*Rhiannon "RC" Metoxen motioned to approve changes in calendar. Melinda K. Danforth seconded. Motion carried.*
2. 2017 New Quarterly reporting schedule to Oneida Business Committee – F.Y.I. will be forwarded to everyone today, 1/18/2017
3. Vision and Hearing Summary Data – FYI from Nurse Margaret
Fred Muscavitch accepted report. Rhiannon "RC" Metoxen seconded. Motion carried.
4. Approval of upcoming scheduled special meeting dates
 - a. January 28, 2017, 8:30 – noon at the Oneida Community Health Center w/Administration
 - b. February 10, 2017, noon – 4:00 p.m. at ONES main office conference room w/Attorney
 - c. February 18, 2017, 8:30 – noon at Oneida Community Health Center w/Administration
 - d. March 4, 2017, 8:30 – noon at the Radisson w/Administration and Attorney Joanne*Rhiannon "RC" Metoxen motioned to approve dates with corrections of February 10, 2017 being from noon until 4:00 p.m. and with the school board attorney. Fred Muscavitch seconded. Motion carried.*

VII: Reports

A: Superintendent's Report

Update on finding qualified applicants to fill vacant positions. CESA 7 is assisting with those applicants without proper certification. Items approved to order from Ramah Navajo settlement money have been ordered and some are already received.

Rhiannon "RC" Metoxen motioned to approve update. Fred Muscavitch seconded. Motion carried.

B: Administrative Staff Reports

1. Business Manager
2. K-8 Principal
 - a. Assistant Principal
 - b. Gifted and Talented

3. 9-12 School Principal
4. Special Education
5. Technology
6. FACE

School Board Google Chrome Book log-in has been emailed to School Board members. Technology Coordinator can hold a brief session of how to navigate program, if needed.

Fred Muscavitch accepted staff reports. Melinda K. Danforth seconded. Motion carried.

Rhiannon "RC" Metoxen motioned to move into executive session at 1:15 p.m. with the presence of Superintendent, Sheri Mousseau and Business Manager, Linda Jenkins. Melinda K. Danforth seconded. Motion carried.

VIII: Executive Session

1. Election of School Board Officers

Melinda K. Danforth motioned to sustain Debra J. Danforth as Chair; Fred Muscavitch as Vice Chair; and Rhiannon "RC" Metoxen as Secretary. Positions were accepted by delegates.

2. Food Service Employees

Business Manager, Linda Jenkins, provided power point handout of wage scales and options. Fred Muscavitch motioned to accept presentation. Melinda K. Danforth seconded. Motion carried.

Fred Muscavitch motioned to approve wage scale option on page 13. 2 approved, 1 abstained, 3 unapproved. Hand count vote completed. Motion failed.

Rhiannon "RC" Metoxen motioned to requested Business Manager to submit a revised wage scale to accommodate employees so they do not receive any less pay, and to submit to board members via an E-Poll. Fred Muscavitch seconded. Motion carried.

IX: Recess/Adjourn

Rhiannon "RC" Metoxen motioned to come out executive session at 1:45 p.m. Fred Muscavitch seconded. Motion carried.

Todd Hill motioned to adjourn at 2:00 p.m. Margaret seconded. Motion carried.

Respectfully submitted,



Rhiannon Metoxen
Secretary
Oneida Nation School Board

approved / corrected on 4-15-17
Date

Oneida Nation School Board
Special Meeting

Date: Saturday, January 28, 2017

Time: 8:30 a.m.

Place: Oneida Community Health Center Conference Room

PRESENT: Debbie J. Danforth, Fred Muscavitch, Margaret Ellis, Rhiannon “RC” Metoxen, Melinda K. Danforth [arrived at 9:00 a.m.], Shanna Torres [name added to minutes]

EXCUSED: Neset Skenandore, Todd Hill

OTHERS: Artley Skenandore, Yvette Peguero, Sheri Mousseau

TIME: 8:50 a.m.

- I:** Approval of Agenda – Review and update Education Law
- II:** Discussion: Topics to consider are the mission and vision for the school system. Language and culture should be considered in all areas and to look at innovating in all areas. Concerns are to be able to have the language and culture taught correctly, including pronunciation. Understand the difference between Responsibility vs Authority. It takes a lot of detailed explanation to understand 903.1(b); the Board of Education personnel will have a lot of responsibilities. What should the title be (Oneida Nation School Board will remain with same title). *Option – Education Council, who would be considered the custodians of the law.*
- III.** Additional departments/areas to include in draft - Cultural Heritage, Community Education Center (C.E.C), Language Program.
- IV.** Updates to 903.1 draft –
- a. Concept of the Purpose is good as-is.
 - b. Letter (c) should come before letter (b).
 - c. Sections recommended to be moved: (c) should be moved to Board of Education; D stays; E should be moved to Board of Education; F stays; G should be moved to the Adoption section.
 - d. Policy Section changes: #3-5 should be moved to the Board of Education; #7 should be moved to the Purpose; #8 should be moved to the Board of Education; #9 should be moved to the School System; #10 and #11 should be moved to Board of Education; delete #13.
 - e. Under Governance, pg 8: line 213 should all go under the Purpose
- V.** Subcommittee creation – Volunteers to be on Education Law Subcommittee in order to move the draft along and to ensure its accurateness: Fred Muscavitch, Artley Skenandore, Debbie J. Danforth, Sheri Mousseau, Yvette Peguero.
- VI.** Closing remarks/actions – Request to correct spelling errors in the title. School Board Administrative Asst. is requested to make colored changes and email to all School Board members.

Melinda K. Danforth motioned to have Jolene Hensberger go through the historical School Board Minutes to find any Action items that the School Board needs to follow-up on and to bring those back to the March 2017 regular meeting, including the orientation packet for new members. Rhiannon "RC" Metoxen seconded. Motion carried.

- VII.** Upcoming meetings/meetings to be scheduled –
 - a. Planning Dept on CIP for new high school – keep the 1/31/17 at 3:30 meeting at the Little Bear Development Center. Use 2/17/2017 or an earlier date as a back-up for unfinished items.
 - b. Education Law Subcommittee – meeting on 1/31/2017 from 1:30 – 3:00 at ONES
 - c. Trust Committee / School Board to discuss investment – Invite them to the regular school board meeting on 2/06/17.
 - d. Food Service Contract Proposal – Attorney Joanne Harmon Curry is currently working on another draft and Memo to Pat Garvey. An e-poll will be requested for approval when new draft is received.
 - e. CFO/Treasurer meeting – needs to be scheduled

- VIII.** Adjourn: Rhiannon "RC" Metoxen motioned to adjourn at 10:50 a.m. Melinda K. Danforth seconded. Motion carried.

Respectfully submitted,

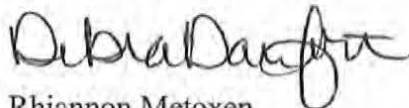

Rhiannon Metoxen
 Secretary
 Oneida Nation School Board

approved amended on 4-15-17
 Date

Oneida Nation School Board
Special Meeting

Date: Tuesday, January 31, 2017
Place: Little Bear Development Center

Time: 3:30 p.m.

PRESENT: Debbie J. Danforth, Fred Muscavitch, Margaret Ellis [arrived at 3:37 p.m.], Rhiannon "RC" Metoxen [arrived at 3:40 p.m.], Melinda K. Danforth, Todd Hill, Shanna Torres

EXCUSED: Neset Skenandore

OTHERS: Artley Skenandore, Linda Jenkins, Sheri Mousseau, Leanne Doxtater, Stacie Danforth, Ron Melchert

TIME: 3:30 p.m.

- I:** Agenda – Discuss C.I.P. project, concept paper, and project layout for a new High School
- II:** Discussion: Viewed 3-D project layout, reviewed hand-out Option B (large high school with no F/A/R component) for a new high school to fix approximately 300 students. The former Erickson Property appears to be the best location per the Planning Department. There are other facilities in this project. End projects are to bring the Oneida language and culture back to the community through buildings, landscape, and business. Priority is to complete an updated C.I.P. concept paper with accurate data. Funding and maintenance of new high school without using tribal contribution also discussed.
- III.** Closing remarks/actions –
- a. Planning Department would like to create a School Project Team, which includes members of the School Board with a request of participation from Sheri Mousseau and Artley Skenandore.
 - b. The School Board needs to be notified when the updated Concept Paper and data are completed and prior to it being placed on the Business Committee Agenda.
 - c. Updated C.I.P. concept paper and data to be presented to the School Board on or before scheduled meeting on 2/17/2017 at 3:30 p.m. at the Little Bear building.
- IV.** Adjourn: Melinda K. Danforth motioned to adjourn at 3:40 p.m. Margaret Ellis seconded. Motion carried.

Respectfully submitted,

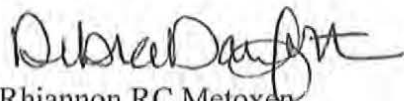

Rhiannon RC Metoxen
Secretary
Oneida Nation School Board

approved / corrected on 4-15-17
DATE

Oneida Nation School Board
Regular Meeting Minutes

Date: Monday, February 06, 2017

Time: 5:00 p.m.

Place: ONES Library

The Oneida Nation School Board is committed and accountable to students, parents, families, staff, and community members to provide regulatory oversight for a safe, positive, culturally diverse, holistic, learning atmosphere based on Onlayoté a'ka values. We will provide the expectations, resources, and educational opportunities to encourage students to be productive.

PRESENT: Debbie J. Danforth, Todd Hill, Shanna Torres [arrived at 5:15], Fred Muscavitch, Melinda K. Danforth

EXCUSED: Neset Skenandore, Rhiannon RC Metoxen, Margaret Ellis

OTHERS: Sheri Mousseau, Linda Jenkins, John Bestul, Susan White, Norbert Hill Jr., Carol Liggins, Jacqueline Diagle [left at 5:20], Artley Skenandore [left at 5:43]

CALL TO ORDER BY: Debbie J. Danforth

TIME: 5:15 p.m.

I: Approve Agenda

Melinda K. Danforth motioned to approve agenda with add-on's and to move the Trust and Enrollment presentation to first item on the agenda. Fred Muscavitch seconded. Motioned carried.

Fred Muscavitch motioned to go into executive session at 5:20 p.m. with the presence of Administration, Trust and Enrollment Committee, and Business Manager, Linda Jenkins. Todd Hill seconded. Motion carried.

Fred Muscavitch motioned to come out of executive session at 5:43 p.m. Todd Hill seconded. Motion carried.

II: Special Presentation

A: High School Graduates – None

III. Minutes

A: Regular Meeting – January 18, 2017

Fred Muscavitch motioned to approve minutes. Melinda K. Danforth seconded. Motion carried.

B: Special Meetings

1. January 13, 2017 – Meeting to review Employment Law and Education Law
Fred Muscavitch motioned to approve minutes. Todd Hill seconded. Motion carried.

2. January 14, 2017 – Education Law Retreat
Melinda K. Danforth motioned to approve minutes. Todd Hill seconded. Motion carried.

3. [add-on] January 28, 2017 – Meeting to work on Education Law
Fred Muscavitch motioned to approve minutes. Melinda K. Danforth seconded. Motion carried.

4. [add-on] January 31, 2017 – Meeting with the Planning Department
Melinda K. Danforth motioned to approve minutes. Shanna Torres seconded. Motion carried.

C: Ratification of Board Polls

1. January 20, 2017 – Approve revised Food Service Employee Wage Scale
Fred Muscavitch motioned to ratify board poll. Melinda K. Danforth seconded.

IV: Tabled BusinessA: None**V: Old Business / Follow-Up**A: Standing Agenda Items

1. CIP / High School – Planning Department
 - a. Meeting date and time
 - b. Hand-out of 1/28/15 denied plan due to being outdated
 - c. Binder of CIP documents
 - d. [add-on] CIP updated concept paper from 1/31/2017 meeting with Planning
 - e. [add-on] CIP updated concept paper from 2/02/2017

Melinda K. Danforth motioned to accept 2/02/17 updated draft as FYI. Todd Hill seconded. Motion carried. The next scheduled meeting to receive the Planning Department's update is on 2/17/17.

2. Language Program – Language / Grants Departments –
 - a. prior data of events update previously created by Cathy Bachhuber

Sheri Mousseau provided update. Fred Muscavitch motioned to accept update. Melinda K. Danforth seconded. Motioned carried.

3. Staff Recognition program – Update by Sheri Mousseau

Recognition will still occur in April and School Board will be included. Melinda K. Danforth motioned to accept update. Fred Muscavitch seconded. Motion carried.

4. Athletics – Update from Artley Skenandore [not present]

Sheri Mousseau provided update. Fred Muscavitch motioned to accept update. Melinda K Danforth seconded. Motion carried.

5. JOM Program – January 26th events scheduled were Spaghetti Dinner and Social

- a. Minutes – will be made available for next meeting
- b. Budget – will be made available for next meeting
- c. Next JOM meeting is scheduled on 2/23/2017

Sheri Mousseau provided update. Fred Muscavitch motioned to accept update. Todd Hill seconded. Motion carried.

B: Follow-up

1. Youth Risk Behavior System (YRBS)
 - a. Subcommittee – Artley Skenandore [not present]

A meeting was held on 2/06/17 with Joanne Ninham, Fred Muscavitch, Artley Skenandore, and Sheri Mousseau.

Melinda K. Danforth motioned to accept update. Todd Hill seconded. Motion carried.

2. Utilization of Ramah Navajo settlement money update to Business Committee –

- a. Memo or letter of update needs to be sent to B.C. after meeting with Trust Dept.

Fred motioned to accept update. Melinda K. Danforth seconded. Motion carried.

Discussion: Requesting School Board Admin. to develop a draft and send to Chair and Superintendent for review before sending to the Oneida Business Committee.

3. Ed Delgado Petition – Hand-out of information sent to Jo A. House and the B.C.
Melinda K. Danforth motioned to accept update. Todd Hill seconded. Motion carried.
4. Upcoming meetings –
 - a. February 10, 2017, noon – 4:00 p.m. at ONES main office conference room w/Attorney
 - b. [add-on] February 17, 2017, 3:30 p.m. – 4:30 p.m. at Little Bear Development Center
 - c. February 18, 2017, 8:30 – noon at Oneida Community Health Center w/Administration
 - d. March 4, 2017, 8:30 – noon at the Radisson w/Administration and Attorney Joanne
 - i. Submitted request to hold meeting in conference room at O.C. H.C.

VI: New Business –

1. [add-on] Oneida School Board Performance Assurance Audit
#15 bylaws – Debbie wants Joanne Harmon Curry to respond to this one due to the School Board’s autonomy.
When responses are received from Joanne H C, they will be forwarded to Board members.

VII: Reports

A: Superintendent’s Report

Melinda K. Danforth motioned to accept report. Shanna Torres seconded. Motion carried.

B: Administrative Staff Reports

1. Business Manager
2. K-8 Principal
 - a. Assistant Principal
 - b. Gifted and Talented
3. 9-12 School Principal
4. Special Education
5. Technology – Chrome Book overview and distribution
6. FACE

Melinda K. Danforth motioned to accept administrative staff reports. Todd Hill seconded. Motion carried.

C: Monthly School Calendar – F.Y.I. hand-out

VIII: Executive Session

Melinda K. Danforth motioned to go into executive session at 6:53 p.m. Fred Muscavitch seconded. Motion carried.

Melinda K. Danforth motioned to come out of executive session at 7:05 p.m. Fred Muscavitch seconded. Motion carried.

A. Food Service Employees Contract Proposal – Draft will be an add-on
Melinda K. Danforth motioned to remove the second paragraph of the Vehicle Policy on page five; update Oneida Tribe of Wisconsin throughout the document to Oneida Nation; and contemplate on proposing a contract for Food Service Director starting next school year. Todd Hill seconded. Motion carried.

B. [add-on] Trust and Enrollment Ramah Navajo settlement investment spreadsheet and Endowment Law hand-out
Melinda K. Danforth motioned to create a Trust and Enrollment Subcommittee – volunteers are Fred Muscavitch, Artley Skenandore, Linda Jenkins, and Sheri Mousseau. A meeting date is to be established to discuss investment options and whether a MOU or MOA is an option, and to bring this information back to the School Board in March 2017. Shanna Torres seconded. Motion carried.

IX: Recess/Adjourn

Melinda K. Danforth motioned to adjourn at 7:10 p.m. Todd Hill seconded. Motion carried.

Respectfully submitted

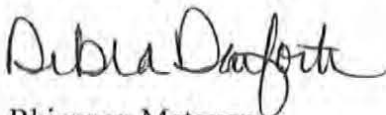

Rhiannon Metoxen
Secretary
Oneida Nation School Board

Approved/corrected
4-15-17
DATE

**Oneida Nation School Board
Retreat Minutes**

DATE: Friday, February 10, 2017
PLACE: ONES Admin Conference Room

TIME: 12:00 p.m.

The Oneida Nation School Board is committed and accountable to students, parents, families, staff, and community members to provide regulatory oversight for a safe, positive, culturally diverse, holistic, learning atmosphere based on On̄oyoté a'ka values. We will provide the expectations, resources, and educational opportunities to encourage students to be productive.

PRESENT: Todd Hill, Debbie Danforth [arrived at 12:11 p.m.], Melinda K. Danforth, Fred Muscavitch, Shanna Torres, Margaret Ellis [left at 3:15 p.m.]

EXCUSED: Neset Skenandore, Rhiannon RC Metoxen

OTHERS: School Board Attorney, Joanne Harmon Curry

CALL TO ORDER: Debbie Danforth

TIME: 12:15 p.m.

- I. Approval of Agenda
Motion by Fred Muscavitch to approve agenda with following changes – move III. to first item on the agenda; move II. 2. to second item on the agenda. Seconded by Shanna Torres. Motion carried.
- II. Old Business/Follow-Up
 1. Education Law review
Reviewed and made changes to sections 903.1-1 thru 903.4-21
 2. School Board Performance Audit
Items to be addressed were reviewed. A response to such items will be completed by Attorney Joanne Harmon Curry.
- III. E-Poll
 1. February 10, 2017 - Ratify approved e-poll to submit Garden Grant form
Motion by Melinda K. Danforth to ratify. Seconded by Todd Hill. Fred Muscavitch abstained. Motion carried.
- V. New Business
 - 1.
- IV. Recess/Adjourn
Motion by Melinda K. Danforth to adjourn at 3:25 p.m. Seconded by Todd Hill. Motion carried.

Respectfully submitted,

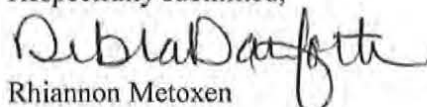

Rhiannon Metoxen
Secretary
Oneida Nation School Board

approved / corrected on 4-15-17
Date

**Oneida Nation School Board
Special Meeting Minutes**

DATE: Friday, February 17, 2017
PLACE: Little Bear Development Center

TIME: 3:30 p.m.

The Oneida Nation School Board is committed and accountable to students, parents, families, staff, and community members to provide regulatory oversight for a safe, positive, culturally diverse, holistic, learning atmosphere based on Onlayoté a'ka values. We will provide the expectations, resources, and educational opportunities to encourage students to be productive.

PRESENT: Melinda K. Danforth, Shanna Torres, Fred Muscavitch, Todd Hill, Rhiannon "RC" Metoxen, Debbie Danforth [arrived at 3:40]

EXCUSED: Margaret Ellis, Nese Skenandore

OTHERS: Leanne Doxtater [left at 3:50 p.m.], Sheri Mousseau, Linda Jenkins

CALL TO ORDER: Fred Muscavitch

TIME: 3:37 p.m.

- I. Approval of Agenda
- II. Old Business/Follow-Up
 1. Updated CIP / concept draft.
Rhiannon Metoxen motioned to accept the CIP Draft as presented with recommendations, and to have the updated draft brought back to the March school board meeting, and to potentially have it added to a B.C. Agenda in March.
- III. New Business
 1. FY 2017 Coordinated Tribal Assistance Solicitation Grant Resolution
Melinda K. Danforth motioned to approve resolution with recommended changes. Fred Muscavitch seconded. Motion carried.
 2. Memorandum of Intent to Issue Contracts and Explanation to ONSS Food Service Workers
Melinda K. Danforth motioned to approve Memorandum with changes and to be associated with the O.N.S.S. Food Service Employees' revised contracts. Fred Muscavitch seconded. Motion carried.
- IV. Recess/Adjourn
Rhiannon RC Metoxen motioned to adjourn at 4:30 p.m. Shanna Torres seconded. Motion carried.

Respectfully submitted,

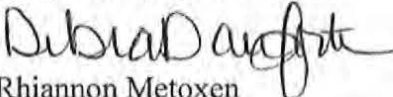

Rhiannon Metoxen
Secretary
Oneida Nation School Board

approved / corrected on 4-15-17
Date

**Oneida Nation School Board
Retreat Minutes**

DATE: Saturday, February 18, 2017
PLACE: Oneida Community Health Center

TIME: 8:30 a.m.

The Oneida Nation School Board is committed and accountable to students, parents, families, staff, and community members to provide regulatory oversight for a safe, positive, culturally diverse, holistic, learning atmosphere based on Onlayoté a'ka values. We will provide the expectations, resources, and educational opportunities to encourage students to be productive.

PRESENT: Debbie J. Danforth, Fred Muscavitch, Shanna Torres, Margaret Ellis, Melinda K. Danforth, Todd Hill

EXCUSED: Neset Skenandore, Rhiannon RC Metoxen

OTHERS: Sheri Mousseau, Artley Skenandore

CALL TO ORDER: Debbie J. Danforth

TIME: 8:36 a.m.

I. Approval of Agenda

II. Old Business/Follow-Up

1. Review and Update of Education Law

- *Send recommended changes to School Board Attorney to complete a Draft 3: Move Sections 903.5, 903.6, 903.7, 903.8, 903.9, and 903.10 to the Policy section.*
- *When completed, next meeting will be to go over updated draft with attorney to discuss and determine the functions of each entity, possibly outcomes, and what needs to exist in the future, in addition to when and how to meet with these entities.*
- *Draft 3 should be sent out to School Board members prior to March 4th Retreat.*
- *Artley Skenandore will provide a list of prospective entities.*
- *School Board Administrative Assistant will follow up with Joanne to find out if document needs to be sent to the Oneida Business Committee prior to General Tribal Council, and will create the March 4th meeting agenda.*
- *A time-line of completion of document can be established.*
- *Pot-luck for March 4th Retreat.*

IV. Recess/Adjourn

Meeting adjourned at 10:41 a.m. (no vote)

Respectfully submitted,

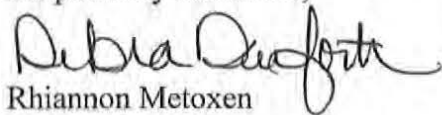

Rhiannon Metoxen

Secretary

Oneida Nation School Board

approved / corrected on

4-15-17

Date

**Oneida Nation School Board
Retreat Minutes**

DATE: Saturday, March 04, 2017

TIME: 8:30 a.m.

PLACE: Oneida Community Health Center

The Oneida Nation School Board is committed and accountable to students, parents, families, staff, and community members to provide regulatory oversight for a safe, positive, culturally diverse, holistic, learning atmosphere based on Onayoté a'ka values. We will provide the expectations, resources, and educational opportunities to encourage students to be productive.

PRESENT: Debbie J. Danforth, Fred Muscavitch, Melinda K. Danforth, Todd Hill, Shanna Torres, Margaret Ellis [arrived at 8:44 a.m.]

EXCUSED: Neset Skenandore, Rhiannon Metoxen

OTHERS: Joanne Harmon Curry (School Board Attorney), Sharon Mousseau, Art Skenandore, Yvette Peguero, Jolene Hensberger [recorder]

CALL TO ORDER: Debbie J. Danforth at 8:45 a.m.

OPENING: Art Skenandore

- I. Approval of Agenda
Melinda K. Danforth motioned to approve the agenda with the add-on discussion of the Food Service Employee Contract to be the first item.
- II. Food Service Employee Contract [add-on]
School Board Attorney, Joanne Harmon Curry, requested clarification of outcome if employees do not opt to sign contract, along with recommendations of language. Attorney requested copy of School's lay-off notice sent to Food Service Employees. Melinda K. Danforth motioned to approve Attorney's language recommendations and to revise the last sentence of the contract. Todd Hill seconded. Motion carried.
- III. Upcoming School Board meetings
 1. Monday, March 6 – Head count of members to be present [two members requested to be excused]
 2. Monday, April 3 – discussion about changing the date [two members requested to be excused]
Hand count. Fred Muscavitch motioned to keep date of March 6 and to reschedule April 3 to April 4 at 5:00 p.m. in the O.N.E.S. library. Margaret seconded. Motion carried.
Future meetings to be held at the Health Center: 1) 8:30 – noon, Saturday, March 25, 2017 with Principals; 2) 8:30 – noon, Saturday, April 15, 2017, with the School Board Attorney and Principals.
- IV. Old Business/Follow-Up
 1. Education Law
 - a) Memo of overview of the new Draft 3 Education Law with some explanation and comments
 - b) Proposed Education Law [red-lined revisions from 2/10/17 and 2/18/17 meetings]
 - c) Proposed Education Law [clean copy of revisions plus additional recommendations]
 - d) Letter from BIE re School Compliance with Federal Laws*Red-lined revised draft and clean version reviewed with additional changes and updates. Artley Skenandore will continue to work on list of educational entities to include in law. School Board Attorney will make updates discussed and email draft to School Board prior to next retreat.*
- VI. Recess/Adjourn
Fred Muscavitch motioned to adjourn at 11:34 a.m. Shanna Torres seconded. Motion carried.

Respectfully submitted,

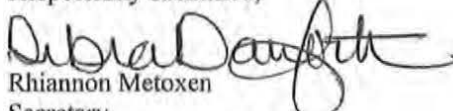
Rhiannon Metoxen
Secretary
Oneida Nation School Board

Approved/corrected
4-15-17
Date

Oneida Nation School Board
Regular Meeting Minutes

Date: Monday, March 06, 2017

Time: 5:00 p.m.

Place: ONES Library

The Oneida Nation School Board is committed and accountable to students, parents, families, staff, and community members to provide regulatory oversight for a safe, positive, culturally diverse, holistic, learning atmosphere based on Onlayoté a'ka values. We will provide the expectations, resources, and educational opportunities to encourage students to be productive.

PRESENT: Debbie J. Danforth, Fred Muscavitch, Todd Hill, Shanna Torres, Margaret Ellis

EXCUSED: Neset Skenandore, Rhiannon RC Metoxen

OTHERS: Fay LeMense, Sharon Mousseau, Art Skenandore, Linda Jenkins, Tracy Williams, Jessica Powless, Leander Danforth, Jackie Daigle Leanne Doxtater, Tracy Christensen, Yvette Peguero,

OPENING: Art Skenandore

CALL TO ORDER BY: Debbie Danforth

TIME: 5:00 p.m.

I: Approve Agenda

Motion by Fred Muscavitch to approve the agenda with the request to move the Language Program item to be first on the agenda, the Planning Department to be the second item on the agenda, include the attorney reviewed red-line version of MOA with the Trust and Enrollment Dept, and Contracts. Seconded by Todd Hill. Motion carried.

II: Special Presentation

A: High School Graduates – None

III. Minutes

A: Regular Meeting – February 06, 2017

Motion by Fred Muscavitch to approve the minutes. Seconded by Margaret Ellis. Motion carried.

B: Special Meetings

1. January 28, 2017 – Approve to amend [added Shanna Torres to Minutes]

Motion by Fred Muscavitch to approve the amended minutes. Seconded by Shanna Torres. Motion carried.

2. February 10, 2017 – Education Law Retreat

Motion by Fred Muscavitch to approve the minutes. Seconded by Todd Hill. Motion carried.

3. February 17, 2017 – CIP update w/Planning Department

Motion by Fred Muscavitch to approve the amended minutes. Seconded by Shanna Torres. Motion carried.

4. February 18, 2017 – Education Law Retreat

Motion by Fred Muscavitch to approve the amended minutes. Seconded by Shanna Torres. Motion carried.

5. March 4, 2017 – Education Law Retreat [add-on]

Motion by Fred Muscavitch to approve minutes. Seconded by Margaret Ellis. Motion carried.

C: Ratification of Board Polls – None

IV: Tabled Business

A: None

V: Old Business / Follow-Up

A: Standing Agenda Items

1. CIP / High School – Planning Department [moved to second item on agenda]

Leanne Doxtater provided update. The CIP is different than the CIP Concept Paper; the Concept Paper is just the concept of the project. By 2020, everything should be organized as well as a source of funding.

Discussion: School Board requests that to be notified when the Concept Paper is on the Business Committee agenda.

Motion by Fred Muscavitch to approve CIP Concept Paper. Seconded by Shanna Torres. Motion carried.

Motion by Margaret Ellis to accept update. Seconded by Todd Hill. Motion carried.

2. Language Program – Language / Grants Departments [moved to first item on agenda]
Tracy Williams provided update of attending the ANA Grant training in St. Paul, MN. An updated narrative is being worked on will be provided upon completion. Language program would like to either transfer under the Oneida Nation School Board or be aligned with instead of under Governmental Services. The Oneida Nation School System appears to be a better fit and they will have better access to the youth. The language program is most successful working with youth, and is in need of long term participants to meet benchmarks of curriculum.

Discussion: The line of authority needs to be followed before the School Board can take any action.

Motion by Margaret Ellis to direct School Board Administrative Assistant to schedule a meeting with the Business Committee to discuss the request from the Language House. Seconded by Todd Hill. Motion carried.

3. Staff Recognition program – Update by Sheri Mousseau

April date will be sent to School Board.

Motion by Margaret Ellis to accept the update. Seconded by Todd Hill. Motion carried.

4. Athletics – Update from Artley Skenandore

Winter sports of Basketball and Wrestling ended. Spring sports are Golf (boys and girls), Softball (girls); Track (boys and girls); Lacrosse (historically boys). The O.N.S.S. Athletic Department has a good percentage of student body participants.

Discussion: "Shout-out" was made to Boys' Basketball Coaches for including and allowing a student with a disability to shoot and score a basket during a game.

Motion by Margaret Ellis to accept update. Seconded by Todd Hill. Motion carried.

5. JOM Program –

- a. November 2016 Minutes
- b. February Agenda (No February Minutes) – Only (1) person present for meeting
- c. Budget – December 2016 and January 2017
- d. Next JOM meeting is scheduled on 03/23/2017

Motion by Margaret Ellis to accept update and budget report. Seconded by Todd Hill. Motion carried.

B: Follow-up

1. Youth Risk Behavior System (YRBS)

- a. Subcommittee – Update

Update by Art Skenandore. Currently waiting for set of questions from the Oneida Behavioral Health Department to combine with another set of questions. When received, the compiled questions will be presented to the School Board.

Motion by Fred Muscavitch to accept update. Seconded by Margaret Ellis. Motion carried.

2. Utilization of Ramah Navajo settlement money update to Business Committee –

- a. Memo or letter of update needs to be sent to B.C. after meeting with Trust Dept.
- b. Subcommittee – Update [MOA red-line attorney draft] [add-on]

Update provided by Art Skenandore.

Motion by Fred Muscavitch to adopt as final draft and approve to submit to Trust and Enrollment Department for review and approval. Seconded by Margaret Ellis. Motion carried.

3. Ed Delgado Petition – Power Point Presentation needs to be submitted to the B.C. for April or May 2017 meeting. Ed Delgado is currently in Arizona and is expected to return in April. The power point presentation should include the entire retention process, correct number of Kindergarten retentions, and any remedies to address absenteeism such as parent phone calls, home visits, etc., as well as percentage of failing KG students who transferred out.

Motion by Shanna Torres to accept update. Seconded by Margaret Ellis. Motion carried.

4. Oneida School Board Performance Assurance Audit

School Board Attorney is currently working on addressing this item. When response is completed, draft will be emailed for review. Debbie Danforth will request an extension on due date.

Update by Chair Debbie Danforth. A request for an extension of March 30 has been submitted with no response to date.

Motion by Fred Muscavitch to accept update. Seconded by Todd Hill. Motion carried.

5. List of Follow-up School Board items from previous minutes

Excerpt from 1/28/2017 Special School Board meeting: Melinda K. Danforth motioned to have Jolene Hensberger go through the historical School Board Minutes to find any Action items that the School Board

needs to follow-up on and to bring those back to the March 2017 regular meeting, including the orientation packet for new members. Rhiannon "RC" Metoxen seconded. Motion carried.

a. November 2, 2015 – Anti-bullying Retreat

Excerpt from minutes: Anti-bullying law legal opinion – Apache Danforth moved to schedule a retreat to review and update the Education Code to ensure that anti-bullying legislation is included. The retreat is to be scheduled within 60 days and includes the assistance of a facilitator. Rhiannon Metoxen seconded. Motion carried. Rhiannon Metoxen motioned to send communication to David Jordan and Fawn Billie as an update, and to include information on the PBIS program. Apache Danforth seconded. Motion carried.

Update by Chairperson, Debbie Danforth. Retreat was completed. Request Superintendent to confirm whether correspondence of PBIS update was sent to David Jordan and Fawn Billie.

b. December 7, 2015 – BIE Leadership Needs Assessment

Excerpt from minutes: BIE Leadership Needs Assessment – Melinda K. Danforth moved to complete the form and request for additional training for the School Board. Rhiannon Metoxen seconded. Motion carried.

Update by Superintendent, Sheri Mousseau. Oneida Nation School Board has been added to training list. Staff transitions are currently in place within BIE. Item to be removed from follow-up items.

c. May 2, 2016 – CIP High School [establish meeting with CFO, Tribal Treasurer, and School Board]

Excerpt from minutes: CIP – High School – Fred Muscavitch moved to set up a special meeting with the CFO, Tribal Treasurer and School Board to discuss funding. Rhiannon Metoxen seconded. Motion carried.

Include this item during the CIP Concept Paper meeting on March 22, 2017 and request the meeting after Concept Paper has been submitted.

d. May 2, 2016 – A.L.I.C.E. Safety presentation

Excerpt from minutes: A.L.I.C.E Safety presentation – OPD/Yvette – School Board will meet with the Business Committee in June or July to discuss implementation. Rhiannon Metoxen moves to approve the implementation of the ALICE program and to meet with the Business Committee to inform them of the implementation and to address safety concerns. Fred Muscavitch second. Motion carried.

Include this item during the CIP Concept Paper meeting on March 22, 2017. Request to email A.L.I.C.E. link to School Board members.

e. August 1, 2016 – CIP High School

Excerpt from minutes: CIP – High School – Rhiannon Metoxen moved to defer the CIP concept paper update until after the meeting with the Business Committee and to include a timeline of communication with planning. Neset Skenandore seconded. Motion carried. Neset Skenandore moved to accept the update. Melinda K. Danforth seconded. Motion carried.

Item completed last month and CIP Concept Paper has been approved at today's meeting. Remove from follow up items.

f. November 7, 2016 - School Flag / History of School Logo – FYI

Excerpt from minutes: Melinda K. Danforth motioned to accept the update on the logo history and to add item to January 14, 2017 Retreat Agenda with School Board attorney, and for administration to bring back options of a logo and seal. R.C. Metoxen seconded. Motion carried.

Art Skenandore provided history of logo at a prior meeting. Logo shall be kept as-is with no changes. Remove item.

g. November 7, 2016 – Staff Recognition Program

Excerpt from minutes: The Business Committee will be recognizing three (3) school staff for years of service during the 9:00 a.m. meeting on November 23, 2016. School Board members are encouraged to be present for the school staff recognition. R.C. Metoxen motioned to accept the update. Shanna Torres seconded. Motion carried.

School Board members recommended to attend recognitions. Updates received. Remove from follow up items.

VI: New Business – None

VII: Reports

A: Superintendent's Report

Motion by Margaret Ellis to accept report. Seconded by Todd Hill. Motion carried.

B: Administrative Staff Reports

1. Business Manager
2. K-8 Principal
 - a. Assistant Principal
 - b. Gifted and Talented
3. 9-12 School Principal
4. Special Education
5. Technology – Chrome Book overview and distribution
6. FACE

Motion by Fred Muscavitch to accept reports. Seconded by Todd Hill. Motion carried.

C: Monthly School Calendar – hand-out for FYI only

*Motion by Margaret Ellis to go into executive session at 6:17 p.m. Seconded by Todd Hill. Motion carried.
Present: Debbie Danforth, Fred Muscavitch, Melinda K. Danforth, Shanna Torres, Todd Hill
Others: Sheri Mousseau, Artley Skenandore, Yvette Peguero*

Motion by Margaret Ellis to come out of executive session at 6:38 p.m. Seconded by Todd Hill. Motion carried.

VIII: Executive Session

- A. Food Service Employees Contract – Draft will be an add-on
Excerpt from 2/06/2017 Regular School Board meeting: *Melinda K. Danforth motioned to remove the second paragraph of the Vehicle Policy on page five; update Oneida Tribe of Wisconsin throughout the document to Oneida Nation; and contemplate on proposing a contract for Food Service Director starting next school year. Todd Hill seconded. Motion carried.*
- a. Denial Letter from HRD [add-on] – Motion by Fred Muscavitch to forward denial letter received from HRD to School Board Attorney for review and recommendation.*
- B. Superintendent Contract [add-on] – *Motion by Todd Hill to approve with corrections to be made of changing the word “Tribe” to “Nation”. Seconded by Margaret Ellis. Motion carried.*
- C. Administration Contract [add-on] – *Motion by Todd Hill to approve with corrections to be made of changing the word “Tribe” to “Nation”. Seconded by Margaret Ellis. Motion carried.*
- D. Employee Contract [add-on] – *Motion by Todd Hill to approve with corrections to be made of changing the word “Tribe” to “Nation”. Seconded by Fred Muscavitch. Motion carried.*
- E. Notice to Renew Contract [add-on] – *Motion by Fred Muscavitch to approve with corrections to be made of changing the word “Tribe” to “Nation”. Seconded by Shanna Torres. Motion carried.*
- F. Ramah Navajo settlement investment with Trust and Enrollment Department
Excerpt from 2/06/2017 Regular School Board meeting: *Melinda K. Danforth motioned to create a Trust and Enrollment Subcommittee – volunteers are Fred Muscavitch, Artley Skenandore, Linda Jenkins, and Sheri Mousseau. A meeting date is to be established to discuss investment options and whether a MOU or MOA is an option, and to bring this information back to the School Board in March 2017. Shanna Torres seconded. Motion carried.*

Motion by Fred Muscavitch to adopt as final draft and approve to submit to Trust and Enrollment Department for review and approval. Seconded by Margaret Ellis. Motion carried. [see V. B. 2.] item above in minutes.

IX: ADJOURN *Motion by Todd Hill to adjourn at 6:45 p.m. Seconded by Shanna Torres. Motion carried.*

Respectfully submitted,

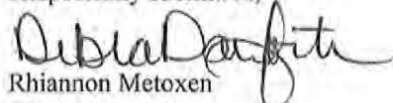

Rhiannon Metoxen
Secretary
Oneida Nation School Board

Corrected/approved

4-15-17
DATE

Oneida Nation School Board
Education Code Retreat

Date: Saturday, April 15, 2017

Time: 8:30 a.m.

Place: O.C.H.C.

The Oneida Nation School Board is committed and accountable to students, parents, families, staff, and community members to provide regulatory oversight for a safe, positive, culturally diverse, holistic, learning atmosphere based on Onlayoté a'ka values. We will provide the expectations, resources, and educational opportunities to encourage students to be productive.

PRESENT: Debbie J. Danforth, Shanna Torres, Fred Muscavitch, Melinda K Danforth, Margaret Ellis

EXCUSED: Neset Skenandore, Rhiannon Metoxen, Todd Hill

OTHERS: Jolene Hensberger [recorder]

OPENING: None

CALL TO ORDER BY: Debbie Danforth

TIME: 8:45 a.m.

I: Approve Agenda

Motion by Melinda K Danforth to approve the agenda but to only address the action items at this time; all other non-action items to be deferred to next Regular School Board meeting. Seconded by Shanna Torres. Motion carried.

II. Minutes

A: Regular Meeting – March 06, 2017 – *deferred to May 1, 2017 meeting*

B: Special Meetings

1. March 21, 2017 – Language House request meeting with Business Committee - *Deferred to May 1, 2017 meeting*

C: Ratification of Board Polls

1. 2017 – 2018 School Calendar

Motion by Melinda K. Danforth to ratify 2017 – 2018 School Calendar. Seconded by Margaret Ellis. Motion carried.

III: Tabled Business

A: None

IV: Old Business / Follow-Up

A: Standing Agenda Items

1. CIP / High School – Planning Department - *Deferred to May 1, 2017 meeting*

2. Language Program – Language House - *Deferred to May 1, 2017 meeting*

3. Staff Recognition program – Update by Sheri Mousseau
Reminder of recognition program provided by School Board Administrative Assistant

4. Athletics – Update by Artley Skenandore - *Deferred to May 1, 2017 meeting*

5. JOM Program – *Deferred to May 1, 2017 meeting*

a. March Minutes

b. Budget

c. Next JOM meeting is scheduled on 04/27/2017

B: Follow-up

1. Youth Risk Behavior System (YRBS) - *deferred to May 1, 2017 meeting*

[excerpt from March 4, 2017 Minutes] Currently waiting for set of questions from the Oneida Behavioral Health Department to combine with another set of questions. When received, the compiled questions will be presented to the School Board.

a. Subcommittee – Update - *Deferred to May 1, 2017 meeting*

2. Ed Delgado KG Petition – FYI - *Deferred to May 1, 2017 meeting*

Power Point Presentation will be submitted for the BC Work Session on April 18, 2017

3. Oneida School Board Performance Assurance Audit
 1. School Board Attorney Response [add-on]
 2. 2012 Legal Opinion on Whether Oneida Nation School Board Needs to Enact Bylaws [add-on]

[excerpt from March 6, 2017 Minutes] Update by Chair Debbie Danforth. A request for an extension of March 30 has been submitted with no response to date.

Motion by Melinda K. Danforth to approve School Board's legal response to Performance Audit and to schedule a plan of action to submit and to bring back to next meeting. Shanna Torres seconded. Motion carried.

4. List of Follow-up School Board items from previous minutes – **[UPDATES]** - *Deferred to May 1, 2017 meeting [excerpt from 1/28/2017 Special School Board Minutes] Melinda K. Danforth motioned to have Jolene Hensberger go through the historical School Board Minutes to find any Action items that the School Board needs to follow-up on and to bring those back to the March 2017 regular meeting, including the orientation packet for new members. Rhiannon "RC" Metoxen seconded. Motion carried.*
 - a. November 2, 2015 – **Anti-bullying Retreat and PBIS Plan & Documentation** - *Deferred to May 1, 2017 meeting*

[excerpt from March 6, 2017 Minutes] Update by Chairperson, Debbie Danforth. Retreat was completed. Request Superintendent to confirm whether correspondence of PBIS update was sent to David Jordan and Fawn Billie on 3/23/17.
Update: Documentation was emailed to Fawn Billie and David Jordan.

 - b. May 2, 2016 – **A.L.I.C.E. Safety presentation and link to website**
[excerpt from March 06, 2017 Minutes] Include this item during the CIP Concept Paper meeting on March 22, 2017. Request to email A.L.I.C.E. link to School Board members.
Update: A.L.I.C.E. link had been emailed on 3/09/17

Margaret Ellis requested to find out whether the School Board needs to participate.

[excerpt from March 6, 2017 Minutes] Update by Chairperson, Debbie Danforth. Retreat was completed. Request Superintendent to confirm whether correspondence of PBIS update was sent to David Jordan and Fawn Billie on 3/23/17.
Update: Documentation was emailed to Fawn Billie and David Jordan.

5. Education Law Updated Draft 4 –
 - a. Margaret Ellis will follow up with the Language House to determine and define a purposeful title for the Education Law and to bring back to the next meeting.
 - b. Request legal opinion of School Board Attorney whether the Definition of 'Board of Education' in line 117, page 5 of Draft 4 needs to legally be there – if not, it should be removed.
 - c. Insert word 'tribal' after the word 'nine' in line 204 as well as 18 years of age or older
 - d. Insert period after word 'large' in line 206.
 - e. Remove the word 'and' at the end of line 218
 - f. Remove or clarify word 'excepted' and change to 'exempted' in line 237
 - g. Insert 'the' in front of the word 'Education' in line 246
 - h. Remove 'in lieu of' in line 259
 - i. Change word 'shall' to 'may' in line 260

VI: New Business – none

VII: Reports

A: Superintendent's Report – Deferred to May 1, 2017 meeting

B: Administrative Staff Reports - Deferred to May 1, 2017 meeting

1. Business Manager
2. K-8 Principal
 - a. Assistant Principal
 - b. Gifted and Talented

3. 9-12 School Principal
4. Special Education
5. Technology – Chrome Book overview and distribution
6. FACE

C. Monthly School Calendar – hand-out for FYI only - *Deferred to May 1, 2017 meeting*

VIII: Executive Session

A. Food Service Employee Contract

1. School Board Attorney Response to Denial Letter from HRD [add-on]
[excerpt from March 06, 2017 Minutes] Motion by Fred Muscavitch to forward denial letter received from HRD to School Board Attorney for review and recommendation.

Motion by Margaret Ellis to approve legal opinion of School Board Attorney and to put onto BC Agenda with any back-up documentation. Seconded by Shanna Torres. Melinda K. Danforth abstained. Motion carried.

B. Ramah Navajo settlement investment with Trust and Enrollment Department – *Deferred to May 1, 2017 meeting*

1. Subcommittee – Review and approval of Trust Enrollment Committee Revised MOA
[excerpt from March 06, 2017 Minutes] Motion by Fred Muscavitch to adopt as final draft and approved to submit to Trust and Enrollment Department for review and approval. Seconded by Margaret Ellis. Motion carried.

- i. MOA red-line T/E Attorney Revised Draft
- ii. T/E Attorney Legal Review Memo of MOA Final Approval
- iii. Endowments Law and Resolution

2. Investment questions RE projected outflows - *Deferred to May 1, 2017 meeting*

3. Memo or letter of update needs to be sent to B.C. after meeting with Trust Enrollment Committee – FYI
[finalization of investment plan is currently being worked on by Trust Enrollment Committee and then meeting and letter will be completed]

Deferred to May 1, 2017 meeting

C. Request to extend L.T.E. Staff Positions [add-on]

1. High School – Ohuntsya kekha Kanunya? Shuha Teacher L.T.E. position
2. High School – Language Arts L.T.E. position
3. Elementary School – Elementary Teacher L.T.E. position

Motion by Melinda K. Danforth to approve extension of L.T.E. positions. Seconded by Shanna Torres. Motion carried.

D. Request to Post Vacant Positions [add-on]

1. Elementary School – Student Facilitator
2. High School – Science Teacher

Motion by Melinda K. Danforth to approve to post vacant positions. Seconded by Shanna Torres. Motion carried.

E. Signed School Board Resignation Letter

Motion by Margaret Ellis to accept signed resignation letter. Seconded by Shanna Torres. Motion carried.

IX: ADJOURN

*Motion to adjourn – no vote
 [adjourned at 10:18 a.m.]*

Oneida Business Committee Agenda Request

1. Meeting Date Requested: 04 / 27 / 17

2. General Information:

Session: Open Executive - See instructions for the applicable laws, then choose one:

Agenda Header:

Accept as Information only

Action - please describe:

Motion to accept the FY17 2nd Quarter Report

3. Supporting Materials

Report Resolution Contract

Other:

1.

3.

2.

4.

Business Committee signature required

4. Budget Information

Budgeted - Tribal Contribution

Budgeted - Grant Funded

Unbudgeted

5. Submission

Authorized Sponsor / Liaison:

Primary Requestor/Submitter:
Your Name, Title / Dept. or Tribal Member

Additional Requestor: _____
Name, Title / Dept.

Additional Requestor: _____
Name, Title / Dept.

Oneida Business Committee Agenda Request

6. Cover Memo:

Describe the purpose, background/history, and action requested:

To update the Business Committee on the performance of OAHC d/b/a Radisson Hotel & Conference Center Green Bay and Three Clans Airport d/b/a Wingate by Wyndham for the 2nd Quarter of FY17.

Request a motion to accept the OAHC 2nd Quarter Report for FY17.

- 1) Save a copy of this form for your records.
- 2) Print this form as a *.pdf *OR* print and scan this form in as *.pdf.
- 3) E-mail this form and all supporting materials in a **SINGLE** *.pdf file to: BC_Agenda_Requests@oneidanation.org

Oneida Airport Hotel Corporation
Radisson Hotel & Conference Center
Quarterly Report
For the quarter ended: March 31, 2017

Narrative Section

Business practice, market overview, place within market:

- STR report unavailable to show index variances YOY at time this report due
- Q2 Actual Budget numbers show YOY variance in Occupancy up 1.4%, ADR up YOY by \$.25 therefore showing Revenues up YOY by \$28,579
- Banquet and Catering Q1 Actual Budget numbers show YOY variance up by \$25,923
- Sales team attended American Bus Association marketplace, attended Chicago Sports and Travel Show w/ Oneida Tourism, attended and hosted Circle Wisconsin Annual Midwest Marketplace meeting in March. The sales team continues to network at events including Chamber Networking breakfasts monthly; BNI meetings weekly; Current luncheons/events monthly; Management Women events monthly; MPI event Quarterly; WSAE event quarterly; WBTA event quarterly – to gain leverage for the Radisson in the Green Bay market.

Competitive analysis:

- Casino food outlets continue to be a source of competition for F&B revenue
- KI Expansion a source of competition for large convention groups

Strategies for improved value:

- Developed packaging in Corporate/Association Meetings, Tour & Travel, Wedding, Travel Agents and Transient markets to gain short term bookings for need months
- Working with Radisson Corporate in all Sales markets to gain leverage and recognition
- Working with Aimbridge Regional properties to gain leverage and recognition
- Working closely with Green Bay CVB in all Sales markets to keep top of mind and participate in all sales initiatives

Material changes or developments in market/business:

- Appleton will be adding a Convention Center on land near the Radisson Appleton; this will add 33,000 square feet of meeting space, groundbreaking end of Sept 2016 – due to open September 2017
- Radisson Appleton will undergo full renovation – in our STR comp set
- Holiday Inn Appleton due to change to a Marriott product – in our STR comp set

Market growth:

- Northland Hotel started construction on 140 room hotel downtown to compliment the KI Convention Center expansion, unknown opening date
- Residence Inn 100 room property opened end of November 2016
- 4 Star Lodge Kohler property being built on Packer property near the stadium with 200 rooms – due to open July 2017
- Home 2 Suites to be built on Holmgren Way across from Grainger – ground breaking April 4th
- TBD property online to be built downtown on Broadway near The Cannery

Pending legal action:

- Nothing at the moment

Oneida Airport Hotel Corporation
Three Clans Airport, LLC
Quarterly Report
For the quarter ended: March 31, 2017

Business practice, market overview, place within market:

- The Wingate continues to focus growing rate over occupancy for the second quarter. The Wingate was able to grow rate by 12.7% and lost -9.73% in occupancy.
- The Wingate averaged a 53.6% occupancy for the second quarter.

Competitive analysis:

- The competitors ran a REVPAR of \$64.26 to Wingate's \$41.08 for the second quarter.
- The competitive set had an occupancy of 63.6% to the Wingate's 53.6%.

Strategies for improved value:

- The Wingate is focused on growing rate for the fiscal year.
- The Wingate's strategy is to yield rates sooner especially on high demand dates and to offer less heavily discounted rates on slow dates.
- The Wingate continues to use all 3rd party booking channels to increase bookings on low demand dates but is not using opaque rates as often and has increased the opaque to focus on its growing rate strategy.
- The Radisson Sales team continues to cross sell the hotel. The Radisson sales team uses the Wingate to sell to large convention groups as an overflow property.
- The Radisson and the Wingate have gone out together on spring sales calls cross selling both properties.

Material changes or developments in market/business:

- The Wingate continues to see increases in the corporate business traveler and is starting to see the corporate business traveler using travel agents again while shying away from the third party websites.
- We also were able to negotiate rates with some new local companies to add to the Wingate's preferred list.
- The Wingate lost its airline crew rooms starting in January. The airlines renegotiated the companies that chartered the major airlines into Green Bay and the crew that was currently housed at the Wingate did not win the bid. Should the crew come back to Green Bay, Wingate would be the host hotel. The Wingate has already sent RFP's and is trying to negotiate with the new crew, however the

airline has a strong connection to Hyatt properties and that is where they are currently staying.

Market growth:

- Revenues for the first quarter were \$29,6168 which were down from prior year by -\$3,562.00

Pending legal action:

- Nothing at the moment

Oneida Business Committee Agenda Request

1. Meeting Date Requested: 04 / 27 / 17

2. General Information:

Session: Open Executive - See instructions for the applicable laws, then choose one:

Agenda Header:

Accept as Information only

Action - please describe:

Motion to accept the OGE 2nd Quarter Report for FY2017

3. Supporting Materials

Report Resolution Contract

Other:

1.

3.

2.

4.

Business Committee signature required

4. Budget Information

Budgeted - Tribal Contribution Budgeted - Grant Funded Unbudgeted

5. Submission

Authorized Sponsor / Liaison:

Primary Requestor/Submitter:
Your Name, Title / Dept. or Tribal Member

Additional Requestor: _____
Name, Title / Dept.

Additional Requestor: _____
Name, Title / Dept.

Oneida Business Committee Agenda Request

6. Cover Memo:

Describe the purpose, background/history, and action requested:

To update the Oneida Business Committee on the performance of Oneida Golf Enterprise d/b/a Thornberry Creek at Oneida for the 2nd Quarter of FY2017.

Request a motion to accept the OGE 2nd Quarter Report for FY2017.

1) Save a copy of this form for your records.

2) Print this form as a *.pdf *OR* print and scan this form in as *.pdf.

3) E-mail this form and all supporting materials in a **SINGLE** *.pdf file to: BC_Agenda_Requests@oneidanation.org

Oneida Golf Enterprise Corporation**Fiscal year-To-Date Reporting for period Ending:****March, 2017**

The Oneida Golf Enterprise Corporation (OGEC) is a corporation of the Oneida Nation established to oversee and manage the business known as Thornberry Creek at Oneida.

Narrative Report**Business Practice, Market Overview, Place Within Market:**

- Thornberry Creek at Oneida (TCO) is a 27 hole premier golf course settled in a rural, prestigious housing development on the Oneida reservation.
- TCO is the Official Golf Course of the Green Bay Packers.
- TCO Legends Course was ranked #10 in the state by *GolfAdvisor* in 2016.
- TCO along with the Radisson, Wingate and Casino was ranked “Best Golf and Casino Resorts” in 2016 by *Golf Vacation Insider*.
- TCO Legends Course was ranked “Best of the Bay” 2016 best golf course by *Green Bay Press Gazette*.
- TCO is considered a leader in charitable golf event hosting and a leading choice for future brides.
- Thornberry Creek at Oneida has 7,000 square feet of flexible banquet space with large windows and spectacular views. This space will accommodate 300 guests at round tables. We also feature a porch room that accommodates up to 40 people. Included in this space is the Cupola available for smaller wedding ceremonies and intimate gatherings.
- Thornberry Creek at Oneida also offers a full range of conference equipment and amenities for the corporate client.
- TCO hosted 55 special events in the first quarter for a total of 55 special events in the FY 2017.
- TCO hosted 5 golf events in the first quarter with 3 Stay and plays in October.

Competitive Analysis:**GOLF**

- Competitive analysis is scheduled to be completed in the 3rd and 4th quarters.

Strategies for Improved Value:

- We continue to cobrand the Thornberry Creek LPGA Classic, Thornberry Creek at Oneida and the Oneida Nation including TV commercials, social media, print with advertising starting before the holidays. We will see another major push 6 to 8 weeks prior to the event. All of our print ads and social media are cobranded to benefit the Oneida Nation, Thornberry Creek at Oneida and the Thornberry Creek LPGA Classic.
- Ads have been placed in the *Packer Gameday* publication as well as the *Wisconsin Badger Yearbook* and the *Milwaukee Brewers Game Day Program*; the expected circulation of these publications will be in excess of 1 million
- TCO continues to maximize opportunities with golf outings, weddings and special events throughout the summer months.
- Our brand image continues to be elevated as we're seen and heard across all the major networks: FOX, CBS, NBC and WIXX.
- We now have a full year working under our new operating system so we are able to compare historical data very efficiently.
- We had a very successful trade show season selling out of fringe benefit cards again, this year at a higher price. We were also promoting the Thornberry Creek LPGA classic and our stay and plays and had great interest and feed back.
- TCO continues to be a major supporter in donations and giving within the community.

Material Changes or Developments in Market/Business:

- OTIE is actively working to complete the basement renovation; OTIE has been a pleasure to work with thus far. We are now seeing material changes with drywall up and painted, partitions and hardware is up in the locker rooms, and the bar is completed and very close to being functional. The area is expected to be complete by the beginning of June giving us plenty of time before the LPGA. We are already planning to utilize the space for golf outings and other events to generate revenue that is lost due to the upstairs being sold out for weddings or golf outings.
- TCO is in the middle of an aggressive onboarding process of employees. The quality of candidates still proves difficult in the market due to compensation packages and an extremely low unemployment rate. Although we were concerned about the quality and quantity of applicants throughout the spring our extended efforts in employee recruiting prove to pay off in the process. We are very comfortable with the staff we have hired thus far in all departments except for the kitchen where there is a lack of talent and applicants.
- We continue to create alignment in our branding efforts in all marketing campaigns and print materials onsite; this process will continue for the next few years.
- The Pub continues to struggle outside of the golfing season and the expectation of growth is minimal unless major changes are made to the concept and product offered.
- Over the winter months we did lose our Executive Chef Ashley Nero, who moved on to pursue a different opportunity in the area. We also separated our relationship with our Food and Beverage Director, Zach Knight. Since then, we have posted both position; we hired

from within promoting Kateri Danforth to Chef and we are still evaluating the F and B Director position.

Market Growth:

- Our social media presence continues to grow, up 3% in the 2nd quarter of FY2017 and up 23% from beginning of FY2016.
- Although revenues are up to budget and to prior year numbers so are expenses; some due to increased service efforts and operational costs from equipment breaking or needing to be replaced and preparation for the Thornberry Creek LPGA Classic.
- Pass holder sales continue to grow year over year; up 7% from FY2016.
- Weddings are up 33% in the 2nd quarter and we are projected to have 40 weddings in FY 2017 and they are still booking! Our wedding business is up 30% for FY 2017 from prior year, accounting for dates that are booked with deposits.
- We have sold out all Saturdays in 2017 from mid-April to October except for 3 weekends and beginning to book multiple wedding weekends. With the addition of the practice tee and basement renovations we will be able to offer outdoor ceremonies in 2017 and beyond thus creating additional revenue to the facility.

Pending Legal Action:

- No litigation pending.

Executive Summary

- In 1st quarter of FY 2017 our last round of golf we did was November 19th, approximately 3 weeks earlier than prior year. Despite having issues with the weather this year green fees are up \$26K over prior year and golf as a whole is up \$28k over budget. Golf grounds payroll and expenses are over budget due to demand and preparation for LPGA. F and B is up \$39k to prior year mainly due to pre-booked business which is more profitable while the pub business is down.
- Locker room and basement renovations will be complete this spring and will add value to pass holders and additional revenue to the facility for golf outings, weddings and other corporate events.
- TCO continues to see revenue growth but the overall team at TCO continues to change due to business and personal reasons. We are very close to deciding on the management team for the 2017 season and are excited about who we have on board for this very important year.
- Wages and total compensation continue to be reviewed due to the lack of potential employees in the marketplace
- TCO continues to venture down avenues for added growth of loyalty and revenues

Quarterly Financial Summary Attached

Oneida Business Committee Agenda Request

1. Meeting Date Requested: 4 / 27 / 17

2. General Information:

Session: Open Executive - See instructions for the applicable laws, then choose one:

[Empty text box]

Agenda Header: Reports

Accept as Information only

Action - please describe:

[Large empty text box for description]

3. Supporting Materials

Report Resolution Contract

Other:

1. Quarterly Report from Bay Bank for Open Session

3. [Empty text box]

2. [Empty text box]

4. [Empty text box]

Business Committee signature required

4. Budget Information

Budgeted - Tribal Contribution Budgeted - Grant Funded Unbudgeted

5. Submission

Authorized Sponsor / Liaison: Cristina Danforth, Tribal Chairwoman

Primary Requestor/Submitter: Jeff Bowman, President, Bay Bank
Your Name, Title / Dept. or Tribal Member

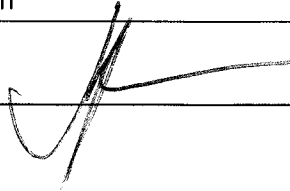

Additional Requestor: _____
Name, Title / Dept.

Additional Requestor: _____
Name, Title / Dept.

Oneida Business Committee Agenda Request

6. Cover Memo:

Describe the purpose, background/history, and action requested:

Bay Bank is presenting its quarterly corporate report to the BC in Open Session. Management of Bay Bank will provide a summary of the Bank's financial results for the quarter ended 3/31/17.

- 1) Save a copy of this form for your records.
- 2) Print this form as a *.pdf *OR* print and scan this form in as *.pdf.
- 3) E-mail this form and all supporting materials in a **SINGLE** *.pdf file to: BC_Agenda_Requests@oneidanation.org

Bay Bank
QUARTERLY REPORT

Quarter ended March 31, 2017

A. BAY BANK

Submitted by: Jeff Bowman, Board Member
Directors: Nathaniel King, Fern Orie, Bob Jossie
Jeff Bowman, Pete King, Elaine Skenandore-Cornelius

Oneida Business Committee Contact: Tina Danforth

B. MINUTES

None Submitted

ACTION TAKEN

No Tribal Policy change.

D. FINANCIAL

Note that various financial reports

December 31, 2017 is Bay Bank's fiscal year end.

E. SPECIAL EVENTS AND TRAVEL

None

F. PERSONAL COMMENTS

Bay Bank account numbers as of March 31, 2017:

1,168	Checking Accounts
372	Business Checking Accounts
70	Money Market Accounts

1,596	Savings Accounts
381	Certificates of Deposit
90	Commercial Real Estate Loans
819	Residential Real Estate Loans
171	Business Loans
574	Consumer Loans
37	Oneida Small Business 2000 Loan Program Loans

The Oneida Small Business Loan Program 2000 that is administered by Bay Bank started on May 1, 2002. As of this date over \$ 11.7 million in new loans have been made to over 126 new or growing Oneida tribal member owned businesses.

The Section 184 mortgage loans serviced under FHLB MPF program totaled \$60.6 million at March 31, 2017. There are 506 loans in the program currently.

G. GOALS AND OBJECTIVES

2016 GOALS:

GOAL A: Bay Bank will strive to attain a minimum 0.50% Return on Assets for the year ending December 31, 2017. Return on Assets (ROA) is a common measurement of a bank’s profitability. This ratio informs you how well the bank is managing and investing the bank’s assets.

2017 ROA Goal	2017 YTD ROA Actual	2017 Peer Group Average
0.50 %	0.74%	0.82%

GOAL B: Bay Bank will strive to attain a minimum 6.00 % Return on Equity for the year ending December 31, 2017. Return on Equity (ROE) is the measurement of how well the bank is performing for its stockholder.

2017 ROE Goal	2017 YTD ROE Actual	2016 Peer Group Average
6.00 %	5.16 %	6.88 %

Bay Bank had budgeted total loans for the quarter ended March 31, 2017 in the amount of \$ 51.6 million. Total loans at March 31, 2017 were \$ 55.5 million or \$ 3.9 million more than projected. Loans increased \$ 3.6 million over the 12-month period ended March 31, 2017.

Bay Bank had budgeted total deposits for the quarter ended March 31, 2017 in the amount of \$ 70.6 million. Total deposits at March 31, 2017 were \$ 69.5 million or \$ 1.1 million less than projected balances. Deposits increased \$ 5.1 million for the past twelve months, the result of increase in transaction and savings accounts offset to a lesser degree by a decrease in time deposits.

H.

MEETINGS

Monthly meeting on the third Thursday of each month. Well attended.

Oneida Business Committee Agenda Request

1. Meeting Date Requested: 4 / 27 / 17

2. General Information:

Session: Open Executive - See instructions for the applicable laws, then choose one:

Agenda Header:

Accept as Information only

Action - please describe:

Business Committee approval of report

3. Supporting Materials

Report Resolution Contract

Other:

1.

3.

2.

4.

Business Committee signature required

4. Budget Information

Budgeted - Tribal Contribution Budgeted - Grant Funded Unbudgeted

5. Submission

Authorized Sponsor / Liaison:

Primary Requestor: Jacquelyn Zalim, OESC Chairwoman of the Board
Your Name, Title / Dept. or Tribal Member

Additional Requestor: _____
Name, Title / Dept.

Additional Requestor: _____
Name, Title / Dept.

Oneida Business Committee Agenda Request

6. Cover Memo:

Describe the purpose, background/history, and action requested:

Corporate reporting requirement - Business Committee approval of report

- 1) Save a copy of this form for your records.
- 2) Print this form as a *.pdf *OR* print and scan this form in as *.pdf.
- 3) E-mail this form and all supporting materials in a **SINGLE** *.pdf file to: BC_Agenda_Requests@oneidanation.org

Oneida ESC Group, LLC

2nd Quarter Report – FY 2017

April 13, 2017

OESC Board of Managers:

Jacquelyn Zalim, Chair

John L. Breuninger

Leslie Wheelock

Oneida ESC Group, LLC (OESC), formed in 2012, is a holding company overseeing a portfolio of Limited Liability Companies competing in the environmental remediation, design, engineering and construction management industries. The sole member is the Oneida Nation.

OESC provides general management and administrative functions, including accounting and contracting management, human resource management, IT support, overall management, and marketing to its wholly owned subsidiaries.

Narrative Report

a. Explanation of the core of the Corporation's business practices and market overview

OESC's revenue is derived from the subsidiaries that operate in the Small Business Administration Business Development Markets primarily as 8a and Small Business designated companies.

OESC and its subsidiaries are a highly technical organization providing research /investigation, design, engineering and project management. OESC operates in five core services:

- Environmental services – Assessment, investigation, design, testing and monitoring
- Remediation – Action Planning, project management, extraction of contaminated materials.
- Construction and demolition – Repair, service, abatement, renovation and new.
- Engineering Services – Design and project managements for sites and site design, structural, mechanical, roads, bridges and water systems.
- Munitions response services – Investigation and remediation of munitions and ordinances.

Mission Support Services (MS2) – 8(a) Graduation date is 3/15/2022.

MS2 is focused on construction management contracts. Core competencies will include construction management services, New and renovated structures, HVAC systems and controls Utility systems - water, sewer, gas, electrical, Electrical power generators, transformers, and distribution, Communication and security systems, Interior remodeling, upgrades focused on the federal market with supplemental markets includes commercial and tribal construction projects.

Sustainment & Restoration Services (SRS) – 8(a) Graduation date is 2/18/2023.

SRS core competencies include facility investigations, corrective measures design/implementation, remedial designs/remedial actions, including characterization, assessment, and cleanup, Wetlands assessment and wetlands restoration design, Brownfields – Phase I & II ESAs, Technical Enforcement Support Facility and asset inventory, evaluation, and assessment Engineering design for site development, utility systems, and facilities Engineering design for wastewater treatment and sewerage systems.

Oneida Total Integrated Enterprises (OTIE) - 8(a) Graduation date is 4/4/2017.

As part of the overall strategic plan for continued growth, and the resolutions from 2013, OTIE was moved under OESC as of January 1, 2017. OTIE will begin to be included in the OESC 3rd quarter report.

b. Explanation of the Corporation's current place within the market

OESC operates in a fiercely competitive and expanding market. An abundance of Architecture / Engineering / Construction (AEC) firms provide similar services offered by OESC. Competitive factors for our success include performance reputation, network, price, geographic location, and availability of technically skilled personnel (flexibility).

The following data is from Deltek, a leading global provider of enterprise software and information solutions for government contractors, professional services firms and other project-and people-based businesses. Three of the top five federal spending agencies awarding non-competitive contracts are OESC customers.

c. Explanation of the outlines of strategies by the Corporation for improved value in the market

Our focus in the marketplace includes long-term, high-dollar contracts as a prime contractor, Low Risk Contracts – contracts OESC has a vast experience in executing successfully, capturing market share through performance and networking the family of companies and recruiting and retaining key employees.

d. Explanation of the Corporation's relative performance vs. competitors and identification of key competitors within the market

Our competitors include: Small Businesses, Alaskan Native Corporations (ANCs); Native American Owned, tribally-owned small businesses; and Native Hawaiian Organizations (NHOs). Each of these businesses is treated in a category of small business that may be awarded prime contracts without competition. OESC subsidiaries also compete against other 8(a) firms for set-aside acquisitions, including small businesses that are categorized as Woman-Owned, HUB Zone, Service Disabled Veteran Owned small business, and others. Finally, OESC competes in the full and open markets without restrictions.

e. Explanation of any material changes or developments in the market or nature of business the Corporation is primarily engaged in since the last reporting period

A regulatory change by SBA in 2016 increased the small business size standard in our primary NAICS code (562910) from 500 employees to 750 employees, a 50% increase.

Within small business circles, OESC subsidiaries remain sturdy competitors, but this regulatory change allowed a few larger, robust competitors like Conti, Versar and Parametrix.

Additionally, SBA adjusted the long-standing Mentor-Protégé Program (MPP) regulations to permit a small business of any category (Woman Owned small business, Veteran Owned

small business, HUB Zone, etc.) to establish an MPP with a large business. The impact of this change is that the approved MPP firms may submit a Joint Venture bid on a federal acquisition and compete against other joint or individual small businesses. Also, the agency has accelerated the review/approval process for MPP application, which is a change from the ordinarily long waiting period for small business and large business partners' applications.

f. Identification of the primary goals and targets of the Corporation and progress made towards accomplishment of the same

Opportunities continue to exist in geographies where OTIE, MS2, or SRS key personnel have successful past performance, and where personnel involved in such projects have established strong relationships with teaming partners and clients in those locations.

Downstream opportunities continue to emerge based on MS2 project performance and combined efforts of OTIE and MS2's marketing and sales efforts. Target clients continue to include Vandenberg AFB, NAVFAC SW, NAVFAC SE, NAVFAC Great Lakes, and NAS Pensacola.

Additional new target clients include Naval Base Ventura County, USACE Jacksonville, the US Army Joint Munitions Command (JMC), Edwards AFB, the Air Force Civil Engineering Center (AFCEC).

With SRS' recently awarded work, SRS target clients include EPA Region V and Naval Station Great Lakes. Additional new targets include USACE LA District, EPA Region VI and USACE Tulsa.

OTIE is supporting MS2 and SRS on many marketing and proposal efforts. MS2 and SRS have been introduced by OTIE to many potential government clients, and as a result, more opportunities are within reach so that they can recruit more capable people to support each federal agency's mission as well as increase their technical capabilities. The following is the assistance that OTIE has provided to MS2 and SRS:

- MS2 and SRS have performed some projects as a subcontractor to OTIE.
- MS2 has submitted proposals and has been awarded projects which have sustained staff at Vandenberg AFB to date and additional work is expected.
- OTIE's senior managers continue to introduce MS2 and SRS to different federal facilities in different states and continue to help M2 and SRS pursue several contract opportunities.

MS2 has been awarded contracts by the following clients: NAVFAC SE (Naval Station Pensacola), NAVFAC Mid-Atlantic (Great Lakes Naval Station), NAVFAC SW (Naval Base Ventura County), Army Contracting Command (Joint Munitions Command), USACE Omaha, USACE Albuquerque, Edwards AFB and USACE Tulsa. We continue to receive task orders under some of these contracts because of the quality of MS2's work and reputation.

MS2 was able to win several contract vehicles called Indefinite Delivery/Indefinite Quantity (ID/IQ) contracts in which MS2 will receive task orders (projects). In the 2nd Quarter, MS2 received the following task orders:

- MS2-MEC JV – MS2 received two more task orders on the contract.
- ID/IQ NAVFAC SW Joint Operations Center (JOC) –MS2 received two more task orders on the contract.
- RAIES – MS2 is providing assistance to OTIE on five task orders on this project

In addition to ID/IQ contracts, MS2 has also been awarded stand alone, single project contracts from our government clients that we are currently executing.

- Army Contracting Command – Joint Munitions Command (JMC) Umbrella Contract which is a contract to support JMC Safety office at Rock Island Arsenal.
- NAVFAC Mid-Atlantic – Fort Snelling, MN – received a contract for security upgrades and fencing improvements. This utilized our Design-Build MACC contacts at Great Lakes Naval Station. This is a new client for MS2.
- Army Contracting Command, Joint Munitions Command – ARC Flash Project – contract to provide ARC Flash services at Pine Bluff Arsenal in Little Rock, AR and Bluegrass Army Depot in Lexington, KY. Work is nearing completion at Pine Bluff Arsenal, and the group is preparing to plan work for Bluegrass Arsenal in the coming quarter.
- Army Contracting Command, Joint Munitions Command – Safety Support – contract to provide 1 year of safety support at the JMC Safety office at Rock Island Arsenal.
- Pine Bluff Arsenal-High Speed Deluge System – Completed installation of deluge system modifications into an Ammo Production building at Pine Bluff Arsenal.

SRS has been awarded contracts by the following clients: US EPA, NAVFAC Mid-Atlantic (Great Lakes Naval Station), USACE Los Angeles District and US Fish & Wildlife Services. We continue to receive task orders under some of these contracts because of the quality of SRS's work and reputation.

SRS was able to win several contract vehicles called Indefinite Delivery/Indefinite Quantity (ID/IQ) contracts in which SRS will receive task orders (projects). In the 2nd Quarter, SRS received the following new task orders:

- US EPA START ID/IQ contract – issued three new task orders to include Terry Site removal, Dymet removal, and Zizzo Properties removal. Terry Site and Dymet are removal actions involving removal of drums and containers from an abandoned facility. Zizzo Properties a removal of soil and auto fluff contaminated with lead and PCBs.

In addition to ID/IQ contracts, SRS has also been awarded stand alone, single project contracts from our government clients that we are currently executing.

- NAVFAC Mid-Atlantic (Great Lakes Naval Station) – Phase II Navy Hazmat Refurbishment Project storage lockers will be transported to a facility in Oak Creek, WI to be cleaned, refurbished, repaired, painted and then reinstalled at their point of origin. Also includes installation of new storage lockers. The project was kicked off in the 1st Quarter and SRS plans were approved by the client.

- US Fish and Wildlife – Crab Orchard removal and abandonment of 150 monitoring wells was successfully completed during the 1st Quarter of 2017.
- Naval Base Great Lakes – SRS is assisting MS2-Belonger JV on the renovation of Building 3200.

g. Identification of key elements for success in strategies given, including risks, resources and relations available and needed in order to successfully fulfill outlined strategies

Key elements for success in the OESC model includes:

- Establishing and monitoring key performance indicators allow us to act early and manage the business going forward. Key performance indicators include safety, staff turnover, profitability, staff utilization, backlog and capacity.
- Adapting to a changing customer base, contract type, or key skill set. We recognize and reconfigure based on identified needs to delivery strategic growth.
- Identification of contract capacity and access is under regular review.
- Increasing our geographic footprint and capabilities

Risk in the marketplace

- We operate in highly competitive industries
- Contracting is often erratic and unpredictable; cancellations or delays in pending awards by government agencies could adversely affect us
- International operations carries additional risk
- Loss of key personnel
- The government may adopt new contract laws or regulations at any time.

h. Identification of medium (two to five year) and long (greater than five year) prospects and sustainability of the Corporation given the present status, strategies and risks

The medium and long range prospects for sustainability are balanced by business diversification and consistent project management delivery. The backlog of OESC's subsidiaries has grown and our utilization is high.

We have successfully groomed long-term business relationships with key US Agencies for services delivered around the world. Contracting with the US government remains a reliable strategy in terms of payment, stability, and growth opportunity. Our medium- and long-term prospects reinforce our projections for steady, sustained growth.

Medium-term prospects

The prospects of the OESC's subsidiaries in the two- to five-year term rely on the sturdy performance in engineering, science and construction to existing clients; adjacent clients/services and geographic areas; and new service offerings to new clients. The increased focus and investment in business development and talent acquisition has allowed us to significantly increase both new task orders and backlog going into FY17. We continue to strongly believe that OESC's capabilities and strengths align well with the future needs and demands of our clients.

Long-term prospects

OESC envisions steady growth with our key customers over the long term. Our subsidiaries are nimble and agile where they can focus on governments funding flows including where funds historically flow.

Continued reliance on low-price awards is a staple in our business model and we continue to adjust the pricing structure to ensure that we remain competitive across all business segments.

Similarly, we are concentrating our marketing efforts on maximizing our return on investment through expanding support for existing customers, developing tasks under existing contracts, and collaborating with firms that need either small business participation or our specialized expertise.

i. Explanation of market growth (if any) experienced by the Corporation, identifying sources of growth (i.e., organic growth through market share increase, volume of business increase, acquisition of competition or other assets, etc.)

As a top-tier contractor to the federal government, OESC subsidiaries have a large and diverse blend of federal, State, municipal, tribal and commercial business customers. Since inception of the subsidiaries, OESC’s growth has been all organic. Organic growth includes the hiring of key personnel with knowledge and contacts that offer OESC subsidiaries new and expanded opportunities.

j. Summary of the assets of the Corporation, including but not limited to its financial, physical, employee, customer, brand or intellectual property, and supply assets.

OESC ASSETS
<p><u>Financial (On Balance Sheet)</u> Cash –Checking Account Work In Process on Current Projects Fixed Assets such as Vehicles, Furniture and Fixtures, and Miscellaneous Equipment Other Assets such as Prepaid Expenses, Investment</p>
<p><u>Employees</u> OESC – 41 employees MS2 – 20 employees SRS – 14 employees</p>
<p><u>Customers</u> 95% of Revenue from Federal clients.</p>

k. Summary and status of any pending legal action to which the Corporation is a party and any relevant government regulation to which the Corporation may be subject.

No current pending legal action.

Oneida Business Committee Agenda Request

1. Meeting Date Requested: 4 / 27 / 17

2. General Information:

Session: Open Executive - See instructions for the applicable laws, then choose one:

Agenda Header:

Accept as Information only

Action - please describe:

Business Committee approval of report

3. Supporting Materials

Report Resolution Contract

Other:

1.

3.

2.

4.

Business Committee signature required

4. Budget Information

Budgeted - Tribal Contribution

Budgeted - Grant Funded

Unbudgeted

5. Submission

Authorized Sponsor / Liaison:

Primary Requestor:

Jeff House, OESC Managing Principal

Your Name, Title / Dept. or Tribal Member

Additional Requestor:

Name, Title / Dept.

Additional Requestor:

Name, Title / Dept.

Oneida Business Committee Agenda Request

6. Cover Memo:

Describe the purpose, background/history, and action requested:

Corporate reporting requirement - Business Committee approval of report

- 1) Save a copy of this form for your records.
- 2) Print this form as a *.pdf *OR* print and scan this form in as *.pdf.
- 3) E-mail this form and all supporting materials in a **SINGLE** *.pdf file to: BC_Agenda_Requests@oneidanation.org

Oneida Total Integrated Enterprises

2nd Quarter Report 2017 April 17, 2017

Prepared by:

Nick Ni, PE, President

OTIE Report 01-20170417



Narrative Report

a. Explanation of the core of the Corporation's business practices and market overview

Five core services contribute a majority of OTIE's backlog in response to federal and state project requirements, changing infrastructure demands, and the often accompanying regulatory challenges. OTIE provides:

- Environmental services
- Remediation
- Construction and demolition
- Engineering design and studies
- Munitions response services

We deliver these diversified services to government agencies, as well as commercial clients in the United States and across the world. OTIE has staff worldwide, continuing an upward trend of growth measured by staff count while some firms in our space have shrunk due to weaker financial performance.

Our business posture is configured to consistently provide solutions that offer our customers cost-effective mission support while adapting to evolving procurement strategies and budgetary pressures. Core service growth has established OTIE as vastly more diversified than ever before to win contracts that require multi-dimensional capabilities.

As a service-based company, OTIE revenue is primarily derived through the labor-based professional services, plus construction projects that can potentially return higher margins. On both pro-services and construction projects, we forego pursuit on opportunities with capital-intensive requirements and the accompanying buildup of depreciating assets. Instead, our growth is achieved by: retaining clients and attracting new ones; providing quality and responsive value-oriented project management at competitive rates; and retaining high-performing, dedicated employees.

Market overview

Markets continue to change and our business is evolving to address these changes. Environmental services and Munitions Response Services (MRS) continue to see declining potential due to market saturation and bundling of sites/service delivery requirements. OTIE succeeds by focusing our efforts on core and emerging sectors, well-funded service types, and reliance on partnerships to deliver high-dollar projects.

Regarding infrastructure engineering services, years of deferred maintenance by customers has created appreciable opportunity for OTIE serving federal agency customers, whose budgets have undergone belt-tightening and a corresponding requirement to "do more with less." Along with our competitors, OTIE strives to



capture the high labor projects that government spending on infrastructure improvements demands.

Broader economic recovery and industry confidence has created renewed investment through construction, and this creates value and opportunity in construction and demolition, driven by the energy/efficiency requirements and technology updating. While the adjectives “slow and steady” remain prominent, headwinds are dropping to help stimulate recovery. Construction and construction management (including Title II) services represent a significant portion of OTIE’s revenue potential over the next five years.

As reported in prior Annual Reports, the market for our services remains highly competitive. An abundance of Architecture / Engineering / Construction (AEC) firms provide similar services offered by OTIE. Competitive factors for our success include performance reputation, price, geographic location and availability of technically skilled personnel. We are pleased with our accomplishments which reinforce our market leadership as a small business competitor.

Operational tactics in the marketplace

OTIE directs our primary business pursuits from a stable customer base concentrated in federal, State and municipal government entities. We progressively develop and position for federal opportunities and target large program offerings at state, municipal and tribal levels.

As a technical consultancy, we provide studies, design and engineering together with project management skills for a growing roster of clients. Added resilience occurs through prospecting for projects in other regions/with other tribes, and in adjacent technical services. Our tribal business, aerospace industry (commercial), and electric utility company contracts are exceptions to OTIE’s heavy reliance on government contracts, and in all cases our customer base offers outstanding opportunity for securing projects and targeting:

- long-term, high-dollar contracts to offer steady and profitable backlog
- low risk contracts to stabilize the Company’s business base
- capturing market share in emerging or expanding growth markets

Our strategy focuses on maintaining our top-tier position with select federal agency customers; realizing the opportunities arising from infrastructure investment; and from the budgetary spend in environmental programs. OTIE’s transportation, tribal and munitions response capabilities provide added diversity within our core services.

Success implementing OTIE’s preference for long-term contracts is demonstrated in our win at Thornberry Golf Course, where we enjoy residual opportunity over and above the initial project that was awarded. Similarly our operational tactics with our WisDOT customer produced a win for IH-39 Rock River Bridges and STH 59 Interchange Reconstruction, providing lasting value on a high-visibility project.



Our operational excellence continues to improve the underlying processes of the business, ensuring increased time to focus on our clients' needs and project delivery.

b. Explanation of the Corporation's current place within the market

OTIE is a Native American, tribally-owned, SBA-certified 8(a) small disadvantaged business (SDB). Other small business categories in the marketplace include: HUB-Zone; Woman-owned; Veteran-owned; Service Disabled Veteran-owned; Alaskan Native Corporation; Native Hawaiian Owned; and Native American-owned.

OTIE operates in a fiercely competitive, expanding market that seeks diversity and economic vitality through government contracting. Our advantage over emerging small business competitors is maintained through steadfast conformance with quality, safety and contracting/acquisition requirements and regulations imposed by the federal government. We pride ourselves in offering "no drama" project performance, and continued requests for OTIE project leadership occurs.

Looking at the 8(a) market, OTIE is clearly distinguished from others by our size and longevity as a company. Now in our third decade of business operations, we are a mature, tested and proven small business with infrastructure that rivals many large businesses. We believe that our present size and diversified service offerings - relative to the smaller, niche companies - are advantageous to OTIE.

The company's position in the marketplace remains healthful and configured for future success. To sustain and expand our place within the market, OTIE budgets and expends significant funds in Bid & Proposal (B&P), marketing, advertising and conference participation. We limit expenditures on trade shows and conferences to events wherein OTIE holds a present market position and potentials growth can be directly tied to attendance.

Our financial and project performance are coequal metrics that are tracking along gradual improvement vectors, and are indicative of steady growth instead of punctuated spikes that are harder to sustain. With the hard work and support of a diverse and talented workforce around the world, we have confidence in our strong position within the marketplace, and that we can make a difference to the world we live in. OTIE remains appropriately configured for the year ahead despite continued uncertainties in some of our markets.

c. Explanation of the outlines of strategies by the Corporation for improved value in the market

Improving our value and position in the marketplace directly corresponds to delivering profitable growth for the Oneida Nation. OTIE strategically identifies opportunities with government and other customers where funding is reliable and alignment with our core competencies is commensal. Examples include engineering services, Munitions Response Services (MRS), and design/construction contract management.



We also target areas that we believe are attractive for building professional development for our staff. For instance, our Atlanta office has focused heretofore on EPA START program support, but recently crafted a winning strategy for a groundwater monitoring and optimization project at Air Force Plant 6 in Georgia. OTIE's EPA-experienced staff have diversified their customer base and built new credentials for future similar pursuits.

More specifically, the following elements drive our strategy going forward:

1) Pursuing larger contract opportunities. With continued development of a strong infrastructure and expanded engineering capabilities, we focus on pursuing larger prime contracts and expanding our pool of opportunities. We continue to strengthen our relationships with other firms to create teaming arrangements that better serve our clients, but our goal remains prime contracts instead of team-sub positions.

2) Leveraging of our services. OTIE has diverse services to offer to a growing customer base. As OESC integrates, we remain vigilant for 8(a) set-asides for OTIE, MS2, and SRS. The combination of our multiple skill sets and broad service offerings allows us to work efficiently in a crowded market, whether selling services, or via effective use of our design and construction management skills supporting DoD and bridging such skills to other customers such as the Oneida Nation. Our strategy for leveraging all three companies is intentional and focused; the methodical integration of OESC companies will generate opportunity and sustained value.

3) Expanding our international footprint. OTIE is one of AFCEC's select, "go-to" AE firms for Title I and Title II services. Our forward operating presence in Guam has strengthened OTIE's position in Asia/Pacific. Based on superior OCONUS performance the AFCEC awarded the OTIE-RS&H JV a Task Order in Qatar for AE Services at Al Udeid Air Base.

4) Investing in our people. We are committed to building on our employee's accomplishments while expanding our reach through new hires. Continued profitable growth is projected to occur through our carefully executed hiring strategies. OTIE attracts and hires staff who improves our resource depth and competitive position in the marketplace.

5) Geographic and client expansion through acquisition. We will direct an active acquisition strategy focused on expanding our ability to offer our technical services in new geographic areas and with new clients through the acquisition of complementary businesses. While we continue to invest in our people, we must continue to methodically pursue potential acquisitions. Being disciplined in valuing and structuring the transactions, OTIE avoids acquisitions merely for the sake of revenue.

Overall, OTIE's strength in the market is built on relationships with key customers, and our ability to discover new opportunities early in the acquisition cycle and respond with discipline and direction. OTIE's strategy is to:

- Get in front of the right people



- Present compelling information and arm the company with winning tactics
- Partner with proven industry leaders preferred by the customer
- Reinforce our sales tactics with proven past performance.

By marketing to the right decision-makers, and conducting objective determinations on potential for success, OTIE fiercely competes when probability for success is high, and we forego opportunities where we see minimal chance of success. Using this focused approach reduces costs and improves our win percentage, both of which are key components of building value in the marketplace.

OTIE is optimistic that federal funding will remain durable. Our long term ID/IQ contracts should provide outstanding pipeline and backlog generation. Our simplified organizational structure will deliver improved efficiency and, coupled with volume growth, will support margin improvement.

d. Explanation of the Corporation's relative performance vs. competitors and identification of key competitors within the market

As presently classified, OTIE is an SBA-approved 8(a) SDB and our competitors include: Alaskan Native Corporations (ANCs); Native American, tribally-owned small businesses; and Native Hawaiian Organizations (NHOs). Each of these business concerns is treated in a category of small businesses that may be awarded prime contracts without competition. OTIE also competes against other 8(a) firms for set-aside acquisitions, including small businesses that are categorized as Woman-Owned, HUBZone, Service Disabled Veteran Owned small business, and others.

Typical competitors for OTIE include:

- Small Business firms with fewer than 750 employees in NAICS 562910 (e.g. Baywest, EA, Conti, Versar, Severson and others) plus regional transportation engineering firms in Wisconsin.
- Current 8(a) small businesses (Ahtna, Bristol, Prudent Technologies, CIRI, companies like Northwind, and others).
- 8(a) "graduates" (e.g., Bhate, CAPE, ERRG, HGL, Nobis, Tidewater, and others). These small businesses are now mature businesses developing past performance and earning customers that keep them "entrenched" in specific situations.

In April 2017 OTIE will be an 8(a) graduate and Small Business under the size standards for NAICS 562910. We will no longer receive 8(a) direct award contracts, which has been a mainstay for our business growth and diversification. However, OTIE is already viewed by other small businesses as extremely competitive on major ID/IQ prime acquisitions. Our federal agency customers have commended OTIE on the high quality of our ID/IQ contract proposals, as well as the ease of negotiations and businesslike interactions. This reputation and competitive edge provides substantial confidence for OTIE's long-term success as an 8(a) graduate.



In the Eastern region on task order proposals, OTIE has struggled against other Small Business competitors to win work under Multiple Award Task Order Contracts (MATOC). On balance we fair better under Best Value procurements and tend to lose out on opportunities awarded based on Low-Price, Technically Acceptable evaluations. We will continue to focus on improved processes to win competitive task orders on all of OTIE's MATOC tools.

One of our best prospects for market expansion remains in the PFCs arena, where OTIE has a significant advantage having entered early in this emerging and high-profile business area. Several DoD agencies such as NASA and NAVFAC are targets for customer diversification in PFC site investigation.

OTIE remains well positioned for continued DoD work overseas, especially in Asia/Pacific. The Defense Department's force posture in Asia aligns with OTIE's planned growth: We are pre-positioned for profitable contract performance in Japan, Guam and potentially Australia, where the DoD focus has pivoted, and we are reaping the rewards of the long-term vision and investments already made.

OTIE has garnered nationwide (and international) attention as a vigorous competitor. We have fended off competitors for AE Services in the Pacific like Jacobs and CH2M. We hold a wide variety of diverse federal contracts, and our superior performance on these contracts makes OTIE very hard to out-compete.

e. **Explanation of any material changes or developments in the market or nature of business the Corporation is primarily engaged in since the last reporting period**

A regulatory change by SBA in 2016 increased the small business size standard in our primary NAICS code (562910) from 500 employees to 750 employees, a 50% increase. Within small business circles, OTIE remains a sturdy, medium-sized competitor, but this regulatory change welcomed in a few larger, robust competitors like Conti, Versar and Parametrix. Some competitors are large firms with vast financial resources, requiring OTIE to be selective in our marketing and sales efforts and more adept in developing strategic partnerships to enhance our competitive advantage.

Additionally, SBA adjusted the long-standing Mentor-Protégé Program (MPP) regulations to permit a small business of any category (Woman Owned small business, Veteran Owned small business, HUB Zone, etc.) to establish an MPP with a large business. The impact of this change is that the approved MPP firms may submit a Joint Venture bid on a federal acquisition and compete against other joint or individual small businesses. Also, the agency has accelerated the review/approval process for MPP application, which is a change from the ordinarily long waiting period for small business and large business partners' applications like OTIE faced with our partner CH2M.

To counteract the increased competitive landscape, further fortification of the Oneida Nation's invested capital can help our "sister" companies become stronger, and better



positioned to build a performance history to compete for more 8(a) direct awards. OTIE's strength has assisted Sustainment Restoration Services (SRS) to win an 8(a) direct award from the US Navy. With strengthened financials and a growing past performance history, each of the Oneida Nation's companies becomes more competitive and offers the ease of contracting options that our federal customers desperately need.

In spite of changes in our industry, our ability to adapt to the evolving needs of the marketplace has enabled us to build a resilient business that is closely aligned to the spending priorities of our federal clients. Our diversified portfolio steadies OTIE against market fluctuations and regulatory changes, as does the fact that a number of our most important markets remain well funded.

Because we are accustomed to competing against formidable small and large businesses, OTIE is configured to succeed in an atmosphere of increased competition and reduced budgets. Our business development strategies aim to collect early information on upcoming procurements, affording us time to develop winning strategies and allowing us to sharpen our pricing. Coupled with time-tested partnerships in industry, we form teams that are among the most formidable, value-adding propositions available to our customers.

- f. Identification of the primary goals and targets of the Corporation and progress made towards accomplishment of the same

Goals for OTIE

Growth is the primary business goal for OTIE. Success for OTIE comes when we align and invest along growth profiles and manage/measure accordingly to make sure that our clients prosper.

OTIE became an Oneida ESC Group subsidiary firm, joining SRS and MS2. This required swift adaptation and adjustment – a process that continued through much of 2QFY17 as financial, HR and BD groups became consolidated under the common management structure and protocol.

During this reporting period OTIE is pleased to have secured new contracts with our USACE customer for environmental services in geographic areas that provide growth potential. The Corps Omaha District and the Tulsa District each awarded an ID/IQ single-award contract to OTIE. These two agencies favor SATOC contracts for project execution; effort to award task orders is streamlined and immune from bid protests. The task order awards on SATOCs are not open for bidding among multiple contract holders. Accordingly, we anticipate brisk and plentiful depletion of the combined contract capacities, providing substantial opportunity for business growth and development.

Our NAVFAC Southeast contract was unused by the agency for almost five years, but in the current reporting period OTIE and our EMAC competitors received a spate of



RFPs. We proposed on seven and won two task orders for environmental services in Florida. The flurry of activity provides opportunity to build past performance for future contract proposals.

These contract awards were augmented by other new starts with the Oneida Tribe plus healthy growth under existing AE Services contracts with the USAF, and with our single largest customer, the US Army Corps of Engineers. Steady performance for our WisDOT and EPA customers provided healthy and consistent returns as well.

Expansion of technical resource depth

Our design and engineering business has performed well during the year with strong volumes and high productivity, with new licensed professionals hired in disciplines such as mechanical, electrical and structural engineering. Under OTIE's USAF contracts we are now performing engineering studies, evaluations and reports with engineering recommendations on water, wastewater and asset management services.

Winning the AFCEC AE13DCS contract was a crucial first-step to retaining our position and relationship with our Air Force customers; we are expanding our resource depth and maximizing opportunity for growth and development under this contract. A healthy pipeline of AE services work remains throughout the 4-year ordering period and 7-year performance period together with our JV partner and supporting our US Air Force customer.

Geographic expansion

OTIE has embraced the challenges of expanding into new geographies by winning work in two remote/austere locations as follows:

- Under our Range AE Inspection Services (RAIES) contract with the US Air Force's 45th Space Wing, OTIE won a design for runway improvements on Ascension Island. The runway is located in very remote equatorial waters of the South Atlantic Ocean, around 1,000 miles from the coast of Africa 1,400 miles from the coast of Brazil, which is roughly midway between the horn of South America and Africa. The long term benefit of OTIE's work is direct, prime contractor experience on DoD runway and airfield design and improvement services, and in a very remote region.

Under the US Air Force's Design and Construction Services (DCS) contract with JV partner RS&H, OTIE will deliver Title I Design and Title II Construction Management services for twelve discrete projects at Al Udeid Air Base in Qatar. Al Udeid AB houses foreign coalition personnel and assets and is headquarters of United States Central Command in the Middle East. OTIE will feature this work experience to broaden our roster of DoD customers and experience working in hostile locations.

Targets for OTIE

OTIE targets growth in government contracting where our skills and experience align with our customers' mission priorities. In the aggressive market of federal agency



contracting - especially in times of budgetary uncertainty - every advantage is crucial to maintain OTIE's position in the elite levels of small business contracting. Gaining a competitive advantage takes strategic planning and research to focus on opportunities that are robust (high confidence customer spend) and enduring (affording long-term growth opportunity). We pursue emerging or growing markets and seek entry and profit in these areas, while closely monitoring risks and barriers. Identified market segments or locations for expansion by OTIE include:

- Facility/infrastructure engineering and asset management
- Diversified environmental services
- Munitions Response Services (MRS)
- Expansion of USEPA services, contracts and Regions
- Growth in the Asia/Pacific region, plus the Southeast US

Described below are the accomplishments for OTIE's targets.

Facility/infrastructure engineering and asset management – aging DoD real property/infrastructure is a target with legitimate potential for sustained growth. Over the last five years OTIE has expanded the engineering services we provide to our customers. We are delivering engineering projects across the mainland US plus Hawaii and Alaska and at DoD installations in Qatar, Japan and Korea. We are winning engineering projects for facility/infrastructure design improvements that have typically been awarded to competing engineering giants like Jacobs Engineering, AECOM, and CH2M.

Diversified environmental services – Under two prime contracts, OTIE is serving the US Air Force's needs for site investigation of the emerging contaminant, PFCs. We anticipate additional opportunities with USACE Districts, potentially including an 8(a) direct award in FY17.

Munitions Response Services (MRS) – OTIE is one of the only 8(a) firms with broad capability and past performance in MRS, affording significant competitive advantage to OTIE. But contract spending by DoD has been slow, and select opportunities have been bundled as consolidated contracts. This affects new opportunities for ID/IQ contracts in FY17 and beyond. Slowly building past performance, OTIE remains committed to delivering MRS services, and potentially combining MRS with our other traditional engineering skill sets.

Expansion of services/contracts with USEPA – OTIE was awarded a significant work assignment at the AMCO site in Northern California under the USEPA Region 9 8(a) site-specific RAC. In addition to the work we provide under the prime START in EPA Region 4, and we have submitted on three new EPA contracts that will be awarded in late 2017 under the EPA's revised Remedial Action Framework.

Growth in the Asia/Pacific region – Projects performed by OTIE in Asia include Air Force and USACE contracts. Over the last ten years we have systematically expanded



the service offerings and the level of self-performance by OTIE instead of team subs. With offices in Hawaii and Guam, OTIE is pre-positioned to win projects to support the DoD’s rebalancing and force posture within the Pacific.

Growth in the Southeast US – OTIE has a long-standing business operations in Atlanta, GA, and Oak Ridge, TN. Boosting this sustained presence is our more recent success in the Space Coast region of Florida. We have secured 8(a) contracts with USACE Savannah District, and we have two additional competitive proposals submitted to the Savannah District. Significant opportunity exists for further growth and diversification in this region.

g. Identification of key elements for success in strategies given, including risks, resources and relations available and needed in order to successfully fulfill outlined strategies

Markets have changed and our business continues to evolve in to order uphold our value and competitive position. With 8(a) graduation approaching, three primary categories or “pillars” capture OTIE’s strategic focus over the next five years. All of the objectives and goals – *internal and external* – that we identify flow up to support one (or more) of the following three overarching pillars of our strategy:

Pillar	Description
Operational excellence	Objectives emphasize optimizing financial delivery on all our projects. Strategies and tactics to improve: corporate infrastructure critical to supporting operations; business development; quality and safety integration; and HR services improvements.
Portfolio optimization	To ensure configuration for future success, we create plans for each business in our portfolio, continuing to focus on smarter growth and higher margin activities. We establish areas of particular focus for investment, and monitor, measure and adapt over time.
Subsidiary and regional improvement	Our regions, Business Units and subsidiary companies have attractive growth prospects. Business maturation is a gradual, stepwise process that requires proactive strategies to becoming fully-fledged.

Key elements for success include:

Establishing and monitoring Key Performance Indicators (KPI) – Our KPIs measure past performance and also provide information and context to anticipate future events and, in conjunction with our detailed knowledge and experience in the markets in which we operate, allow us to act early and manage the business going forward. We track safety, staff turnover, profitability, efficiency, backlog and resource capacity.

Plotting and following strategies for service diversification – Within our project and program management functions, we identify actual or potential performance gaps, and we use these data to inform and advise how to re-shape the business, adapting to a changing customer base, contract type, or key skill set. We recognize and re-configure based on identified needs to delivery strategic growth.



Cross-selling OTIE services – Between OTIE regions, great diversity of project capabilities exists. Our challenge is to leverage the diversity that we enjoy and cross sell our services in other geographic areas.

Opportunity identification for subsidiary exploitation – If contract access is a concern for any customer, OTIE identifies and promotes our subsidiary company capabilities, either for self-performance or in partnership with another firm(s). We treat this as a key enterprise-wide goal for transferring 8(a) direct award opportunities to subsidiaries as a growth model.

Understanding and balancing risks between organic expansion and acquisition – As we seek further growth, we examine tactics to harness our speed to market. While organic growth may be safer (low risk) the drawbacks could come from lost opportunity. High risk acquisitions can more quickly configure us for service diversification and penetration into market, but integration and other explicit and embedded risks are examined and determined. Key to our success will be orderly and methodical procedures for exploring and proffering arrangements for acquisitions.

Increasing our geographic footprint and capabilities – In an expanding global marketplace, OTIE evaluates our strategies for expansion. For example, we are pre-positioned in Asia/Pacific with offices and past performance that eases the justification and approval process for source selection on several OTIE contracts.

Recalibrating corporate infrastructure to optimize operational efficiencies

Understanding that BD feeds Operations, and our Contracts, Finance & Accounting are in a support posture to the operations group, OTIE understands and adapts our organizational structure for natural market-driven developments that trigger internal change. We understand these relationships, and we reorganize when necessary, and based on new hires, new technologies and raw growth of the enterprise.

To uphold and fulfill OTIE's value and position in the marketplace we focus on those opportunities where the federal government continues funding and that clearly align with OTIE's customers, such as engineering services, Munitions Response Services, and design/construction contract management. We also continue to focus on areas that we believe offer attractive enough returns to our clients that they will continue to fund efforts, such as Military Family Housing design (Title I) and construction type services (Title II) including infrastructure improvements internationally, and studies and assessments for emerging contaminants like PFCs.

We have grown OTIE into an elite, highly capable small business, and we have out-competed small and large businesses for some of our industry's most prized contracts. As a very credible competitor, our staff growth and geographic distribution enhances our win potential and our resources to sustain and support our customers' mission. Going forward a challenge for our Regional Managers and Business Unit Managers is to identify and equip project-level staff to continue to grow the business. We are committed to sustaining internal efforts, such as investment in our people, such that "seller-doers" have the necessary training and tools to identify and win new work.



Risk in the marketplace

Our service lanes are sturdy, lucrative and rich in potential, and we anticipate much prosperity in the years to come. However, risks in business are a constant, and lasting companies endure risks with careful plotting for avoidance, and calculated mitigation once the risks are encountered. Acknowledged risks for OTIE include:

- We operate in highly competitive industries and contracting is often erratic and unpredictable; cancellations or delays in pending awards by government agencies could adversely affect us
- Our inability to win or renew government contracts could adversely affect us
- We expose the company to risks associated with operating internationally
- Our failure to properly manage projects may result in additional costs or claims
- An economic downturn may adversely affect our business
- In order to succeed we need to keep up with a variety of rapidly changing technologies
- We are highly dependent on key personnel
- Acquisitions may not go as expected and may have unexpected costs and consequences
- The government may adopt new contract laws or regulations at any time.

Fundamental keys to success are our personnel, infrastructure, financial strength, and cost-consciousness. If any one of these requirements is neglected, OTIE will miss our goals and targets, and competitors may capitalize on weaknesses and gain market advantage. These key OTIE features mold our strategies and processes for identifying growth opportunities that align our business – services, customers, channels and geographic areas – and augment the largest proportion of revenue and profits.

Business relations in the marketplace

OTIE's organizational structure aligns with client expectations and industry standards. Being customer focused, we grow the business by implementing principles and strategies to:

- Organize work around results that customers consider valuable;
- encourage operational accountability and concentration on high-quality achievements;
- create streamlined and flexible relationships in response to customers' evolving needs; and
- provide employees with corporate support required to create opportunities and grow our company.



As an expanding small business enterprise, OTIE successfully strengthens our market position based on our systematic business development processes and our responsive value-added proposals. We generate revenue and profit after successfully winning work under our hard-fought proposals. And we provide an outstanding level of service delivery, which ultimately determines our customers' propensity and desire to continue a business relationship with OTIE.

OTIE Educational and Other Outreach Programs

OTIE continues to implement its outreach programs with the Oneida community and membership that focuses on the Oneida youth education, elders and veterans. Our support in educational activities and opportunities for Oneida youth to encourage their consideration of careers in engineering and science will include: 1) sponsorship of up to two Oneida high school students to attend a Milwaukee School of Engineering summer camp session to learn more about engineering and a potential career in the engineering field; 2) award up to two \$5000 merit scholarships to an Oneida-member high school senior and/or a college-level senior for excellent academic performance and the desire to study the sciences for a potential career in engineering or environmental sciences; 3) sponsorship of math and technology activities for Oneida middle school students; 4) OTIE is exploring the opportunity to provide internship(s) for Oneida students.

OTIE will also continue to sponsor ongoing tai chi and chair yoga exercise classes for the Oneida elders to support the health and well-being of the elders. This sponsorship is accomplished with the assistance of Oneida Elder Services and the Oneida Fitness Center. OTIE has explored and identified available sponsorship options with Oneida Veterans groups.

h. Identification of medium (two to five year) and long (greater than five year) prospects and sustainability of the Corporation given the present status, strategies and risks

While a return to more tepid economic growth fills OTIE's sail, the uncertain status of the hotly-debated National Defense Authorization Act (NDAA) presents some navigational challenges. Still, we are buoyed by our balanced and diversified business, plus our consistent delivery on revenue and profit to the Oneida Nation. In OTIE's backlog has grown and our utilization is very high — all indicators that being diversified safeguards the Tribe's investment.

We have successfully groomed long-term business relationships with key DoD agencies for services delivered in the Continental US and around the world. With a solidified agreement by the US Congress on federal budget initiatives, government contracting remains an exceptionally reliable market in terms of payment, stability, and growth opportunity. Our medium- and long-term prospects reinforce our projections for steady, sustained growth.



Medium-term prospects

OTIE's prospects in the two- to five-year term rely on our sturdy performance in engineering, science and construction to existing clients; adjacent clients/services and geographic areas; and new service offerings to new clients. OTIE's increased focus and investment in business development and talent acquisition has allowed us to significantly increase both new task orders and backlog going into FY17. We continue to strongly believe that OTIE's capabilities and strengths align well with the future needs and demands of our clients.

Existing Services/Existing Clients

Maintaining quality service to existing clients is a top priority for OTIE. Our best business development comes through the customers we already serve, and this fundamental tenet of business operations will become gospel in all OESC companies. Outstanding performance allows our good reputation to flourish and paves the way for follow-on contracts, task orders and "cross-selling" potential.

OTIE will continue providing services to our existing customers, aiming to exceed expectations and become the preferred provider. Internationally and locally we see very strong alignment between our capabilities and the services our customers require, including WisDOT, Oneida Nation, DoD and EPA.

In FY16 we continued to reinforce key growth areas for DoD customers. Examples include: Munitions Response Services and environmental services; and strategic actions by the company that provide legitimate growth and align with our customers' spending trajectory.

- **Munitions Response Services (MRS)** – Our acquisition of OER equipped OTIE with broader capabilities in the MRS market, and with support from specialty providers, such as geophysics we are making steady progress growing our presence in this market. We will actively pursue customers that seek combined services as we leverage our capabilities into the changing MMRP environment.
- **Environmental Services** – Over the years, OTIE has managed more than 40 environmental ID/IQ contracts, ranging in value, each with as many as 30 or more concurrent TOs. For example, on our AFCEC 4PAE08 contract for the USAF, we managed 29 projects, including 10 concurrent, across four CONUS time zones and OCONUS. We have performed over 400 TOs for the USAF. OTIE's performance history with the USAF, coupled with our technical experience and capabilities with groundwater monitoring, created the opportunity that led to a direct award for site investigations at USAF installations to characterize that nature and extent of PFCs in groundwater. Looking forward, this direct experience has OTIE uniquely positioned as a small business competitor in a growing field.



Customers will continue to rely on OTIE as integral to their success. We deliver their most valuable projects safely, on time, within budget, and to their quality requirements. In the two- to five-year term we will work closely with them to find practical and innovative solutions, adding tactical value.

“Adjacent” Clients, Services and Geographic Locations

Bridging out to new clients or offering new services to existing clients is an important component of our vision for growth. In FY16 we merged the skills we offer into new client groups and geographic areas. One such example is the 8(a) direct award that OTIE received from the US Navy’s Expeditionary Warfare Center (EXWC), with justification and approval relying on our exemplary performance with EXWC’s “parent” division, NAVFAC Southwest. In the two- to five-year term we will follow and build upon this success, competing for multi-year Navy contracts nationwide.

OTIE’s two- to five-year strategy originates from our focus on current customers whom have strong strategic links to the core of our business. Meetings with the most creative/innovative customers can be a valuable source of potential opportunity for OTIE. For example, we met with leadership at Al Udeid AB in Qatar to replicate OTIE’s success in PACAF for similar AE service offerings in the USAF Central Command. Exceptional opportunity exists to follow this model at other locations

New/Strategic Services, Clients and Geographic Locations

OTIE expanded to meet customer requirements by adding engineering disciplines in FY16 including electrical and mechanical engineering. We see these key areas as having growth potential in the near future with current and future clients.

An exciting growth opportunity has come about in Cocoa Beach, FL. OTIE will lead a design-build runway improvement in the remote Ascension Island. We are optimistic about building upon this experience to capture other AE services addressing airfields/runways.

In geographic regions like the US Southeast, OTIE is better positioned to find business growth in Atlanta by winning the Air Force Plant 6 groundwater monitoring and operations contract. In addition, we are teamed with some top-tier partners in this key geographic area for OTIE’s growth.

These and other new customers and locations present outstanding opportunities for service growth and diversification. In FY17 OTIE will continue the drive to target customers and new markets for additional projects.

Long-term prospects

OTIE envisions steady growth with our DoD and USEPA customers over the long term. Considering that over one-third of the federal budget is devoted to defense spending, OTIE delivers projects where funds historically flow and our competitive posture has continued to improve in the last decade. On one of our best contracts, the



US Air Force's AE13DCS contract, our Joint Venture is currently ranked third by dollar volume of awarded task orders. This puts our performance ahead of some large engineering stalwarts, and this ranking could continue over the life of the contract.

Continued reliance on low-price awards is a known risk, and we continue to adjust OTIE's pricing structure to ensure that we remain competitive across all business segments, while remaining conscious of the need to deliver profitable performance. Similarly, we are concentrating our marketing efforts on maximizing our return on investment through expanding support for existing customers, developing tasks under existing contracts, and collaborating with firms that need either small business participation or our specialized expertise.

We believe that the five year period up to 2021 will be stable years for OTIE. Being well positioned in key markets and critical geographic locations, we are confident that the long-term strategy of diversifying our offerings, maintaining geographic reach, and focusing on our customers' business objectives will continue to serve us well. The prospects look particularly optimistic in the Asia/Pacific region, where OTIE has methodically expanded our presence and our service offerings. In addition, our early and effective penetration into the PFCs contamination market will allow OTIE to hold its position, capture more work, and expand our resource depth.

Graduation from 8(a) status presents potential risk for OTIE. We mitigate the graduation risk by virtue of having previously (and successfully) graduated the program when doing business as T N & Associates, Inc. We know from experience not to expect "graduation gifts" and that the best success strategy is to be prepared and to be experienced competing for work.

- i. Explanation of market growth (if any) experienced by the Corporation, identifying sources of growth (i.e., organic growth through market share increase, volume of business increase, acquisition of competition or other assets, etc.)

As a top-tier contractor to the federal government, OTIE has a large and diverse blend of federal, State, municipal, tribal and commercial business customers. We provide science, engineering, construction, and specialized technical services to DoD, USEPA, WisDOT and other customer groups in support of a wide range of mission-critical programs.

Since inception of the company, OTIE's growth has been primarily organic or internally driven. Organic growth presents sales and BD potential only if we hire top-caliber employees with connections, knowledge and experience in the market.

In addition to internal or organic growth, our current strategy involves growth through additional acquisitions of complementary businesses, as well as growth from acquisitions that would diversify our current service offerings. We frequently engage in ad hoc evaluations of potential acquisitions which, if warranted are further explored. If consummated, new acquisitions could be significant to OTIE's growth.



Having expanded the volume of work performed for DoD customers outside the continental US, we see outstanding potential for market growth internationally and in the Continental US. We have established a solid presence in Asia/Pacific with offices in Hawaii and Guam, plus project offices in Japan. In the CONUS we are beginning to capture work with the Illinois Department of Transportation, and we view this neighboring state as ideal for prospecting based on our WisDOT history and performance. Lastly, our prospects for further growth in the Southeast US are attractive and promising for OTIE.

- j. Summary of the assets of the Corporation, including but not limited to its financial, physical, employee, customer, brand or intellectual property, and supply assets.

OTIE ASSETS

Financial (On Balance Sheet)

Cash – Checking Accounts
 Accounts Receivable from Customers
 Work In Process on Current Projects
 Fixed Assets such as Vehicles, Furniture and Fixtures, Survey Equipment, Monitoring Equipment
 Goodwill from the purchase of T N & Associates
 Other Assets such as Prepaid Expenses, Investment in Joint Ventures

Employees

Total of 292 Employees
 91 Engineers
 82 Scientists
 18 Construction Professionals
 26 Technicians
 6 Skilled Trades
 21 Administrative
 4 Land Surveyors
 36 MMRP/UXO Specialists
 8 Military Base Security Specialists

Customers

77% of Revenue from our Federal clients, such as the Department of Defense, which includes the Air Force, Navy, and Corps of Engineers. Other Federal clients include the Environmental Protection Agency
 6% Commercial – WE Energies, Raytheon
 8% State and Municipal – WI Department of Transportation, California National Guard, Ventura County, City of San Marcos, Division of State Facilities
 9% from Oneida Nation



- k. Summary and status of any pending legal action to which the Corporation is a party and any relevant government regulation to which the Corporation may be subject.

OTIE is named as a defendant in a lawsuit filed by the artist of a mural. The case is Kammeyer v. USACE.

In 1976, Kammeyer painted a mural on a dam in California after winning a contest. The mural was painted as part of the bicentennial celebration. Over time, the paint began to flake off, thereby contaminating the environment around the dam. The USACE Los Angeles District recently determined that the paint used to create the mural was lead-based. OTIE was hired by USACE to remove a mural to stop the lead-based paint contamination. Several months after the contract was awarded, Kammeyer filed a lawsuit against USACE and OTIE to prevent the destruction of the mural. Shortly after filing the lawsuit, Kammeyer filed a temporary restraining order against USACE and OTIE in June 2015, which was granted by a judge one day before OTIE was to begin removing the mural. OTIE demobilized from the site at USACE's direction.

OTIE has hired local counsel to represent OTIE's interests in the lawsuit. OTIE requested plaintiff's counsel to remove OTIE from the lawsuit by not including OTIE as a defendant in plaintiff's second amended complaint. Plaintiff's counsel refused. On August 24, 2015 the court granted the plaintiff's motion for a preliminary injunction. The court found in favor of the plaintiff on nearly every issue, but did not address any of the claims against OTIE. OTIE's next step is to decide whether to file a motion to dismiss. USACE has issued a notification of termination for convenience of the contract.

Oneida Business Committee Agenda Request

1. Meeting Date Requested: 4 / 27 / 17

2. General Information:

Session: Open Executive - See instructions for the applicable laws, then choose one:

Agenda Header:

Accept as Information only

Action - please describe:

3. Supporting Materials

Report Resolution Contract

Other:

1.

3.

2.

4.

Business Committee signature required

4. Budget Information

Budgeted - Tribal Contribution Budgeted - Grant Funded Unbudgeted

5. Submission

Authorized Sponsor / Liaison:

Primary Requestor/Submitter: Pete King, III; Managing Agent
Your Name, Title / Dept. or Tribal Member

Additional Requestor: _____
Name, Title / Dept.

Additional Requestor: _____
Name, Title / Dept.

Oneida Business Committee Agenda Request

6. Cover Memo:

Describe the purpose, background/history, and action requested:

Quarterly Report

1) Save a copy of this form for your records.

2) Print this form as a *.pdf *OR* print and scan this form in as *.pdf.

3) E-mail this form and all supporting materials in a **SINGLE** *.pdf file to: BC_Agenda_Requests@oneidanation.org



Oneida Seven Generations Corporation

Narrative Report:

Explanation of the core of the Corporation's business practices:

The purpose of Oneida Seven Generations Corporation (OSGC) is to promote and enhance economic diversification on behalf of the Oneida Tribe of Indians of Wisconsin. OSGC manages commercial developments such as the Bellin facility on Commanche Avenue, the Schneider facility on Glory Road, the Badger Sheet Metal Works facility on Partnership Drive, and the West Mason and Packerland malls. As of March 2017, we have two properties with lease space available; they are the restaurant space at the Travel Center, and an office / retail suite on Packerland Drive. We have talked with potential tenants on the available spaces. There are fifteen properties under OSGC's management; with over thirty leasable areas.

Explanation of the Corporation's market information:

Property Management: OSGC employs one part-time tribal elderly member who assists in managing approximately 30 tenant leases. In addition to monitoring the leases, the leasing person assists in making sure the corporation buildings are insured and that tenants insure their occupancy, implementing property management procedures, and compiling data information.

Identification of the primary goals and targets of the Corporation and progress made towards accomplishment of the same:

The vision for OSGC is to increase the profitability of the company's income real estate base by searching for development opportunities. The primary goal is to promote the benefits of the Free Trade Zone and the HUB Zone properties that are available through OSGC.

The progress we have made towards this goal: working with local Chambers of Commerce to pursue potential tenants.

We are also marketing our properties through Facebook and other social media outlets. We have seen an increase in properties being marketed through the internet which is less costly and has the ability to reach more businesses looking for space. In order to remain competitive we are moving into this market area.



Oneida Seven Generations Corporation

Identification of medium (two to five year) and long (greater than five year) prospects and sustainability of the Corporation given present status, strategies and risks:

Our medium to long range goals includes the following:

- To dissolve OSGC, per the GTC motion, once it's economically feasible due to the current lawsuits.

Summary of the assets of the Corporation, including but not limited to its financial, physical, employee, customer, brand or intellectual property, and supply assets:

Financial / Physical: Checking accounts; Buildings; Other Business Ventures

Employees: OSGC has two employees; one full-time and one part-time.

Main Customers: Bellin Health Systems; Schneider National; Badger Sheet Metal Works; United States Postal Services and Oneida Nation.

Summary and status update of any pending legal action to which the Corporation is a party and any relevant government regulation to which the Corporation may be subject:

OSGC has won in the appeal process in the WI State Supreme court against the City of Green Bay regarding our rescinded permit. OSGC is now pursuing all business and legal options to recoup its investment due to the company as a result of illegal revocation of CUP by the City of Green Bay.

OSGC has filed a complaint against the City of Green Bay in an effort to recoup damages suffered from the illegal revocation of the Conditional Use Permit.

Oneida Business Committee Agenda Request

1. Meeting Date Requested: 04 / 27 / 17

2. General Information:

Session: Open Executive - See instructions for the applicable laws, then choose one:

Agenda Header:

Accept as Information only

Action - please describe:

Approval of the Community Development Planning Committee's FY17 2nd Quarter Report

3. Supporting Materials

Report Resolution Contract

Other:

1.

3.

2.

4.

Business Committee signature required

4. Budget Information

Budgeted - Tribal Contribution

Budgeted - Grant Funded

Unbudgeted

5. Submission

Authorized Sponsor / Liaison:

Melinda J. Danforth, Tribal Vice Chairwoman

Primary Requestor/Submitter:

Your Name, Title / Dept. or Tribal Member

Additional Requestor:

Name, Title / Dept.

Additional Requestor:

Name, Title / Dept.

Oneida Business Committee Agenda Request

6. Cover Memo:

Describe the purpose, background/history, and action requested:

Requesting the Business Committee's approval of the Community Development Planning Committee's FY17 2nd Quarter Report

- 1) Save a copy of this form for your records.
- 2) Print this form as a *.pdf *OR* print and scan this form in as *.pdf.
- 3) E-mail this form and all supporting materials in a **SINGLE** *.pdf file to: BC_Agenda_Requests@oneidanation.org

**Community Development Planning Committee
Quarterly Report for FY17 2nd Quarter
January, February and March 2017**

CDPC Members

Melinda J. Danforth, CDPC Chair

Fawn Billie, CDPC Member

Tehassi Hill, CDPC Vice Chair

Jennifer Webster, Member

Lisa Summers, CDPC Member

Brandon Stevens, Alternate

David Jordan, CDPC Member

Purpose

To ensure that the Land Use Plan, Comprehensive Plan, Vision Oneida Plan, Housing Plan, all economic development efforts and land use recommendations are working in coordination with each other to improve the Oneida Tribal community and operations.

Meetings

The CDPC meets every 1st Thursday of the month at 9 a.m. in the Business Committee Conference Room at the Norbert Hill Center. The meeting notice is provided on the Oneida Nation's website.

Activities Summary

CDPC Meeting Dates

January 23, 2017 - Work Meeting

February 2, 2017 – Transition meeting

March 2, 2017

Transition to New BC Administration

CDPC discussed how to transition the new incoming Business Committee Administration. The CDPC and staff will develop recommendations on a transition plan and how to properly convey the projects that are being planned that align with the Comprehensive Plan and Land Use Plan and the status of those plans.

Maple Leaf Project

During this quarter, the financial feasibility of the project continued to be worked on with Finance.

Early Headstart CIP Project

The Oneida Early Headstart CIP Project was placed on hold by the former Governmental Services Division director due to concerns related to federal funding. CDPC requested an update be provided to the full CIP team. As a result of the discussion, the GSD Director requested 60 days to come up with a plan to address the concerns that would have been addressed by this project (i.e. space, access, etc.). It was agreed that if the GSD Director did not provide alternate solutions to the issues, the project would proceed. The new GSD Director reported to the CDPC that the project is supported and will continue to move forward.

Central Oneida/Upper Oneida

The CDPC continues to review the opportunities presented by Oneida Planning to develop Central Oneida, and more particularly the development of Upper Oneida (aka, BP site). The CDPC acknowledges that community input is so vastly different; from green space to community center, restaurants, small business corridor, etc. The CDPC has requested Planning to begin to engage the community to begin narrowing the options for this site.

Guiding Principles for Turtle School to Tsyunhehkwa Corridor in Upper Oneida



- Provide place(s) for community gatherings and activities year round.
- Improve educational opportunities and community connections to Oneida art, language, culture, history, business and agriculture / food systems.
- Restore and connect to natural areas.
- Strengthen and support small business development.
- Reestablish a sense of place to reflect an Oneida “way of life”.
- Safe connections, access and movement to all destinations in Upper Oneida.

Community Interest Survey



focus on the Upper Oneida Corridor
(Turtle School to Tsyunhehkwa)



studio:indigenous
09.07.16

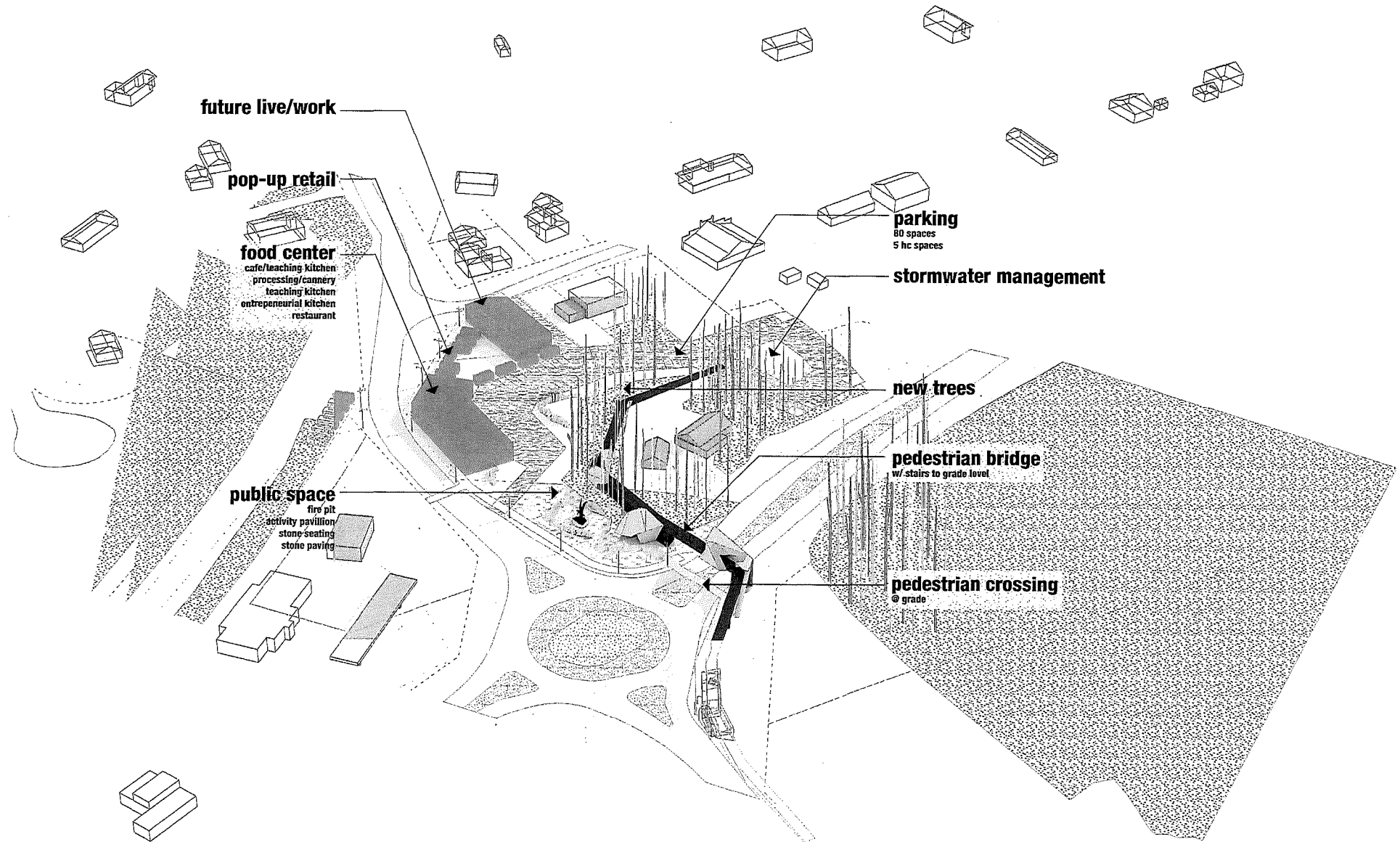

Central Oneida Community Association

**** Meeting****

Wednesday, October 12th at 6pm
At Diane's Bar (Top of the Hill)

Agenda:

- Wolf River Development Co Update (Terry)
- CDPC Oct 6th meeting discussion (Dan)
- Election of COCA officers (all present)
- OSB, Inc. \$500 donation COCA officers (press op)

Contact: oneidasbinc@gmail.com

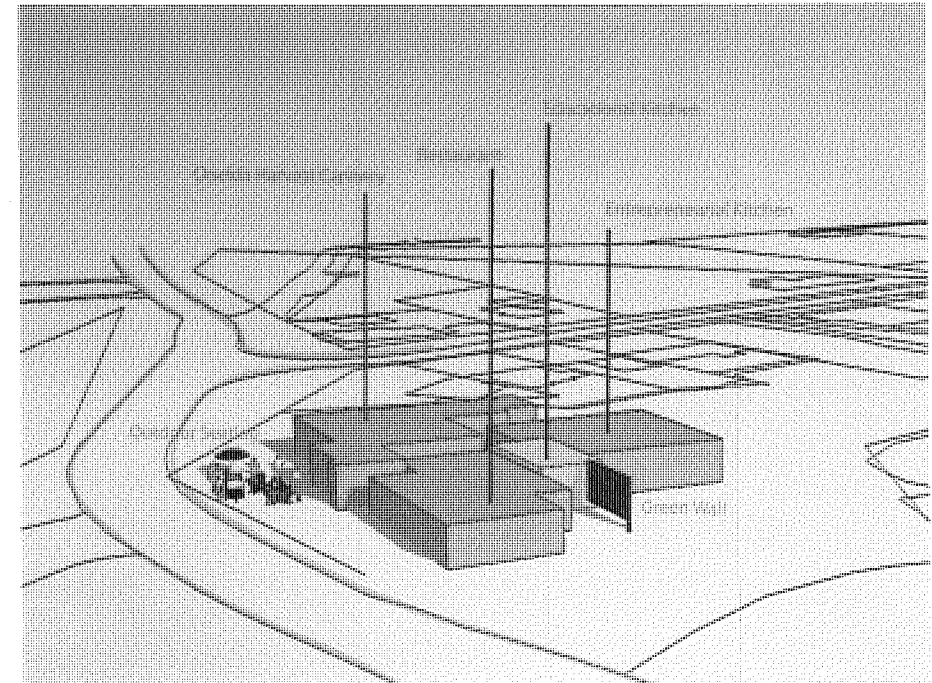

Central Oneida Transportation Hub



Guiding Principles

- Provide place(s) for community gatherings and activities year round.
- Improve educational opportunities in art, language, culture, business and agriculture / food systems.
- Strengthen and support small business development.
- Reestablish a sense of place to reflect an Oneida “ way of life”.
- Safe connections, access and movement to destinations in Upper Oneida.

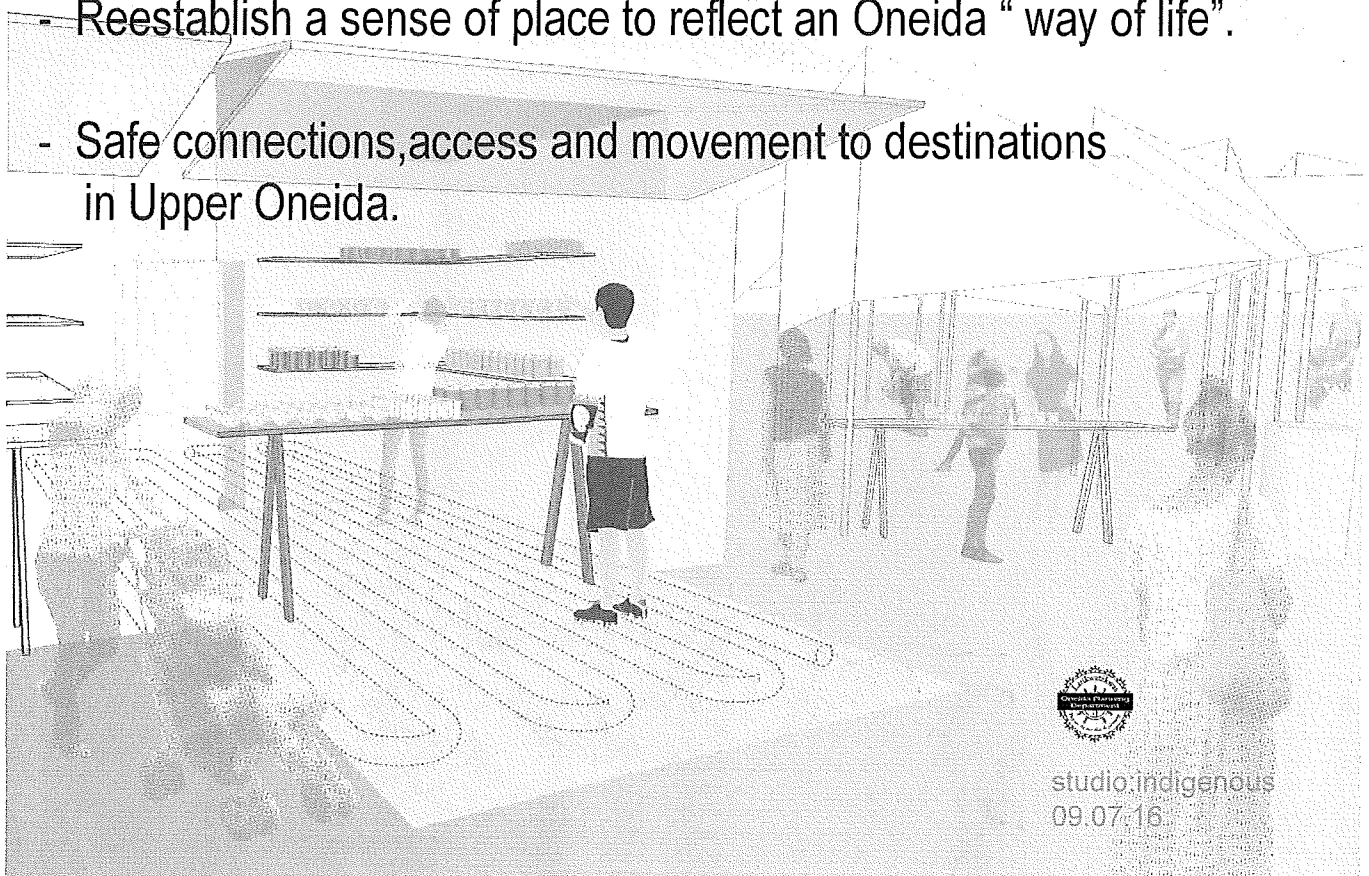

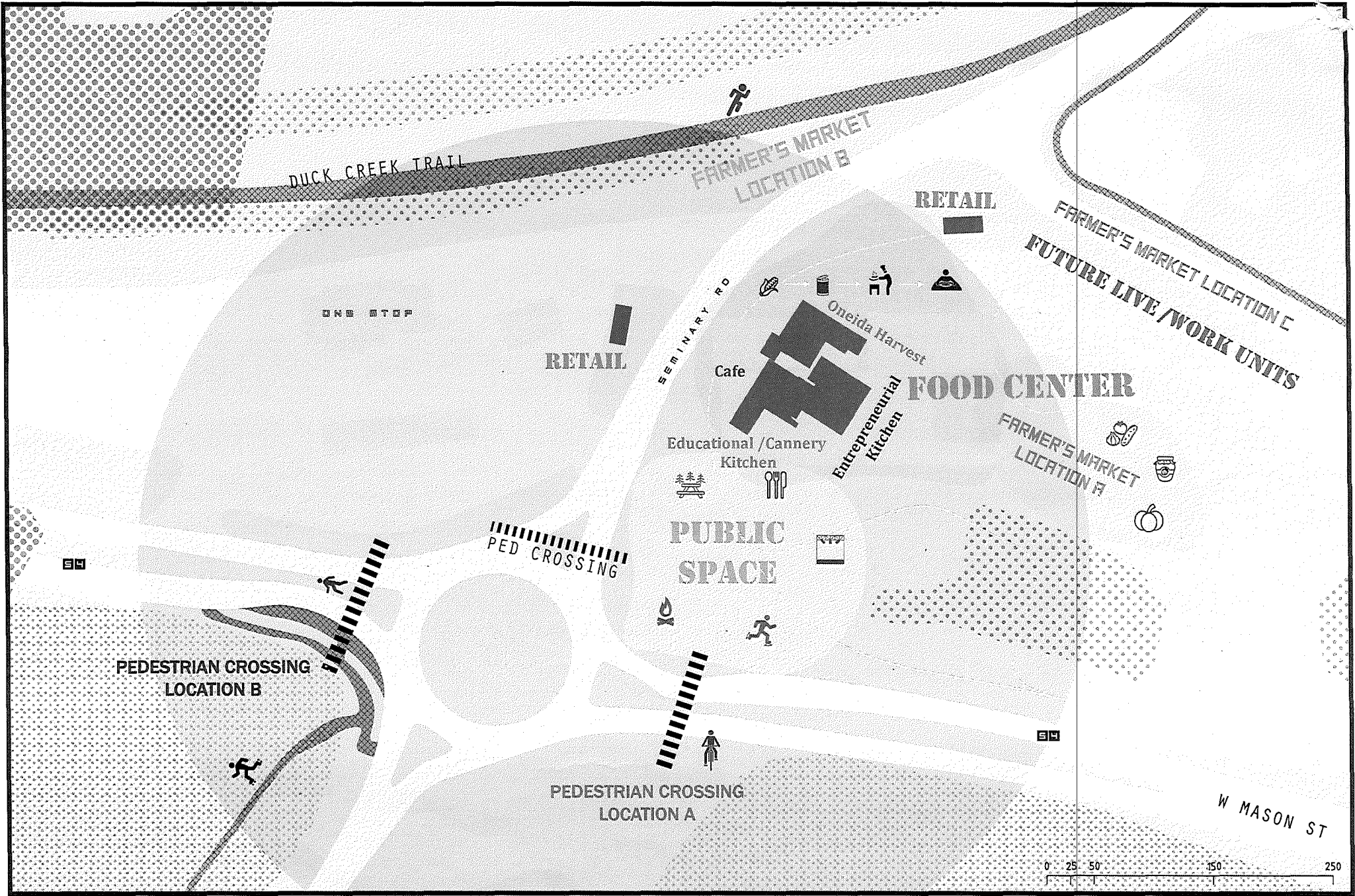

Oneida Business Committee Agenda Request

1. Meeting Date Requested: 04 / 27 / 17

2. General Information:

Session: Open Executive - See instructions for the applicable laws, then choose one:

Agenda Header:

Accept as Information only

Action - please describe:

Approve the Community Development Planning Committee's FY17 1st Quarter Report

3. Supporting Materials

Report Resolution Contract

Other:

1.

3.

2.

4.

Business Committee signature required

4. Budget Information

Budgeted - Tribal Contribution

Budgeted - Grant Funded

Unbudgeted

5. Submission

Authorized Sponsor / Liaison:

Melinda J. Danforth, Tribal Vice Chairwoman

Primary Requestor/Submitter:

Your Name, Title / Dept. or Tribal Member

Additional Requestor:

Name, Title / Dept.

Additional Requestor:

Name, Title / Dept.

Oneida Business Committee Agenda Request

6. Cover Memo:

Describe the purpose, background/history, and action requested:

Requested Action:

Motion to the approve the Community Development Planning Committee's FY17 1st Quarter report.

1) Save a copy of this form for your records.

2) Print this form as a *.pdf *OR* print and scan this form in as *.pdf.

3) E-mail this form and all supporting materials in a **SINGLE** *.pdf file to: BC_Agenda_Requests@oneidanation.org

**Community Development Planning Committee
Quarterly Report for FY17 1st Quarter
October, November and December 2016**

CDPC Members

Melinda J. Danforth, CDPC Chair

Fawn Billie, CDPC Member

Tehassi Hill, CDPC Vice Chair

Jennifer Webster, Member

Lisa Summers, CDPC Member

Brandon Stevens, Alternate

David Jordan, CDPC Member

Purpose

To ensure that the Land Use Plan, Comprehensive Plan, Vision Oneida Plan, Housing Plan, all economic development efforts and land use recommendations are working in coordination with each other to improve the Oneida Tribal community and operations.

Meetings

The CDPC meets every 1st Thursday of the month at 9 a.m. in the Business Committee Conference Room at the Norbert Hill Center. The meeting notice is provided on the Oneida Nation's website.

Activities Summary

CDPC Meeting Dates

October 6, 2016

November 2016 – meeting canceled

December 1, 2016

Blaszyk & Maple Leaf Property Development – Concept

As reported in CDPC's FY16 4th quarter report, the CDPC received a presentation on the concept to develop the former Blaszyk and Maple Leaf properties. The CDPC requested that the team bring back the financials for this project at the February 2, 2017 CDPC meeting.

Attached is the concept presentation received by the CDPC.

Central Oneida Project

The CDPC received a presentation on the Central Oneida project and its relationship to the Comprehensive plan. There are many ideas from the community about how to develop the former BP site and ideas have been proposed by the Planning department; however, no decisions have been made as to what specifically will be done with the site. A special CDPC work meeting is scheduled for Monday, Jan 23rd to review the current proposal and decide how to move forward.

Attached is the presentation received by the CDPC.

Acquaponics Project Update

The CDPC received an update on the Acquaponics project. A \$100,000 grant was received for this initiative. The intent of the aquaponics is to produce salad greens for the Oneida Nation schools, to provide a center for education, and a college semi-credit within NWTC. The location of the project is next to the Oneida Veterans Services Offices so that the veterans could easily volunteer. On September 27, 2016 volunteers from Home Depot assisted with the aquaponics work. The project was scheduled to test on January 15, 2017 and an open house will be held for the Community to see the project in February 2017.

Attached are the updates provided on this project.

Community Recreation Facility

The CDPC began working on reviving the Recreation Facility CIP project that was initially under Governmental Services in 2006. During the first quarter of FY16, the CDPC focused on learning the scope of the previous project in order to determine how to proceed with the project. CDPC determined that CDPC will be the client for this project and will work with the impacted departments and the community to bring forward a CIP package for the Business Committee's consideration.

During the 1st quarter, the Oneida Planning Department continues to work on the Recreation complex from a conceptual planning view. Spring/Summer it is anticipated to gain community input on the project.

Attached is the update received by the CDPC on the project.



notes:

Likes

- _____
- _____
- _____
- _____
- _____
- _____
- _____
- _____

Questions:

- _____
- _____
- _____
- _____
- _____
- _____
- _____
- _____

Maple Leaf: A Mixed-Use Development Concept

Presented to: Community Development Planning Committee December 1, 2016

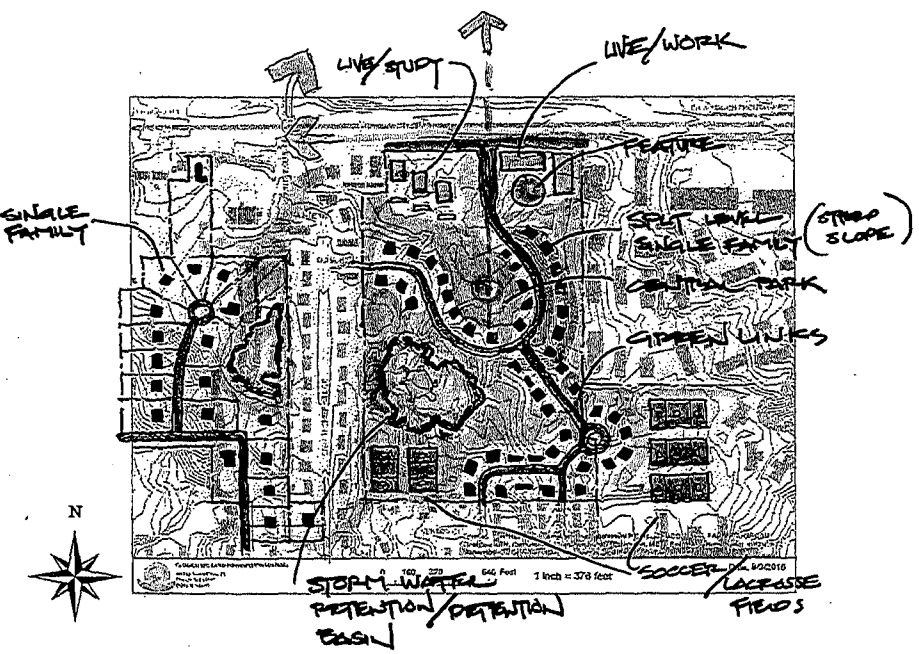

Central Oneida

Guiding Principles for Turtle School to Tsyunhehkwa Corridor in Upper Oneida



- Provide place(s) for community gatherings and activities year round.
- Improve educational opportunities and community connections to Oneida art, language, culture, history, business and agriculture / food systems.
- Restore and connect to natural areas.
- Strengthen and support small business development.
- Reestablish a sense of place to reflect an Oneida "way of life".
- Safe connections, access and movement to all destinations in Upper Oneida.

Community Interest Survey



focus on the Upper Oneida Corridor
(Turtle School to Tsyunhehkwa)

ONEIDA
studio:indigenous
09.07.16

Central Oneida

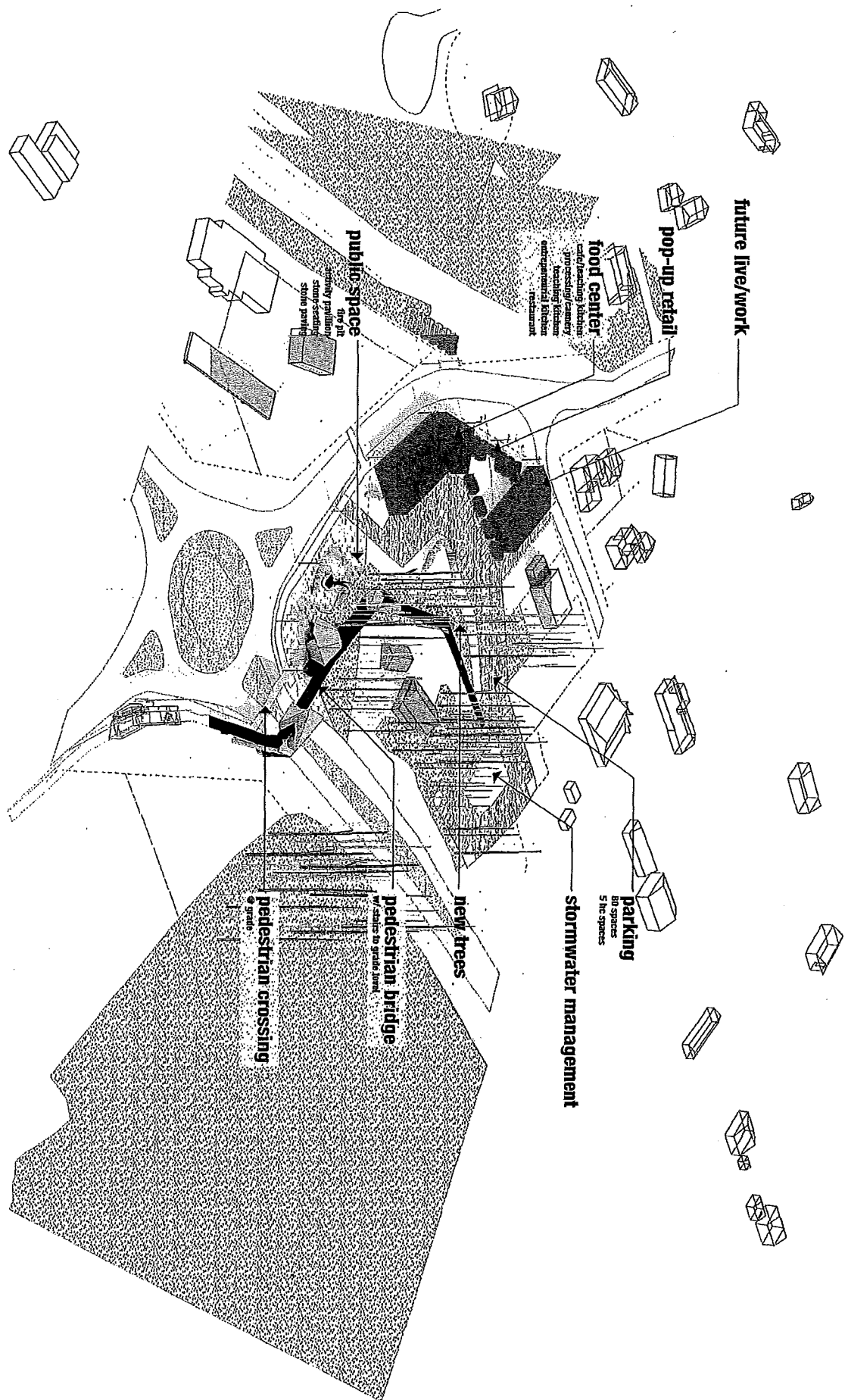

AQUAPONICS

FACT SHEET

Farm to School Grant

Aquaponics

Grant Project

The Farm to School initiative proposes to increase healthy fresh foods for the Oneida tribal school, and expand to surrounding schools, with the development of an 850 sq./ft. aquaponics that can extend the seasons in a region with severe and prolonged winter weather (winter 2014 noted over 45 days of below 0 temperatures, and snow for 5 months).

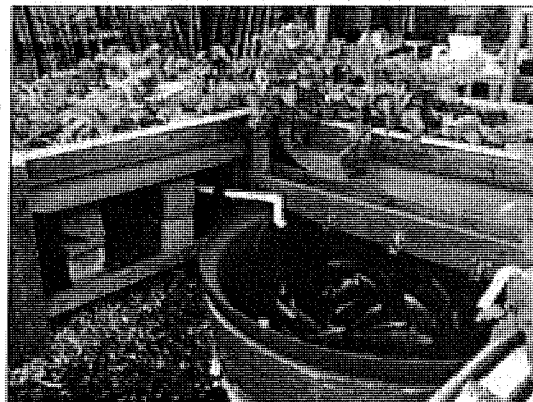

The operational management of the aquaponics system and location is under review to materialize a project for the Veterans as a supplier to the school, and to engage them through this project in educational outreach for the youth and for the community.

The program will equip a used structure with an aquaponics system to produce vegetables and fruit for the Turtle School and High School cafeteria. The program will expand the students' knowledge of healthy foods with an *integrated* approach through *experiential learning activities* such as pick your own at the apple orchard and organic farm, food handling and processing at the cannery, field tours through Youth Day on the Farm and engagement in the Husking Bee (a traditional event of white corn hand-harvesting).



Additionally, Northeast Wisconsin Technical College will develop an *academic curriculum* for the high school seniors on aquaponics and agriculture for college credit. The lower grades will be engaged in learning about healthy foods through the school's science curriculum, and site visits to the aquaponics project. *Family engagement* is another essential component of education on Farm to School, and it will include events such as Apple Fest and the Husking Fest.

The aquaponics system will be capable of annually producing 8600 lbs. of fish and 5,000- 6,900 heads of lettuce (or other vegetables). As a year round system, it will help to bridge the gap during the winter months with fresh produce for the school, and engage community members in its production.

Grant Period

January 2015—December 2016

Project Partners

Oneida Nation: Environmental, Internal Services, Tsyunhehkwa Organic Farm & Cannery, Oneida Veterans, Planning, Oneida School & Northeast Wisconsin Technical College.

Contact

Joanie Buckley jbuckley@oneidanation.org 920-496-7425



Oneida Nation

INTEGRATED FOOD SYSTEMS

January 2015

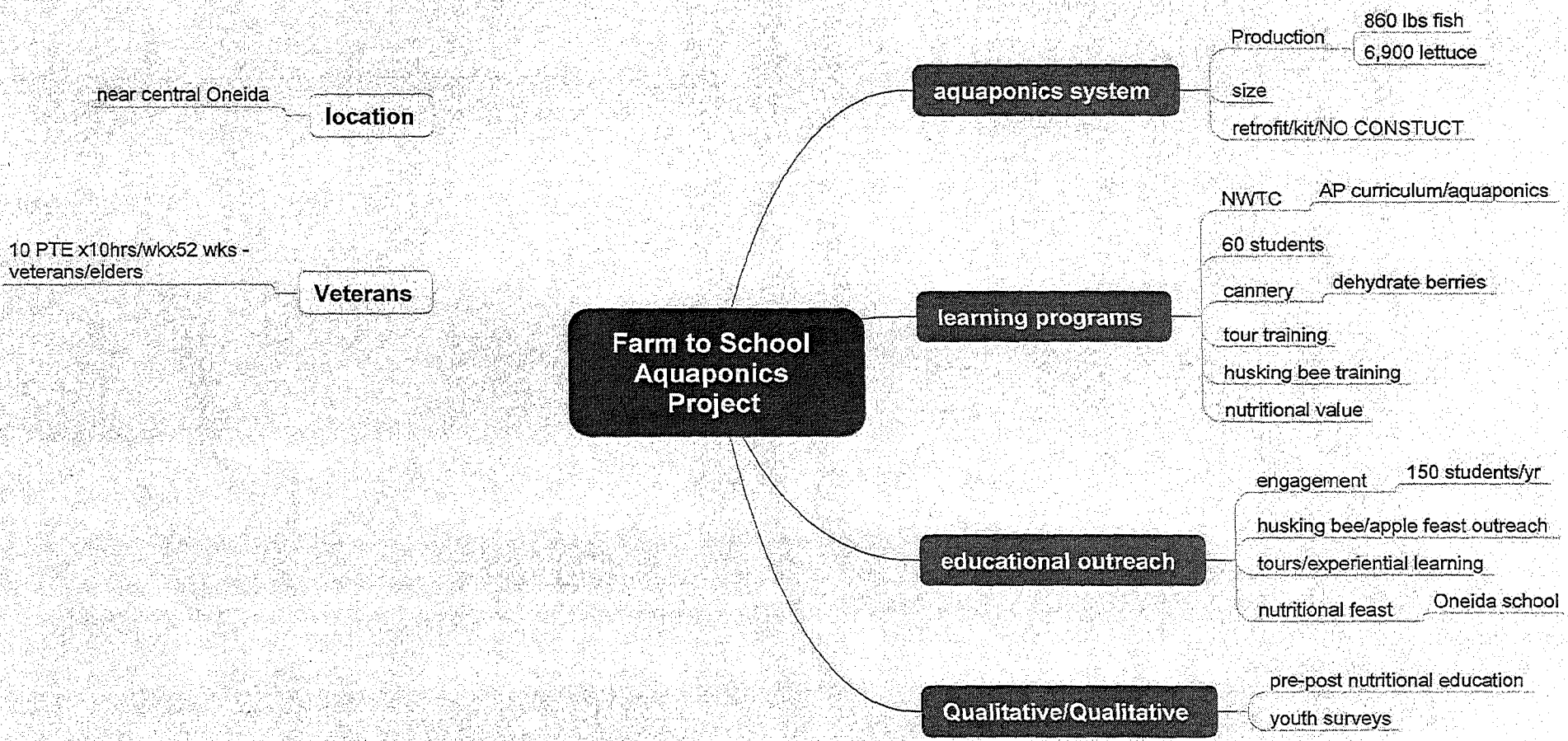

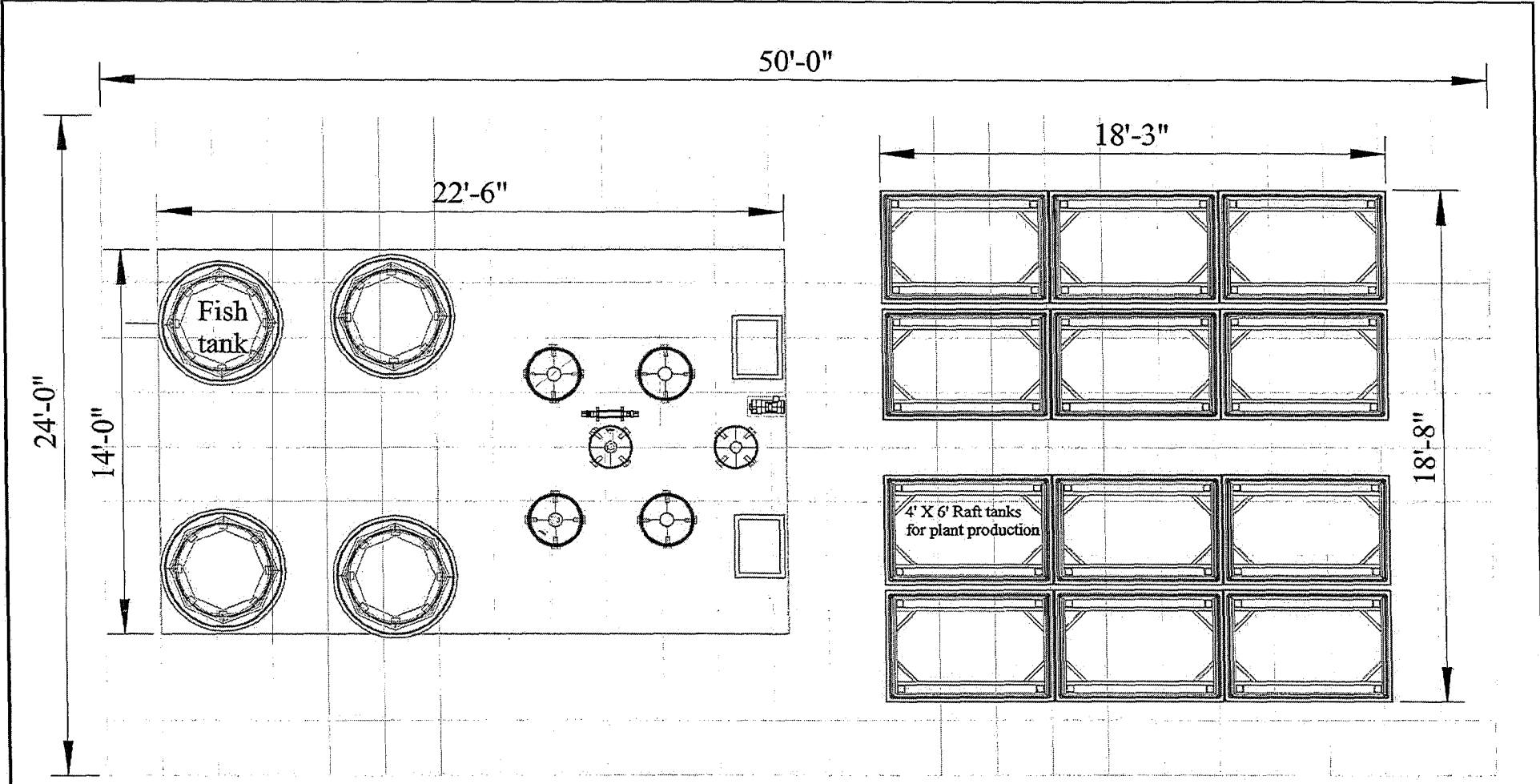

Reference grid spacing = 24" (2')

Nelson Pade[®]
The Most Trusted Name in Aquaponics[®]

Nelson and Pade Inc.
Copyright 2016
For use by recipient only
All rights reserved

4-200 Family Farm Market

Drawn by	RCA	Drawing No.		Date	12/15/15
----------	-----	-------------	--	------	----------

Placement of Accessories:

Below are suggested locations for equipment packs based on the square footage of a greenhouse or shelter.

ATTENTION: It may be necessary to add frame members or change the locations of frame members when adding an equipment pack to an existing greenhouse or shelter.

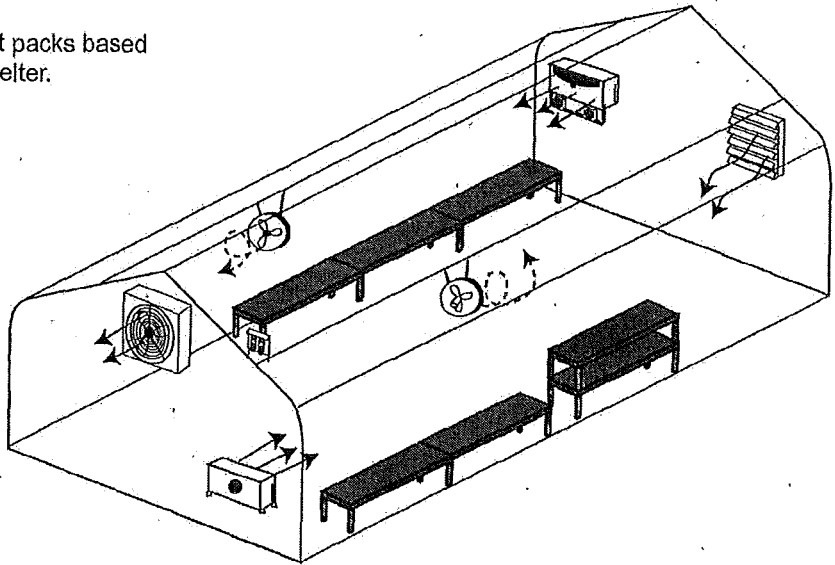

Extra Large Equipment Pack:



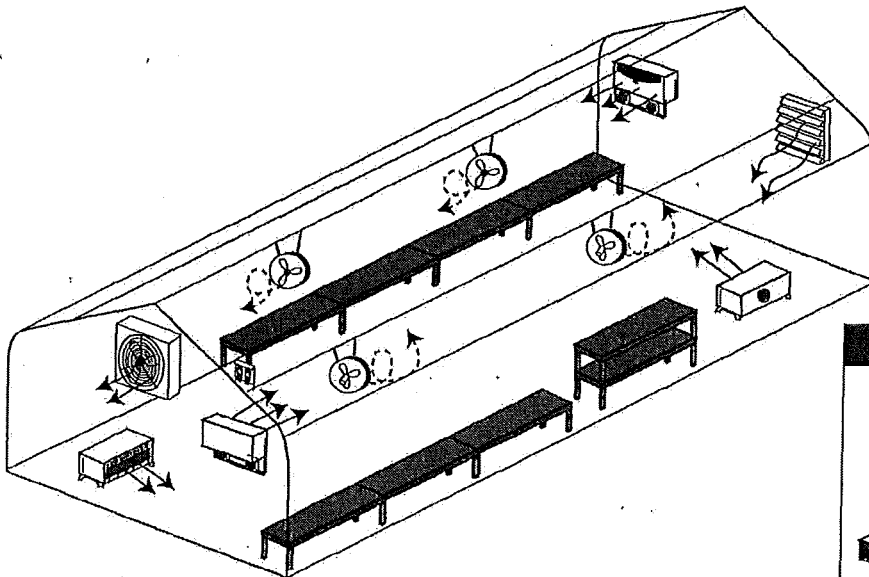







Ideal for shelters and greenhouses with 300-400 square feet, or within any zone where additional heating or cooling is required.

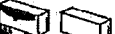

Jumbo Equipment Pack:

Ideal for shelters and greenhouses with 400-700 square feet, or within any zone where additional heating or cooling is required.

Accessory Key

-  Air Circulation Fan
-  Dual Voltage Thermostat
-  Electric Heater
-  Blue Flame Heater (Front and Back View)
-  Blue Flame Heater w/Control Blower (Front and Back View)
-  Direct Vent Heater
-  Direct Vent Heater w/ Blower Kit (Front and Back View)
-  Motorized Intake Shutter
-  Exhaust Fan w/ Shutter
-  2-Tiered Cedar Bench

AQUAPONICS

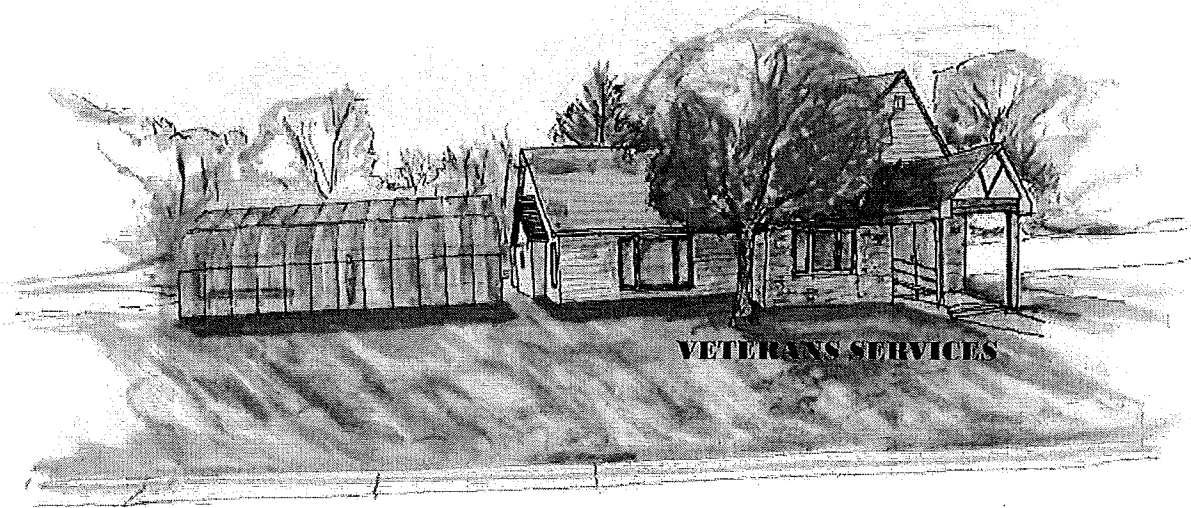

VETERANS SERVICES

FUTURE HOME OF AQUAPONICS SYSTEM

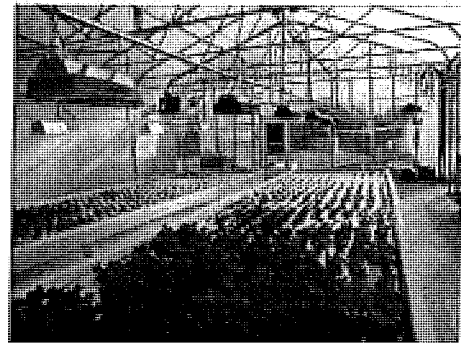
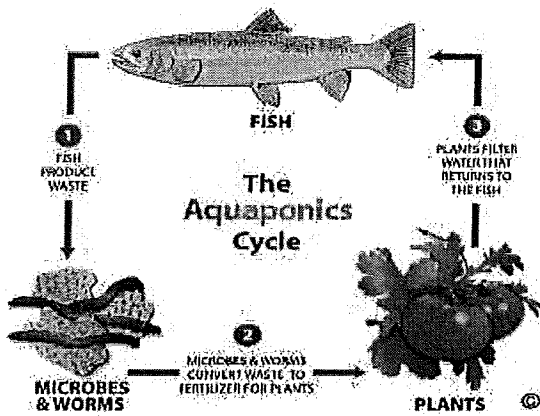

AQUAPONICS

How It Works..

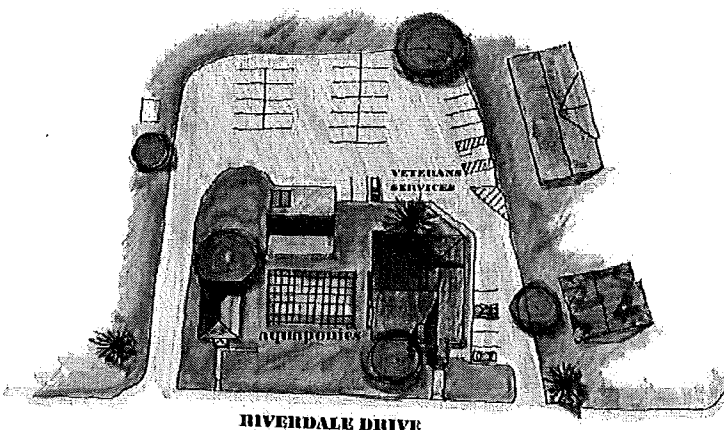

RIVERDALE DRIVE

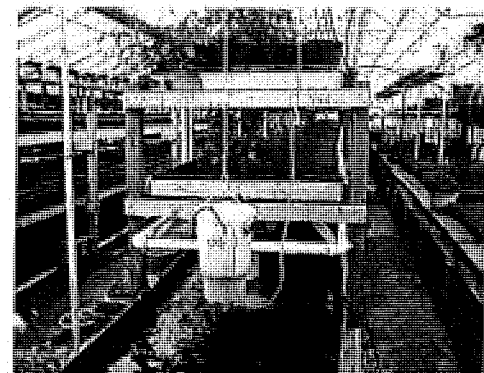

Aquaponics Greenhouse
- Riverdale Drive

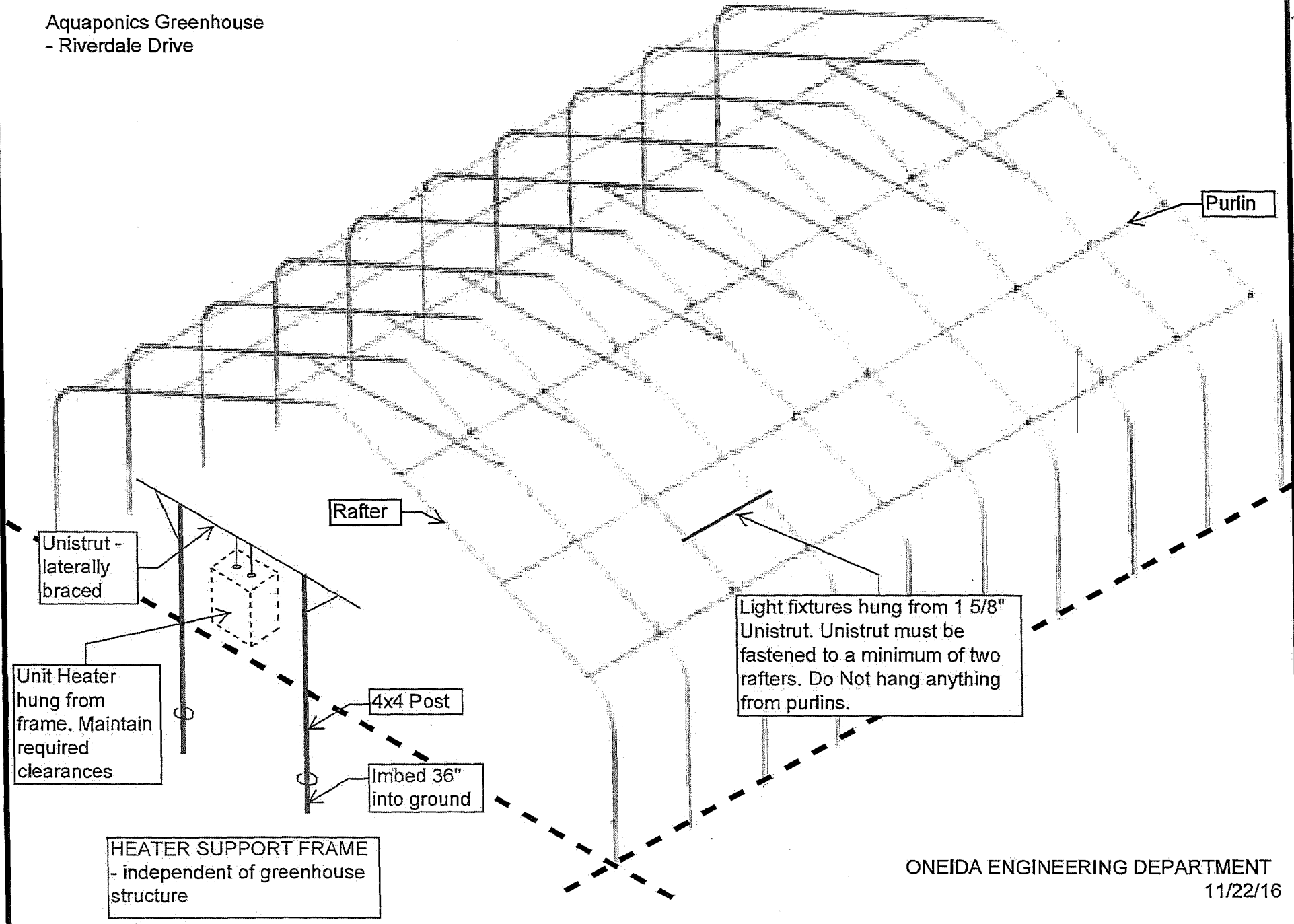

Purlin

Rafter

Unistrut -
laterally
braced

Unit Heater
hung from
frame. Maintain
required
clearances

4x4 Post

Imbed 36"
into ground

Light fixtures hung from 1 5/8"
Unistrut. Unistrut must be
fastened to a minimum of two
rafters. Do Not hang anything
from purlins.

HEATER SUPPORT FRAME
- independent of greenhouse
structure

ONEIDA ENGINEERING DEPARTMENT
11/22/16

Community Rec.

Oneida Tribe of Indians of Wisconsin**PLANNING DEPARTMENT****Location:**

N7332 Water Circle Place
Oneida, WI 54155

Phone: (920) 869-1600

**Mailing Address:**

P.O. Box 365
Oneida, WI 54155-0365

Fax: (920) 869-1610

RE: Community Recreation Facility - January Team Meeting Work Status Report
December 19, 2016

Our current status of work effort for this project is as follows;

- Survey Data - We have completed our analysis of available survey data, identified gaps of relevant information and formulated an approach to update and secure the needed information. We will be working with GSD staff members to review our approach and then prepare the draft survey. Currently we have identified three areas of information of user group information and have designed an approach that will focus on each group through separate surveys. The first group is divisional staff of the key areas of the Tribal organization. These are Health, GSD, and Education. The second area is students and the third area consists of all other tribal members. Further discussion with GSD will help to validate this approach. We have developed the first cut of the first part of the survey and look to start its' implementation after the New Year. After results are returned and analyzed we will formulate a design for the second survey group.
- Potential client perspectives were summarized. We have attempted to meet with the new GSD director, but have been referred to meet with the parks and recreation director. We are working with the parks and recreation staff members collecting information and have solicited input for the development of the survey.
- An analysis of existing facilities was performed in the 1997 Recreational Facility study and this is being updated. Work in this area continues and will be further revisited pending work meetings with GSD staff.
- We have had input meetings with members who are involved in the coordination of community tournaments inclusive of softball, baseball, little leagues, pony leagues, and lacrosse. We anticipate meeting with High School athletic persons for input on outdoor field facilities.
- A preliminary list of similar facilities has been defined with contact persons identified. Preliminary discussions have been initiated with regard to visiting these facilities and gathering pertinent and relevant information. A travel request has been resubmitted however approval has not been granted pending previous reasons.
 - The Kroc Center was visited early December and John Manser, Director of Membership Services provided some good planning and operations information. This included annual maintenance costs and operational costs.

Oneida Recreation Complex #16-011

- Synergy Fields were visited early December to gain an understanding of how an indoor training facility and services could benefit a recreational and sports programs.
- The Ho Chunk Wellness Center and Shakopee Sioux facilities are scheduled to be visited during the week between Christmas and New Years' holiday.

- We anticipate that after our meeting with GSD members and solicitation of survey input we will be stepping up the community input process.

Oneida Business Committee Agenda Request

1. Meeting Date Requested: 4 / 26 / 17

2. General Information:

Session: Open Executive - See instructions for the applicable laws, then choose one:

Agenda Header:

Accept as Information only

Action - please describe:

Approve the LOC FY17 Second Quarter Report

3. Supporting Materials

Report Resolution Contract

Other:

1. <input type="text" value="LOC FY17 2nd Quarter Report"/>	3. <input type="text"/>
2. <input type="text"/>	4. <input type="text"/>

Business Committee signature required

4. Budget Information

Budgeted - Tribal Contribution Budgeted - Grant Funded Unbudgeted

5. Submission

Authorized Sponsor / Liaison:

Primary Requestor/Submitter: Jennifer Falck, LRO Director
Your Name, Title / Dept. or Tribal Member

Additional Requestor: _____
Name, Title / Dept.

Additional Requestor: _____
Name, Title / Dept.



Oneida Nation
 Oneida Business Committee
 Legislative Operating Committee
 PO Box 365 • Oneida, WI 54155-0365
Oneida-nsn.gov



FY17 2nd Quarter Report January 1, 2017- March 31, 2017 Legislative Operating Committee (LOC)

Executive Summary

The second quarter was successful for the Legislative Operating Committee. The Oneida Business Committee was able to adopt two new laws, permanent amendments to six existing laws, and emergency amendments to one existing law. Legislation adopted includes; Oneida Nation Seal & Flag law, Community Support Fund amendments, Tobacco law amendments, Hunting, Fishing, Trapping law amendments, Per Capita law amendments, Budget Management & Control law, Real Property law amendments, Landlord-Tenant emergency amendments, and Conflict of Interest Policy amendments. The LOC also certified two sets of rules per the Administrative Rulemaking Law. Since the 2014-2017 term began, the LOC has completed forty-four (44) legislative items and prepared thirteen (13) Statements of Effect for GTC Petitions. See Table 1 for a summary of the FY17 second quarter agenda items.

The LOC’s third quarter goals are to 1) forward ten (10) items to the Business Committee for consideration, 2) plan for the remainder of this term, and 3) begin to plan for the 2017-2020 administration.

For a complete list of each LOC Members legislative items see Table 3.

Table 1. SUMMARY OF SECOND QUARTER AGENDA ITEMS			
1	Budget Management and Control Law	15	Landlord-Tenant Rule 2
2	Business Committee Meetings Law	16	Legal Resource Center Governing Documents
3	Cemetery Law amendments	17	Mortgage & Foreclosure Law Rule 1
4	Code of Laws Reorganization project	18	Oneida Nation Seal & Flag Law
5	Community Support Fund amendments	19	Per Capita Law amendments
6	Conflict of Interest amendments	20	Petition: Benton-Pre-Employment Drug Testing
7	Drug & Alcohol Free Workplace Policy amendments	21	Petition: Delgado-Panel of Educators & Retention of Kindergarten Students
8	Employment Law	22	Probate Law
9	Endowments Fund amendments	23	Real Property Law amendments
10	Eviction and Termination Rules Extension request	24	Rules of Administrative Procedure
11	Hunting Fishing Trapping Law amendments	25	Tobacco Law amendments
12	Independent Contractor Policy amendments	26	Tribal Criminal Code, Tribal Traffic Code, Tribal Public Peace laws
13	Landlord-Tenant emergency/permanent amendments	27	Tribal Environmental Response
14	Landlord-Tenant rules extension request		

Table 2. MEETINGS HELD IN SECOND QUARTER	
LOC MEETINGS HELD	PUBLIC MEETINGS HELD
January 4, 2017	-Conflict of Interest amendments held on January 3, 2017
January 18, 2017	-Endowments amendments held on February 16, 2017
February 1, 2017	-Drug and Alcohol Free Workplace amendments held on March 2, 2017
February 15, 2017	-Independent Contractor Policy amendments held on March 30, 2017
March 1, 2017	-Cemetery Law Amendments held on March 30, 2017
March 15, 2017	

Featured Legislation: Employment Law

At the request of the Business Committee, the LOC held a second round of Employment Law meetings. In the spring of 2016, 23 meetings were held and 424 employees attended. In January and February of this year, 8 more meetings were held, and 149 employees attended. The LOC has now held a total of 31 employee meetings, and 573 employees attended them.

- Social Services Building, January 30, 2017, 11 attended
- Division of Land Management, February 2, 2017, 19 attended
- Little Bear Development Center, February 6, 2017, 7 attended
- Oneida Health Center, February 6, 2017, 8 attended
- Skenandoah Building, February 9, 2017, 31 attended
- Gaming: Eagle Room, February 9, 2017, Exec. Conference Room (Main Casino), February 13, 2017, 55 attended
- Norbert Hill Center, February 16, 2017, 18 attended

Legislative Reference Office Activities

- Collaborated with Finance Department to develop new fiscal impact statement format and process
- Updated Public Meetings SOP
- Updated LOC Meetings SOP
- Completed Oneida Code of Laws Reorganization Project

Third Quarter Plans

- Complete the Standard Definitions Project
- Send the following items to the OBC for consideration;
 1. Audit Law amendments
 2. Business Committee Meetings Law
 3. Cemetery Law amendments
 4. Domestic Animal Ordinance amendments
 5. Drug & Alcohol Free Workplace Policy permanent amendments
 6. Endowments amendments
 7. Independent Contractor Policy amendments
 8. Landlord-Tenant permanent amendments
 9. Vehicle Driver Certification and Fleet Management Law
 10. GTC Meetings Law

Table 3. LEGISLATIVE OPERATING COMMITTEE: ACTIVE AND COMPLETED ITEMS Last Updated March 21, 2017 Types of Items: N= New Law, A=Amendments, B=Bylaws			
Brandon Stevens, LOC Chair			
Item	Priority	Type	Active/Adoption Date
Administrative Rulemaking Amendments	High	A	Active
Legal Resource Center Law- <i>Emergency</i>	High	N	Active
Business Committee Meetings Law	High	N	Active
Employment Law	High	N	Active
Corporate Laws	High	N	Active
Sanctions & Penalties Law	High	N	Active
Election Board Bylaws Amendments	Low	A	Active
Tribal Criminal Code	Low	N	Active
Administrative Procedures Act Repeal	N/A	N	9/24/2014
Judiciary/Transition Plan Emergency Amendments	N/A	A	09-24-14-P
ONGO Amendments	N/A	A	09-09-15-A
APA Amendments	N/A	A	02-24-16-B
Eviction and Termination	High	N	10-12-16-A
Conflict of Interest	High	A	02-08-17-B
Budget Management & Control	High	N	02-08-17-C
Rules of Administrative Procedure	High	N	Removed 2/15/17

Tehassi Hill, LOC Vice Chair			
Item	Priority	Type	Active/Adoption Date
Workplace Violence Prevention	High	N	Active
Code of Ethics	High	A	Active
Domestic Animals Ordinance	High	A	Active
Law Enforcement Ordinance – Conservation Officers	Low	A	Active
Industrial Hemp Law	Low	N	Active
Tribal Traffic Code	Low	N	Active
Election Law Amendments (On 4/7/17 GTC Agenda)		A	Active
Tribal Environmental Response Program	Medium	A	Active
Leasing Law	High	A	10-26-16-C
Personnel Policies: Job Duties/Work Assignments (Emerg.)	N/A	A	09-24-14-Q
Public Use of Tribal Land (2014)	N/A	A	12-10-14-A
Motor Vehicle Registration	N/A	A	04-22-15-C
Real Property Law Amendments	N/A	A	05-13-15-B
Administrative Rulemaking	N/A	N	02-24-16-C
Election Law Emergency Amendments 2015	N/A	A	06-28-15-A
Tobacco Ordinance Amendments	Medium	A	01-25-17-B
Hunting, Fishing, Trapping Law	High	A	01-25-17-D

Jennifer Webster, LOC Member			
Item	Priority	Type	Active/Adoption Date
Drug & Alcohol Free Workplace for Elected & Appointed Officials (co-sponsor)	High	N	Active
Drug and Alcohol Free Workplace Emergency Amendments (co-sponsor)	High	A	Active
Comprehensive Policy Governing Boards, Committees, & Commissions	High	A	Active
Child Care Consumer Complaint Policy	High	N	Active
Vehicle Driver & Fleet Management	High	N	Active
Audit Law Amendments	High	A	Active
Whistleblower Law	Low	N	Active
Trust/Enrollment Committee Bylaws	Low	B	Active
Tribal Public Peace Law (co-sponsor)	Low	N	Active
Oneida Nation Seal and Flag	High	N	01-11-17-C
Rules of Appellate Procedure Amendments	NA	A	03-25-15-C
Investigative Leave Policy Amendments	NA	A	06-24-15-A
Vendor Licensing Amendments	High	A	10-12-16-E
Fitness for Duty	Medium	N	Removed 02/15/17

Fawn Billie, LOC Member			
Item	Priority	Type	Active/Adoption Date
Higher Education Scholarship	Medium	N	Active
Removal Law	High	A	Active
GTC Meetings Law	High	N	Active
Drug & Alcohol-Free Law for Elected and Appointed Officials (co-sponsor)	High	N	Active
Drug and Alcohol Free Workplace Emergency Amendments (co-sponsor)	High	A	Active
Children's Code	High	N	Active
Research Protection Act	Medium	N	Active
Guardianship Law	Low	N	Active
Personnel Commission Bylaws	Low	B	Active
Severance Law	Low	N	Active
Tribal Public Peace (co-sponsor)	Low	N	Active
Pow-wow Committee Bylaws	N/A	B	04/22/2015
Marriage Law Amendments (2015)	N/A	A	05-27-15-A
Marriage Law Amendments (2016)	N/A	A	05-25-16-A
Furlough Policy	N/A	N	11-10-15-B
Audit Committee Bylaws Amendments	N/A	B	01/20/2016

David Jordan, LOC Member			
Item	Priority	Type	Active/Adoption Date
Professional Conduct for Attorneys and Advocates Law	High	N	Active
Cemetery Law Amendments	High	A	Active
Endowment Fund Amendments	High	A	Active
Nonprofit Incorporation	Medium	N	Active
Rules of Civil Procedure	Medium	A	Active
Compliance and Enforcement Law	Low	N	Active
Secured Transactions	Low	N	Active
Land Commission Bylaws	Medium	B	Active
Landlord-Tenant Permanent Amendments	High	A	Active
Independent Contractor Policy	High	A	Active
Back Pay Amendments	High	A	10-26-16-A
Public Use of Tribal Land Amendments (2016)	N/A	A	01-13-16-C
Mortgage and Foreclosure	High	N	08-10-16-K
Garnishment Amendments	High	A	07-27-16-B
Landlord-Tenant	High	N	10-12-16-C
Community Support Fund Amendments	Medium	A	01-11-17-B
Landlord-Tenant Emergency Amendments	High	A	01-25-17-C
Real Property Amendments	High	A	02-08-17-A
Per Capita Amendments	High	A	02-22-17-D

Oneida Business Committee Agenda Request

1. Meeting Date Requested: 4 / 27 / 17

2. General Information:

Session: Open Executive - See instructions for the applicable laws, then choose one:

Agenda Header: Standing Committees

Accept as Information only

Action - please describe:

Motion to accept the Quality of Life FY17 2nd quarter report.

3. Supporting Materials

Report Resolution Contract

Other:

1. QOL FY17 2nd Quarter Report 3.

2. 4.

Business Committee signature required

4. Budget Information

Budgeted - Tribal Contribution Budgeted - Grant Funded Unbudgeted

5. Submission

Authorized Sponsor / Liaison: Fawn Billie, Council Member

Primary Requestor/Submitter: Cathy Bachhuber, Executive Assistant
Your Name, Title / Dept. or Tribal Member

Additional Requestor: _____
Name, Title / Dept.

Additional Requestor: _____
Name, Title / Dept.

Quality of Life Committee

FY 2017 Quarterly Report (January to March 2017)

PURPOSE

The Quality of Life Committee is a standing committee of the Oneida Business Committee that will have oversight responsibility of the following areas of the Nation: Language and Culture, Health, Human Services and Public Safety. This oversight responsibility also extends to any board, committee, or commission related to these specific areas.

COMMITTEE MEMBERS

Councilwoman Fawn Billie, Quality of Life Committee Chair
Councilman Tehassi Hill, Quality of Life Committee Vice Chair
Treasurer Trish King, Quality of Life Committee Member
Secretary Lisa Summers, Quality of Life Committee Member
Councilman Brandon Stevens, Quality of Life Committee Member

Other partners include: Wellness Council, Oneida Police Department, Division Directors, other senior leaders and their staff

MEETINGS

Quality of Life Committee meetings are held on the second Thursday of every month starting at 8:30 a.m. Two meetings were held in the 2nd quarter on January 12th and March 9th, a meeting was not held in February due to lack of quorum.

ACTIVITIES SUMMARY

A. Increasing Awareness of Drug and Substance Abuse Problems in the Oneida Community

The Quality of Life Committee has partnered with other services and agencies within the Nation to help increase awareness of drug and substance abuse problems in the Oneida Community.

Tribal Action Plan

The Quality of Life received an update on the work of the Tribal Action Plan team, including attending a training workshop geared toward providing tools and resources for the Nation to customize our own Tribal Action Plan to battle drug and substance abuse challenges here in our community.

Youth Risk Survey

Last December, Quality of Life and Wellness Council representatives met with the School Board to discuss the benefits of conducting an existing Youth Risk Survey publically available for use. The School Board will be working on scheduling work meetings to tailor the survey to fit their needs so they can implement the survey at our schools and begin a system of benchmarking any at risk behaviors.

B. Creating Wellness in the Workplace

The Quality of Life Committee is a partner with the Nation's Wellness Council, supporting the Council's efforts to create wellness in the workplace and across the Oneida community.

Exercise at Work Pilot Study

The Quality of Life Committee supported an initiative aimed to identify ways for employees to increase their physical activity while at work to lower health risks, improve morale, and decrease spending on health care.

On March 8, 2017, the BC approved an *Oneida Wellness Council - Exercise at Work Strategy* Resolution #03-08-17-D with an effective date of December 1, 2017. The Wellness Council will be responsible for overseeing the implementation of this initiative.

C. Oneida Services for Tribal Members

The Quality of Life has continued the discussion on how to best coordinate intake client information across various internal departments for those that are disabled and/or handicapped.

REQUESTED ACTION:

To accept the Quality of Life Committee FY2017 2nd quarterly report.

Oneida Business Committee Agenda Request

1. Meeting Date Requested: 04 / 27 / 17

2. General Information:

Session: Open Executive - See instructions for the applicable laws, then choose one:

Agenda Header:

Accept as Information only

Action - please describe:

Accept/approve the Finance Committee FY17 Second Quarter Report.

3. Supporting Materials

Report Resolution Contract

Other:

1.

3.

2.

4.

Business Committee signature required

4. Budget Information

Budgeted - Tribal Contribution Budgeted - Grant Funded Unbudgeted

5. Submission

Authorized Sponsor / Liaison:

Primary Requestor: Denise Vigue, Executive Assistant to the CFO
Your Name, Title / Dept. or Tribal Member

Additional Requestor: _____
Name, Title / Dept.

Additional Requestor: _____
Name, Title / Dept.

Oneida Business Committee Agenda Request

6. Cover Memo:

Describe the purpose, background/history, and action requested:

per the Tribal Secretary's office and Resolution #12-27-16-A, all Boards, Committees, & Commissions are to provide quarterly reports to the OBC

- 1) Save a copy of this form for your records.
- 2) Print this form as a *.pdf *OR* print and scan this form in as *.pdf.
- 3) E-mail this form and all supporting materials in a **SINGLE** *.pdf file to: BC_Agenda_Requests@oneidanation.org



FINANCE COMMITTEE

2nd Quarter Report
(Jan. to Mar. 2017)

Purpose

The Finance Committee is responsible for recommending financial policies and budgets that support the mission, values, and strategic goals of the Nation and organization.

Who We Serve

The Finance Committee works with all departments within the Nation to ensure all expenditures of any substantial amounts are procured in the most cost effective and fair manner as established by the Purchasing Procurement Manual. The FC also serves Oneida Community groups, local charitable organizations, and Oneida members through the Finance Committee Donation Policy and the Community Fund.

Finance Committee Members

Included on the FC are three BC members, one is the Treasurer who chairs the meetings; the Chief Financial Officer who acts as the Vice-Chair; one member from Executive Management; one member from Program Management; and one Community Elder Member.

Second Quarter Meetings

The Finance Committee met six times in Q2 on: Jan. 3rd; 16th; & 30th (for Feb); Feb. 13th; 27th (for Mar.) and Mar. 13, 2017. The FC also held three work meetings on Jan 3rd, Jan. 16th, & Feb. 27th to work on updating the FC By Laws and to work on the CIP/CapEx Contingency Plan. The Community Elder member of the FC attended five meetings (including work meetings) and was paid a stipend of \$250 total for the second quarter.

FY17 Goals

The identified goals as reported in the annual GTC report include:

- 1. Development of several Endowments to meet the cultural, social, educational, and land needs of the Oneida Community;*
- 2. Provide Charitable Giving to the Oneida Community and surrounding areas through the Finance Committee Donation Policy and the Community Fund; and*
- 3. Enhance the effectiveness of the Finance Committee by streamlining internal processes, updating financially related policies and procedures, and creating systematic budget management controls.*

FINANCE COMMITTEE SUMMARY OF SECOND QUARTER ACTIVITIES**▪ REQUESTS FROM THE ORGANIZATION**

Per the Purchasing Procedures, all sole source requests over \$50,000 need Finance Committee Approval. In Q2 the FC reviewed twenty-three (23) Gaming and Department requests for a total approved of \$4,970,239.06. Requests were for Purchase Orders and /or Capital Expenditures for medical supplies, slot machines, insurance premium payments, maintenance agreements, and various consultant contracts. The FC also reviewed eleven (11) FYI items related to slot lease games and government to government agreements.

▪ INVESTMENT UPDATES

There were two update reports provided to the Finance Committee, one on Feb. 13, 2017 for our investment manager from Sage Point and the other on Feb. 27, 2017 from our Chief Financial Advisor.

Sage Point Manager, Scott Webster was present and provided a portfolio of the fourth quarter summary of the investment services Sage Point Financial provides for the Nation. He reviewed the Large Cap diversification and discussed the market and portfolio updates. Conservative investing per the policy resulted in a small growth within market benchmarks; of note was the positive longitudinal return nearly doubling. Terry Cornelius provided an overview of the portfolio by Northern Trust for the FY17 first quarter. He reviewed the quarters' performance of each manager as well as the yearly performance which showed that the managers have done very well when compared to their specific indices; he reviewed several sections of the investments which provided an overall review of all funds; he specifically noted that all funds in this portfolio are not general funds (not liquid) but tribal set asides, with one exception of the STAM account.

▪ DONATIONS

In the Second Quarter the FC reviewed Donation Requests on: Jan. 16th, Feb. 13th, and Mar. 13th, 2017. The FC has designated that they review Community Donation Requests at their second meeting of each month. In Q2 Six (6) Donation Requests were approved for a total expenditure of \$12,058.40. Per the Finance Committee Donation Policy all requests approved represent the following categories: 1) Oneida Community Causes; 2) Local Groups (charitable); and 3) Nation Groups (Indian Affiliated).

The Donation Line total for FY17 was \$49,301; Q1 expenditures of 9417.22 left a balance of \$39,883.78; and Q2 expenditures of \$12,058.40 leaves the Mid-Year balance at \$27,825.38. An attached spreadsheet offers more details.

▪ COMMUNITY FUND

For the Second Quarter, the FC reviewed Community Fund requests for funds and products on Jan. 3rd, Jan. 30th (for Feb) and Feb 27th, 2017 (for March). The FC has designated that they review CF requests at their first meeting of each month. In Q2 five Coca-Cola Product Requests were approved for a total of 175 Cases of Product. All requests were for support of Oneida community events and /or Fundraising events. The FC also approved eighteen (18) funding requests for a total amount of \$3,157. The approved requests went mostly towards youth development activities, such as YMCA swim classes and various sporting activities.

The allocated FY17 amount for the Community Fund was \$50,000 for funding and \$5,000 for products. After Q1 \$45,325 remains for funding and approx. \$3218.84 remains for products. The Mid-Year balances remaining for funds are \$42,168 and \$1783.82 for product. The Q2 CF Listing is attached that offers more details.

DONATIONS: Beginning Balance \$49,301.

Q2	Meeting Date	Name of Requester	Representing	Amount Requested	Reason/Description	Category/ Type	FC Action
1	16-Jan-17	Susan White	Holy Apostles Episcopal Church	\$ 2,500.00	Old Furnace Replacement	2/Church	Approved
2	13-Feb-17	Roland Melchert	Oneida member	\$ 858.40	Honey Bee Production	1/Oneida Comm	Approved
3	13-Mar-17	Tanya Metoxen	Oneida member	\$ 2,500.00	United Tribes for Christ Fellowship International Conference	2/Church	Approved
4	13-Mar-17	David Powless	Oneida member	\$ 2,500.00	Mountain Chief Institute-Spirit of the Hoops July 2017	1/Oneida Comm	Approved
5	13-Mar-17	Shad Webster	Oneida member	\$ 1,200.00	Indigenous Games 2017 -Team WI Archery Team	1/Oneida Comm	Approved
6	13-Mar-17	Brian Jackson	Tribal Organization in Wisconsin	\$ 2,500.00	Wisconsin Indian Education Association	3/National Tribal Affl Grp	Approved

FC Donation Totals After First Quarter

Designations /Percentages	Allocation Per Category	Expenditures	Remaining Balance
1. Oneida Community Causes - 40%	\$19,720.40	\$917.22	\$18,803.18
2. Local Groups (Charitable) - 40%	\$19,720.40	\$5,000.00	\$14,720.40
3. Nat'l Grps (Indian Affil) - 20%	\$9,860.20	\$3,500.00	\$6,360.20
	\$49,301.00	\$9,417.22	Balance after Q1 \$39,883.78.

FC Donation Totals After Second Quarter

Designations /Percentages	Balance from Q1	Expenditures	Remaining Balance
1. Oneida Community Causes - 40%	\$18,803.18	\$4,558.40	\$14,244.78
2. Local Groups (Charitable) - 40%	\$14,720.40	\$5,000.00	\$9,720.40
3. Nat'l Grps (Indian Affil) - 20%	\$6,360.20	\$2,500.00	\$3,860.20
	\$39,883.78	\$12,058.40	Mid-Year Balance \$27,825.38

Requests reviewed from Not-for-Profits, Oneida Affiliated Vets Grps, Socially/Enviro Conscious Grps, & Spl Funded

FY17 Finance Committee - 2nd Quarter Activities
for the Community Fund

	FC Mtg Date	Requestor	Reason/Description of Request	CF Category	Approved Amt
1	3-Jan-17	Margaret VandenHeuvel	YMCA Swin lessons for son	SD-Youth	\$ 62.00
2	3-Jan-17	Margaret VandenHeuvel	YMCA Swin lessons for son	SD-Youth	\$ 62.00
3	3-Jan-17	Margaret VandenHeuvel	YMCA Swin lessons for son	SD-Youth	\$ 62.00
4	30-Jan-17	Christine Klimmek	Watercolor Class	SD-Adult	\$ 200.00
5	30-Jan-17	Wendy Alvarez	March of Dimes Pancake fundraiser	CommFundr	5 Cases
6	30-Jan-17	Jacqueline Schuman	Green Bay Elite Cheer fees for daughter	SD-Youth	\$ 200.00
7	30-Jan-17	Kateri Danforth	STARZ Academy class fees for daughter	SD-Youth	\$ 200.00
8	30-Jan-17	Kateri Danforth	Karate USA class fees for son	SD-Youth	\$ 200.00
9	30-Jan-17	Timothy Ninham	Purple Aces AAU Basketball fees for daughter	SD-Youth	\$ 200.00
10	30-Jan-17	Kana Zacarias Skenandore	YMCA swim lessons for daughter	SD-Youth	\$ 200.00
11	30-Jan-17	Kana Zacarias Skenandore	YMCA swim lessons for daughter	SD-Youth	\$ 200.00
12	30-Jan-17	Kana Zacarias Skenandore	YMCA swim lessons for daughter	SD-Youth	\$ 200.00
13	30-Jan-17	Kana Zacarias Skenandore	YMCA swim lessons for daughter	SD-Youth	\$ 200.00
14	27-Feb-17	Katsi Danforth	YMCA classes for daughter	SD-Youth	\$ 200.00
15	27-Feb-17	Jessica Pesche	AFW Elite team trip fees for son	SD-Youth	\$ 200.00
16	27-Feb-17	Tonya Webster	Oneida Annual Powwow	ComEvt-Fundr	100 Cases
17	27-Feb-17	Abby Danforth	Holy Apostles Fish Fry Fridays	ComEvt-Fundr	25 Cases
18	27-Feb-17	Lisa Rauschenbach	Wisconsin Blizzard fees for son	SD-Youth	\$ 200.00
19	27-Feb-17	Vashi L. Cornelius	GYMACT Gymnastics for daughter	SD-Youth	\$ 200.00
20	27-Feb-17	Paula King-Dessart	Relay for Life Oneida	ComEvt-Fundr	20 Cs from CY17-18
21	27-Feb-17	Scott Webster	AP Test Registration for son	SD-Youth	\$ 171.00
22	27-Feb-17	Carolyn Miller	Daniel Jourdan Cancer Benefit	ComEvt-Fundr	\$ 200.00
23	27-Feb-17	Carolyn Miller	Daniel Jourdan Cancer Benefit	ComEvt-Fundr	20 Cases
24	27-Feb-17	Daniel Skenandore	AO-Hillcrest School Family Fun Night	ComEvt-Fundr	25 Cases



M E M O R A N D U M

TO: Oneida Business Committee

FROM: Jo Anne House, Chief Counsel

DATE: April 24, 2017

SUBJECT: Opinion – Personnel Commission Report – Confidential Information

You have requested a legal opinion regarding a quarterly report submitted by the Personnel Commission. The Oneida Business Committee has identified that the report contains statements about personnel or personnel actions that should not be presented in open session. The report has been continuously rejected by the Oneida Business Committee and the Personnel Commission has identified that it will not change or redact the report in order for it to be accepted as a public document. You have requested advice regarding the actions that could be taken to have the report accepted.

Under the Open Records and Open Meetings law personnel actions are exempt from public meeting discussion. This is consistent with resolution # BC-08-14-91-A and the directive in the Personnel Policies and Procedures that employment related information is confidential. As a result, it is appropriate that the Oneida Business Committee not accept a report containing restricted information.

There are three basic options available to the Oneida Business Committee.

- ***Continue to reject the report.***
You have identified that this option is not acceptable on a long term basis.
- ***Place the entire report in Executive Session.***
Although this will resolve the issue regarding confidential information, most of the report can be presented in open session. This is likely to be in violation of the Open Records and Open Meetings law.
- **Redact that portion of the report and place report in Open Session.**
The Oneida Business Committee is the ‘owner’ of documents placed on its agenda. As a result, it would be my opinion that you could simply black-out that portion of the report and place a footnote on the document indicating “This portion of the report has been redacted as it contains confidential/personnel related information.” The suggested approval action would be “Motion to accept the Personnel Commission ___ Quarter report and to direct that the report be placed in the record as redacted.”

If you have further questions, please contact me.

Oneida Business Committee Agenda Request

1. Meeting Date Requested: 01 / 25 / 17

2. General Information:

Session: [X] Open [] Executive - See instructions for the applicable laws, then choose one:

[Empty text box]

Agenda Header: Reports

[] Accept as Information only

[] Action - please describe:

Acceptance of 1st Quarter Report for the Oneida Personnel Commission
October 2016-December 2016

3. Supporting Materials

[X] Report [] Resolution [] Contract

[] Other:

1. minutes

3. [Empty text box]

2. R & E's

4. [Empty text box]

[] Business Committee signature required

4. Budget Information

[] Budgeted - Tribal Contribution

[] Budgeted - Grant Funded

[] Unbudgeted

5. Submission

Authorized Sponsor / Liaison: David Jordan, Council Member

Primary Requestor/Submitter: Yvonne Jourdan, Chairwoman, Oneida Personnel Commission
Your Name, Title / Dept. or Tribal Member

Additional Requestor:
Name, Title / Dept.

Additional Requestor:
Name, Title / Dept.

HANDOUT FOR ITEM - IV.A.06.a.

ONEIDA PERSONNEL COMMISSION
FY 2017- Quarterly Report First Quarter
October, November and December 2016
Submitted by: Yvonne Jourdan

NAMES

Officers: Yvonne Jourdan, Chairperson
Gary Smith, Vice-Chairperson
Sharon Alvarez, Treasurer
Tomas Escamea, Secretary

Members: Bradley Graham
Richard Elm-Hill
Jennifer Hill
Leland Wigg-Ninham
Eric Krawczyk
Pearl Webster
Carol Smith

MINUTES

All approved minutes have been submitted to the Office of the Tribal Secretary.

October 18, 2016	Regular Meeting	(Approved)
November 15, 2016	Regular Meeting	(Approved)
November 16, 2016	Emergency Meeting	(Approved)
December 20, 2016	Regular Meeting	(Not Approved)

FINANCIAL

See attached R&E statements for the months of October, November and December 2016.

SPECIAL EVENTS AND TRAVEL

No out-of-state travel/training occurred during this quarter.

LOCAL TRAINING

Training for the first quarter of this fiscal year included standard initial reviews, grievance hearings, and grievance decisions training which took place in October, November and December.

ACTIVITY REPORT-Oneida Personnel Commission

Activity	October	November	December	Totals
Pre-Screens	26	14	17	57
Interviews	20	18	18	56
Reassignments	9	10	9	28
Initial Reviews	2	2	3	7
Grievances	2	2	1	5
Deliberations	4	0	2	6

HANDOUT FOR ITEM - IV.A.06.a.

Decision Writing	2	1	2	5
Motion Decisions	1	0	1	2
Regular Meetings	1	1	1	3
Special Meetings	0	1	0	1
Training*	6	2	2	10
Non-Gaming Employees with an advocate	1	0	1	2
Non-Gaming Employees without an advocate	0	1	1	2
Gaming Employees with an advocate	1	0	0	1
Gaming Employees without an advocate	0	1	0	1
Non-Gaming Management with an advocate	0	0	0	0
Non-Gaming Management without an advocate	1	1	2	4
Gaming Management with an advocate	1	1	0	2
Gaming Management without an advocate	0	0	0	0

- The numbers within the Reassignment boxes, are the numbers of employees that were reassigned into different positions for that specific month.

Training could mean attending out-of-state, local training, or in-house training. New commissioners are mentored by existing commissioners during Initial Reviews, Grievance Hearings, Decision Writing, Hearing Officer Responsibilities, and Motion Decisions. This type of involvement is also considered training.

PERSONAL COMMENTS - Yvonne Jourdan, Chairperson - OPC

This Commission has continued to review the proposed Employment Law (draft #21), that is currently at the Legislative Operating Committee (LOC). We have taken the position that this new Law is not favorable to the employment base. Although there have been numerous changes to each draft, one of the issues that this Commission has is that the main area that contributed to the drafts of this proposed law has been the Human Resource Department.(HRD) The proposed law allows HRD to make changes to a proposed law that ultimately affects HRD and provides enormous latitude in the hiring process with absolutely no checks or balances. As a Commission that has been created by General Tribal Council, this is a serious concern. On December 8, 2016, this Commission received notice from Geraldine Danforth, HRD Area Manager, and Marianne Close, Compensation and Employment Director that they will now be reporting in their

quarterly reports, Personnel Commission attendance, late/tardy, failed to show, didn't notify HR and didn't find a replacement. This Commission will be reporting to General Tribal Council, the same with regard to overbooking Commissioners, not calling Commissioners, failure to ensure interview and pre-screening is in compliance with the Oneida Tribes Blue Book, unusual or deviation from the hiring process without justification. Concerns, on November 9, 2016, two new Commissioners were scheduled for interview certification, the place of training was changed without any notice to the Commissioners, forcing those two Commissioners to wait an additional 3 months to receive this training. Additionally on November 3, 2016, an HRD specialist over booked a Commissioner for interviews and provided him with the wrong dates for interviews, thus causing an extra stipend to be paid for those interviews. On December 22, 2016, there was a second prescreening for a position where prescreening was originally conducted on December 16, 2016. The HRD specialist had prescreened on her own, prior to informing the assigned OPC Commissioner, and scheduled interviews with the potential candidates prior to having the Commissioner prescreen the position for a second time. This is unusual due to the fact that prescreening applicants does not occur minutes prior to the interviews. No justification or rationale has been provided as to why this was initiated by HRD.

We have taken the position that we would inform General Tribal Council (G.T.C) of the Commission's perspective and bring awareness to both G.T.C. and the employment base, we are doing this through our articles placed in our Tribal newspaper. This Commission has requested verbally that once the Oneida Business Committee establishes a date for General Tribal Council to meet and decide whether or not they support this Law, we would like to present our perspectives, issues and concerns regarding the proposed Employment Law.



The Commission continues to review current policies that have been approved and passed by the Oneida Business Committee (OBC) along with the Human Resource Department,(HRD) with the expectation that there can be improvements and discussion with both the OBC and HRD. The Personnel Commission continues to review the by-laws, SOP's, and the training manual for accuracy and relevance to the laws and policies of the Oneida Tribe. We have completed work on updating the qualifications for future Commissioners, which will be reflected in our By-Laws, and are currently pending at the LOC. In the future Quarterly reports, starting with the first Quarter of FY 2017, this Commission will report inconsistencies in the application of policies and procedures regarding hiring practices within HRD, this will include grievance matters that have come before this Commission.

GOALS AND OBJECTIVES – FY2017

1. Personnel Commission By-Laws	REVISIONS
2. Training Manual	IN PROGRESS
3. Updating Qualifications for Commissioners	REVISIONS PENDING AT LOC
3. Interdepartmental Relationships	NEEDS IMPROVEMENT
4. Updating Personnel Commission SOP's	IN PROGRESS

OBJECTIVE STATEMENT – FY 2017

1. Optimize organizational efficiency and effectiveness
2. Learning and growth perspective
3. Owner/customer/stakeholder perspective

MEETING REQUIREMENTS

Oneida Personnel Commission By-Laws, Article III. Meetings.

3-1 *Regular Meetings.* The OPC officers shall establish a schedule of regular meetings for the upcoming year beginning in November. Notice of meeting location, agenda and materials shall be forwarded by the Chairperson with the assistance of the Administrator. Robert's Rules of Order shall be used as a guideline for conducting meetings.

3-2 *Special Meetings.* Special meetings shall be called not less than three (3) days prior to the date of the special meeting.

3-3. *Emergency meetings.* Emergency meetings shall be scheduled as needed and provide details of the emergency.

3-4 *Legislative Sessions.* When considering revisions or suggestions to the OPC regarding the labor laws of the Tribe, a Legislative Session may be scheduled to devote a focused exclusive convened working meeting of the OPC to specifically address amendment or revision of existing or proposed labor laws of the Tribe. An internal OPC SOP may be drafted governing the procedures to be followed in implementing such Legislative Session.

3-5 *Quorum.* A quorum shall consist of a majority of the OPC members. In the absence of the Chairperson and the Vice-Chairperson, the members present at the meeting shall elect a Chairperson *Pro Tem* to preside over the meeting.

FOLLOW-UP

- Meeting with the Personnel Commission's alternate Liaison, David Jordan, Tribal Councilman, regarding issues and concerns of the Commission.

HANDOUT FOR ITEM - IV.A.06.a.

ONEIDA PERSONNEL COMMISSION REGULAR MEETING

October 18, 2016 – NOON
East Wing Conference Room

Mission Statement: To develop an employment system that is orderly and fair and one that will benefit the individual worker and strengthen Tribal Programs and Tribal Government.

Secretary: Rochelle A. Powless (NOT PRESENT)

- A. Call to Order: Attendance (12:00p.m.) Gate Keeper: Yvonne Jordan, Chairwoman, called the meeting to order at 12:00p.m.

Yvonne Jourdan	Chairwoman
Gary Smith	Vice-Chair
Sharon Alvarez	Treasurer
Carol Smith	Member
Tomas Escamea	Member
Bradley Graham	Member
Pearl Webster	Member
Eric Krawczyk	Member
Jennifer Hill	Member
Leland Wigg-Ninham	Member

Also Present:

Gina Buenrostro	Administrator
Bridget Cornelius	Executive Assistant
Robert Sweeney	Attorney
David Jordan	OBC Liaison

EXCUSED:

Rochelle A. Powless	Secretary
---------------------	-----------

MOTION: Bradley Graham motioned to approve the attendance excusing Rochelle

SECOND: Sharon Alvarez seconded the motion.

MOTION CARRIED UNANIMOUSLY

- B. Approval of Agenda (5 minutes)

MOTION: Bradley Graham motioned to approve the agenda with changes:

New Business – Delete F.1.b

SECOND: Pearl Webster seconded the motion.

MOTION CARRIED UNANIMOUSLY

- C. Review\Approval of Minutes: September 20, 2016, OPC Regular Meeting
(Rochelle Powless 10 minutes)

MOTION: Bradley Graham motioned to approve the September 20, 2016, OPC Regular Meeting Minutes, with corrections.

SECOND: Sharon Alvarez seconded the motion.

HANDOUT FOR ITEM - IV.A.06.a.

ONEIDA PERSONNEL COMMISSION REGULAR MEETING

October 18, 2016 – NOON

East Wing Conference Room

MOTION CARRIED UNANIMOUSLY

D. Tabled Business (none)

E. Old Business (4)

1. Draft article for the Kahliwisaks (entire commission 10 minutes)
FYI, update was given, Commissioner were sent email correspondence regarding this issue, deadline for response is October 25, 2016
2. **Internal Audit Request-UPDATE**
No Update
3. **Employment Law Draft 21-UPDATE**
No Update, draft was distributed
4. **Status of Complaint regarding the Area Manager of Fitness, Parks and Recreation-Update-(Entire Commission)*Carol Smith recused herself from discussion*****

MOTION: Bradley Graham moved to go into executive session

SECOND: Pearl Webster

TIME: 12:48PM

MOTION CARRIED UNANIMOUSLY

MOTION: Eric Krawczyk moved to come out of executive session

SECOND: Gary Smith

TIME: 1:16PM

MOTION CARRIED UNANIMOUSLY

MOTION: Gary Smith moved to submit a letter to the Pro-Tem Commission assigned to this case and request documents, testimony, evidence as protected information.

SECOND: Leland Wigg-Ninham

OPPOSED: Bradley Graham

MOTION CARRIED

F. New Business(4)

1. **Scheduling Initial Reviews, Grievances, Reassignments and Housekeeping-(Gina Buenrostro 10 minutes)**

MOTION: Bradley Graham motioned to go into executive session

SECOND: Pearl Webster Time: 1:23PM

MOTION CARRIED UNANIMOUSLY

MOTION: Eric Krawczyk motioned to come out of executive session

SECOND: Tomas Escamea Time: 1:30PM

MOTION CARRIED UNANIMOUSLY

HANDOUT FOR ITEM - IV.A.06.a.

ONEIDA PERSONNEL COMMISSION REGULAR MEETING

October 18, 2016 – NOON
East Wing Conference Room

a. Resignation of Rochelle Powless

MOTION: Eric Krawczyk moved to accept the resignation of Rochelle Powless.

SECOND: Carol Smith

MOTION CARRIED

MOTION: Bradley Graham moved to send notice to the Oneida Business Committee to post this vacancy

SECOND: Pearl Webster

MOTION CARRIED UNANIMOUSLY

b. Request from Leland Wigg-Ninham to waive training

DELETED FROM AGENDA

c. 3rd Quarterly Report-status

MOTION: Bradley Graham moved to post both the Quarterly report, 2nd and 3rd quarter, in the Kahliwisaks to apprise General Tribal Council of the reports.

SECOND: Pearl Webster

ABSTAIN: Carol Smith

MOTION CARRIED

2. Financial Report August 2016

MOTION: Gary Smith motioned to approve

SECOND: Bradley Graham seconded the motion.

MOTION CARRIED UNANIMOUSLY

3. Activity Report August 2016

MOTION: Gary Smith motions to approve

SECOND: Carol Smith

MOTION CARRIED UNANIMOUSLY

4. By-Laws

MOTION: Tomas Escamea moved to approve and send to the LOC

SECOND: Sharon Alvarez

MOTION CARRIED UNANIMOUSLY

MOTION: Gary Smith moved to adjourn

SECOND: Carol Smith

MOTION CARRIED UNANIMOUSLY

HANDOUT FOR ITEM - IV.A.06.a.

ONEIDA PERSONNEL COMMISSION REGULAR MEETING

October 18, 2016 – NOON
East Wing Conference Room



Minutes taken for the secretary by Gina Buenrostro

HANDOUT FOR ITEM - IV.A.06.a.

ONEIDA PERSONNEL COMMISSION REGULAR MEETING

November 15, 2016 – NOON

East Wing Conference Room

Mission Statement: To develop an employment system that is orderly and fair and one that will benefit the individual worker and strengthen Tribal Programs and Tribal Government.

Secretary:

- A. Call to Order: Attendance (12:00p.m.) Gate Keeper: Yvonne Jordan, Chairwoman, called the meeting to order at 12:02p.m.

Yvonne Jourdan	Chairwoman
Gary Smith	Vice-Chair
Sharon Alvarez	Treasurer
Carol Smith	Member
Tomas Escamea	Member
Bradley Graham	Member
Pearl Webster	Member
Jennifer Hill	Member

Also Present:

Gina Buenrostro	Administrator
Bridget Cornelius	Executive Assistant
Robert Sweeney	Attorney
David Jordan	OBC Liaison

EXCUSED:

Eric Krawczyk	Member
---------------	--------

UNEXCUSED:

Leland Wigg-Ninham Member

MOTION: Bradley Graham motioned to approve the attendance excusing Eric Krawczyk and unexcusing Leland Wigg-Ninham.

SECOND: Tomas Escamea seconded the motion.

MOTION CARRIED UNANIMOUSLY

- B. Approval of Agenda (5 minutes)

MOTION: Bradley Graham motioned to approve the agenda with changes:

New Business – F.1.h. (schedule special or emergency meeting) and Old Business, 4, will move to the end of the agenda.

SECOND: Gary Smith seconded the motion.

MOTION CARRIED UNANIMOUSLY

- C. Review\Approval of Minutes: **October 18, 2016, OPC Regular Meeting**
(Gina Buenrostro, 10 minutes)

MOTION: Gary Smith motioned to approve the October 18, 2016, OPC Regular

HANDOUT FOR ITEM - IV.A.06.a.

ONEIDA PERSONNEL COMMISSION REGULAR MEETING

November 15, 2016 – NOON

East Wing Conference Room

Meeting Minutes.

SECOND: Gary Smithy seconded the motion.

MOTION CARRIED UNANIMOUSLY

D. Tabled Business (none)

E. Old Business (4)

1. **Draft article for the Kahliwisaks (entire commission 10 minutes)**
No update
2. **Internal Audit Request-UPDATE**
No Update
3. **Employment Law Draft 21-UPDATE**
FYI only. Will schedule special meeting to address this issue
4. **Status of Complaint regarding the Area Manager of Fitness, Parks and Recreation-Update-(Entire Commission)*Carol Smith recused herself from discussion, this issue will move to the end of the agenda***

F. New Business(4)

1. **Scheduling Initial Reviews, Grievances, Reassignments and Housekeeping-(Gina Buenrostro 10 minutes)**

MOTION: Sharon Alvarez moved to go into executive session

SECOND: Pearl Webster

TIME: 12:25PM

MOTION CARRIED UNANIMOUSLY

MOTION: Bradley Graham moved to come out of executive session

SECOND: Carol Smith

TIME: 12:30PM

a. 3rd quarterly Report Status

FYI

b. Status of Attorney Sweeney Contract

MOTION: Bradley Graham moved to move this issue to the top of the Oneida Business Committee at the November 23, 2016 meeting, do not want liaison to do an E-Poll, all commissioners must attend this meeting.

SECOND: Pearl Webster

MOTION CARRIED UNANIMOUSLY

c. Status of Vacancies

FYI

d. Appoint Secretary

MOTION: Gary Smith moved to appoint Tomas Escamea as the Secretary.

HANDOUT FOR ITEM - IV.A.06.a.

ONEIDA PERSONNEL COMMISSION REGULAR MEETING

November 15, 2016 – NOON

East Wing Conference Room

SECOND: Carol Smith
MOTION CARRIED UNANIMOUSLY

e. Room (space) for Petitioners and Respondents

FYI

f. By-Laws (status)

MOTION: Pearl Webster moved to deny the request from Leland Wigg-Ninham to increase the amount of stipends.

SECOND: Gary Smith
MOTION CARRIED UNANIMOUSLY

g. Stipends

FYI

h. Schedule Special Meeting

MOTION: Pearl Webster moved to schedule special meeting to November 16, 2016 to finalize the Annual Report.

SECOND: Sharon Alvarez
MOTION CARRIED UNANIMOUSLY

2. Financial Report October 2016

MOTION: Gary Smith motioned to approve.

SECOND: Carol Smith
MOTION CARRIED UNANIMOUSLY

3. Activity Report October 2016

MOTION: Gary Smith motions to approve.

SECOND: Tomas Escamea
MOTION CARRIED UNANIMOUSLY

Old Business. 4. Status of Complaint regarding the Area Manager of Fitness, Parks and Recreation-Update-(Entire Commission)*Carol Smith recused herself from discussion, this issue will move to the end of the agenda*

MOTION: Pearl Webster moved to go into executive session.

SECOND: Sharon Alvarez
MOTION CARRIED UNANIMOUSLY

TIME: 1:16pm

MOTION: Bradley Graham to come out of executive session.

SECOND: Carol Smith
TIME: 2:06pm
MOTION CARRIED UNANIMOUSLY

HANDOUT FOR ITEM - IV.A.06.a.

ONEIDA PERSONNEL COMMISSION REGULAR MEETING

November 15, 2016 – NOON

East Wing Conference Room

MOTION: Bradley Graham moved to have the Chair send a letter to Chairwoman, Cristina Danforth requesting the status of the complaint, and to have Attorney Sweeney file a motion to consolidate cases regarding this matter with the Oneida Judiciary and also file a motion for a declaratory ruling.

SECOND: Pearl Webster

MOTION CARRIED UNANIMOUSLY

MOTION: Bradley moved to adjourn.

SECOND: Sharon Alvarez

MOTION CARRIED UNANIMOUSLY

TIME: 2:09pm

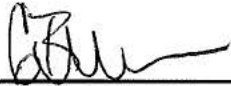

Minutes taken for the secretary by Gina Buenrostro

HANDOUT FOR ITEM - IV.A.06.a.

ONEIDA PERSONNEL COMMISSION SPECIAL/EMERGENCY MEETING
November 16, 2016 – NOON
East Wing Conference Room

Mission Statement: To develop an employment system that is orderly and fair and one that will benefit the individual worker and strengthen Tribal Programs and Tribal Government.

Secretary:

- A. Call to Order: Attendance (12:00p.m.) Gate Keeper: Yvonne Jordan, Chairwoman, called the meeting to order at 12:02p.m.

Yvonne Jourdan	Chairwoman
Gary Smith	Vice-Chair
Sharon Alvarez	Treasurer
Carol Smith	Member
Tomas Escamea	Member
Bradley Graham	Member
Pearl Webster	Member
Jennifer Hill	Member
Eric Krawczyk	Member

Also Present:

Gina Buenrostro	Administrator
Bridget Cornelius	Executive Assistant
Robert Sweeney	Attorney

EXCUSED:

Jennifer Hill	Member
Leland Wigg-Ninham	Member

UNEXCUSED:

Leland Wigg-Ninham Member

MOTION: Sharon Alvarez motioned to approve the attendance.

SECOND: Bradley Graham seconded the motion.

MOTION CARRIED UNANIMOUSLY

- B. Approval of Agenda (5 minutes)

MOTION: Eric Krawczyk motioned to approve the agenda with changes.

SECOND: Sharon Alvarez seconded the motion.

MOTION CARRIED UNANIMOUSLY

- C. **Review\Approval of Minutes:** None

- D. **Tabled Business:** None

- E. **Old Business:** None

- F. **New Business:** (3)

HANDOUT FOR ITEM - IV.A.06.a.

ONEIDA PERSONNEL COMMISSION SPECIAL/EMERGENCY MEETING

November 16, 2016 – NOON

East Wing Conference Room

1. **Oneida Personnel Commission Annual Report 2017.**

MOTION: Gary Smith moved to approve the report with the suggested changes.

SECOND: Bradley Graham

MOTION CARRIED UNANIMOUSLY

2. Meeting with the LOC regarding changes to the Administrative Court Rules

MOTION: Sharon Alvarez moved to approve the date of November 29, 2016, from 1:00 pm to 3:00 pm.

SECOND: Gary Smith

3. Sign off Authority

MOTION: Bradley Graham moved to change the sign off authority of the Chair, to Division Director status, which is 50,000 budgeted, and 10,000 unbudgeted.

SECOND: Gary Smith

MOTION CARRIED UNANIMOUSLY

MOTION: Eric Krawczyk moved to adjourn.

SECOND: Tomas Escamea

MOTION CARRIED UNANIMOUSLY

TIME: 1:05pm

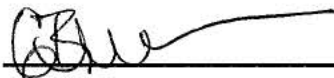

Minutes taken for the secretary by Gina Buenrostro

HANDOUT FOR ITEM - IV.A.06.a.

ONEIDA PERSONNEL COMMISSION REGULAR MEETING

December 20, 2016 – NOON

East Wing Conference Room

Mission Statement: To develop an employment system that is orderly and fair and one that will benefit the individual worker and strengthen Tribal Programs and Tribal Government.

Secretary:

- A. Call to Order: Attendance (12:00p.m.) Gate Keeper: Yvonne Jordan, Chairwoman, called the meeting to order at 12:02p.m.

Yvonne Jourdan	Chairwoman
Gary Smith	Vice-Chair
Sharon Alvarez	Treasurer
Carol Smith	Member
Tomas Escamea	Member
Bradley Graham	Member
Pearl Webster	Member
Jennifer Hill	Member
Eric Krawczyk	Member

Also Present:

Gina Buenrostro	Administrator
Bridget Cornelius	Executive Assistant
Robert Sweeney	OPC Attorney
David Jordan	OBC Liaison

EXCUSED:

Leland Wigg-Niham Member

MOTION: Bradley Graham motioned to approve the attendance excusing Leland Wigg-Ninham.

SECOND: Gary Smith seconded the motion.

MOTION CARRIED UNANIMOUSLY

- B. Approval of Agenda (5 minutes)

MOTION: Bradley Graham motioned to approve the agenda with changes:
New Business – F.l.e. Reassignment Checklist Form and F.l.f RFP for Attorney.

SECOND: Gary Smith seconded the motion.

MOTION CARRIED UNANIMOUSLY

HANDOUT FOR ITEM - IV.A.06.a.

ONEIDA PERSONNEL COMMISSION REGULAR MEETING

December 20, 2016 – NOON

East Wing Conference Room

C. Review\Approval of Minutes: November 15, 2016, OPC Regular Meeting

MOTION: Eric Krawczyk motioned to approve the November 15, 2016, OPC Regular Meeting Minutes.

SECOND: Bradly Graham seconded the motion.

MOTION CARRIED UNANIMOUSLY

Review\Approval of Minutes: November 16, 2016 OPC Special Meeting

MOTION: Pearl Webster motioned to approve the November 16, 2016, OPC Special Meeting Minutes.

SECOND: Sharon Alvarez seconded the motion.

MOTION CARRIED UNANIMOUSLY

D. Tabled Business (none)

E. Old Business (4)

1. Draft article for the Kahliwisaks

No update

2. Internal Audit Request-UPDATE

No Update

3. Employment Law Draft 21-UPDATE

FYI - Will schedule special meeting to address this issue

4. Status of Complaint regarding the Area Manager of Fitness, Parks and Recreation-Update

MOTION: Brady Graham moved to go into executive session

SECOND: Pearl Webster

TIME: 12:25PM

MOTION CARRIED UNANIMOUSLY

MOTION: Sharon Alvarez moved to come out of executive session

SECOND: Eric Krawczyk

TIME: 12:30PM

Carol Smith recused herself from discussion

F. New Business(3)

1. Scheduling Initial Reviews, Grievances, Reassignments and Housekeeping-(Gina Buenrostro 10 minutes)

MOTION: Sharon Alvarez moved to go into executive session

SECOND: Brady Graham

TIME: 12:25PM

MOTION CARRIED UNANIMOUSLY

HANDOUT FOR ITEM - IV.A.06.a.

ONEIDA PERSONNEL COMMISSION REGULAR MEETING

December 20, 2016 – NOON

East Wing Conference Room

MOTION: Gary Smith moved to come out of executive session

SECOND: Brady Graham

TIME: 12:30PM

a. 4th quarterly Report Status

MOTION: Carol Smith moved to approve quarterly report.

SECOND: Gary Smith

MOTION CARRIED UNANIMOUSLY

b. Decision Writing

FYI

c. Hearing Process and Behavior

FYI

d. Letter from HRD

FYI

e. Reassignment Checklist Form

MOTION: Pearl Webster approved the revision of the reassignment
Checklist Form

SECOND: Gary Smith

MOTION CARRIED UNANIMOUSLY

f. RFP for OPC Attorney

FYI

2. Financial Report November 2016

MOTION: Gary Smith approved the report

SECOND: Carol Smith

MOTION CARRIED UNANIMOUSLY

3. Activity Report November 2016

MOTION: Gary Smith approved the report

SECOND: Tomas Escamea

MOTION CARRIED UNANIMOUSLY

MOTION: Eric Krawczyk moved to adjourn.

SECOND: Bradley Graham

MOTION CARRIED UNANIMOUSLY

TIME: 1:55pm

Minutes taken for the secretary by Tomas Escamea

REPORT NAME: PRG_REVEXP

4273007 - PERSONNEL BOARD
 REVENUE AND EXPENSE SUMMARY
 FOR THE PERIOD ENDING: 10/31/2016

CLASS DESCRIPTION	PRT-ACCT#-SUB	CURRENT MONTH			YEAR TO DATE		
		ACTUAL	BUDGET	VARIANCE	ACTUAL	BUDGET	VARIANCE
REVENUE							
TRIBAL CONTRIBUTION	000-458100-000	19,559.17	27,677.00	8,118	19,559	27,677	8,118
TOTAL REVENUE		19,559.17	27,677.00	(8,118)	19,559	27,677	(8,118)
EXPENSES (LABOR/PAYROLL)							
PERSONNEL	000-502100-000	7,667.64	7,609.00	(59)	7,668	7,609	(59)
WAGE ACCRUAL EXPENSE	000-502100-999	(1,404.28)		1,404	(1,404)		1,404
SALARIES - TRAINING	000-502110-000	27.73		(28)	28		(28)
PAID TIME OFF	000-504000-000	1,452.64		(1,453)	1,453		(1,453)
FRINGE BENEFIT	000-505000-000	3,707.00	3,146.00	(561)	3,707	3,146	(561)
FRINGE ACCRUAL EXPENSE	000-505000-999	(585.22)		585	(585)		585
TOTAL LABOR/PAYROLL EXP.		10,865.51	10,755.00	(112)	10,867	10,755	(112)
EXPENSES (PURCHASES)							
TOTAL PURCHASES							
EXPENSES (EXTERNAL & INTERNAL)							
SUPPLIES & MATERIALS	000-700001-000	107.53	30.00	(78)	108	30	(78)
COPY CHARGES	000-700010-000		36.00	36		36	36
TRANSP. & PER DIEM	000-701000-000		163.00	163		163	163
OUTSIDE SERVICES	000-702010-000	(23.25)	67.00	90	(23)	67	90
LEGAL SERVICES	000-702400-000		3,500.00	3,500		3,500	3,500
TRAINING & EDUCATION	000-705010-000		163.00	163		163	163
RENTAL USAGE	000-705202-000	128.59	94.00	(35)	129	94	(35)
HEAT & LIGHTS	000-705211-000	229.70	375.00	145	230	375	145
WATER & SEWER	000-705212-000		5.00	5		5	5
TELEPHONE	000-705213-000	37.78	34.00	(4)	38	34	(4)
BUSINESS EXPENSE	000-705300-000		13.00	13		13	13
INSURANCE	000-705500-000	47.36	55.00	8	47	55	8
I/T SUPPLIES & MATERIALS	000-750001-000		12.00	12		12	12
I/T - PRINTING	000-750009-000		12.00	12		12	12
I/T RENT EXPENSE	000-755201-000		288.00	288		288	288
I/T UTILITIES EXPENSE	000-755210-000	.08					
I/T DEPRECIATION ALLOCATION	000-755216-000	286.87		(287)	287		(287)
INDIRECT COSTS	000-758300-000	1,500.25	1,204.00	(296)	1,500	1,204	(296)
INDIRECT COST ACCRUAL EXPENSE	000-758300-999	(221.25)		221	(221)		221

REPORT NAME: PRG_REVEXP

4273007 - PERSONNEL BOARD
 REVENUE AND EXPENSE SUMMARY
 FOR THE PERIOD ENDING: 10/31/2016

CLASS DESCRIPTION	PRT-ACCNT#-SUB	CURRENT MONTH			YEAR TO DATE		
		ACTUAL	BUDGET	VARIANCE	ACTUAL	BUDGET	VARIANCE
STIPENDS	100-705305-000	2,500.00	6,731.00	4,231	2,500	6,731	4,231
STIPENDS	400-705305-000	500.00	688.00	188	500	688	188
STIPENDS	500-705305-000	2,900.00	2,902.00	2	2,900	2,902	2
STIPENDS	600-705305-000	700.00	550.00	(150)	700	550	(150)
TOTAL EXT./INT. EXPENSES		8,693.66	16,922.00	8,227	8,695	16,922	8,227
TOTAL EXPENSES		19,559.17	27,677.00	8,115	19,562	27,677	8,115
NET TOTALS					(3)		(3)

REPORT NAME: PRG_REVEXP

4273007 - PERSONNEL BOARD
 REVENUE AND EXPENSE SUMMARY
 FOR THE PERIOD ENDING: 11/30/2016

CLASS DESCRIPTION	PRT-ACCNT#-SUB	CURRENT MONTH			YEAR TO DATE		
		ACTUAL	BUDGET	VARIANCE	ACTUAL	BUDGET	VARIANCE
REVENUE							
TRIBAL CONTRIBUTION	000-458100-000	21,765.22	-27,678.00	5,913	41,324	55,355	14,031
TOTAL REVENUE		21,765.22	27,678.00	(5,913)	41,324	55,355	(14,031)
EXPENSES (LABOR/PAYROLL)							
PERSONNEL	000-502100-000	5,810.39	7,606.00	1,796	13,478	15,215	1,737
WAGE ACCRUAL EXPENSE	000-502100-999	728.60		(729)	(676)		676
SALARIES - TRAINING	000-502110-000				28		(28)
PAID TIME OFF	000-504000-000	1,508.02		(1,508)	2,961		(2,961)
FRINGE BENEFIT	000-505000-000	2,965.61	3,141.00	175	6,673	6,287	(386)
FRINGE ACCRUAL EXPENSE	000-505000-999	296.14		(296)	(289)		289
TOTAL LABOR/PAYROLL EXP.		11,308.76	10,747.00	(562)	22,175	21,502	(673)
EXPENSES (PURCHASES)							
TOTAL PURCHASES							
EXPENSES (EXTERNAL & INTERNAL)							
SUPPLIES & MATERIALS	000-700001-000	416.22	30.00	(386)	524	60	(464)
COPY CHARGES	000-700010-000		34.00	34		70	70
TRANSP. & PER DIEM	000-701000-000		167.00	167		330	330
OUTSIDE SERVICES	000-702010-000	12.71	63.00	50	(11)	130	141
LEGAL SERVICES	000-702400-000		3,500.00	3,500		7,000	7,000
TRAINING & EDUCATION	000-705010-000		167.00	167		330	330
RENTAL USAGE	000-705202-000	128.59	96.00	(33)	257	190	(67)
HEAT & LIGHTS	000-705211-000	243.84	375.00	131	474	750	276
WATER & SEWER	000-705212-000	18.11	5.00	(13)	18	10	(8)
TELEPHONE	000-705213-000	32.99	36.00	3	71	70	(1)
BUSINESS EXPENSE	000-705300-000		17.00	17		30	30
INSURANCE	000-705500-000	47.36	55.00	8	95	110	15
I/T SUPPLIES & MATERIALS	000-750001-000		8.00	8		20	20
I/T - PRINTING	000-750009-000		8.00	8		20	20
I/T RENT EXPENSE	000-755201-000		292.00	292		580	580
I/T UTILITIES EXPENSE	000-755210-000	.08					
I/T DEPRECIATION ALLOCATION	000-755216-000	286.87		(287)	574		(574)
INDIRECT COSTS	000-758300-000	1,200.20	1,209.00	9	2,700	2,413	(287)
INDIRECT COST ACCRUAL EXPENSE	000-758300-999	119.49		(119)	(102)		102

273007 - PERSONNEL BOARD
 STATEMENTS PRODUCED PRIOR TO PERIOD CLOSING DATES ARE SUBJECT TO CHANGE
 REPORT RUNDATE/TIME: 12/13/2016 11:12:00 ONEIDA TRIBE OF INDIANS OF WISCONSIN

HANDOUT FOR ITEM - IV.A.06.a.

CBRONE01
 02NOV/2017

REPORT NAME: PRG_REVEXP

4273007 - PERSONNEL BOARD
 REVENUE AND EXPENSE SUMMARY
 FOR THE PERIOD ENDING: 11/30/2016

CLASS DESCRIPTION	PRT-ACCNT#-SUB	CURRENT MONTH			YEAR TO DATE		
		ACTUAL	BUDGET	VARIANCE	ACTUAL	BUDGET	VARIANCE
STIPENDS	100-705305-000	3,250.00	6,729.00	3,479	5,750	13,460	7,710
STIPENDS	200-705305-000	350.00		(350)	350		(350)
STIPENDS	400-705305-000	400.00	692.00	292	900	1,380	480
STIPENDS	500-705305-000	3,700.00	2,898.00	(802)	6,600	5,800	(800)
STIPENDS	600-705305-000	250.00	550.00	300	950	1,100	150
TOTAL EXT./INT. EXPENSES		10,456.46	16,931.00	6,475	19,150	33,853	14,703
TOTAL EXPENSES		21,765.22	27,678.00	5,913	41,325	55,355	14,030
NET TOTALS					(1)		(1)

REPORT NAME: PRG_REVEXP

4273007 - PERSONNEL BOARD
REVENUE AND EXPENSE SUMMARY
FOR THE PERIOD ENDING: 12/31/2016

CLASS DESCRIPTION	PRT-ACCNT#-SUB	CURRENT MONTH			YEAR TO DATE		
		ACTUAL	BUDGET	VARIANCE	ACTUAL	BUDGET	VARIANCE
REVENUE							
TRIBAL CONTRIBUTION	000-458100-000	19,515.42	27,678.00	8,163	60,840	83,033	22,193
TOTAL REVENUE		19,515.42	27,678.00	(8,163)	60,840	83,033	(22,193)
EXPENSES (LABOR/PAYROLL)							
PERSONNEL	000-502100-000	6,813.89	7,606.00	792	20,292	22,821	2,529
WAGE ACCRUAL EXPENSE	000-502100-999	(1,097.35)		1,097	(1,773)		1,773
SALARIES - TRAINING	000-502110-000				28		(28)
PAID TIME OFF	000-504000-000	2,378.48		(2,378)	5,339		(5,339)
FRINGE BENEFIT	000-505000-000	3,712.35	3,141.00	(571)	10,385	9,428	(957)
FRINGE ACCRUAL EXPENSE	000-505000-999	(444.80)		445	(734)		734
TOTAL LABOR/PAYROLL EXP.		11,362.57	10,747.00	(615)	33,537	32,249	(1,288)
EXPENSES (PURCHASES)							
TOTAL PURCHASES							
EXPENSES (EXTERNAL & INTERNAL)							
SUPPLIES & MATERIALS	000-700001-000		30.00	30	524	90	(434)
COPY CHARGES	000-700010-000	277.18	34.00	(243)	277	104	(173)
TRANSP. & PER DIEM	000-701000-000		167.00	167		497	497
OUTSIDE SERVICES	000-702010-000		63.00	63	(11)	193	204
LEGAL SERVICES	000-702400-000		3,500.00	3,500		10,500	10,500
TRAINING & EDUCATION	000-705010-000		167.00	167		497	497
RENTAL USAGE	000-705202-000	128.59	96.00	(33)	386	286	(100)
HEAT & LIGHTS	000-705211-000	88.16	375.00	287	562	1,125	563
WATER & SEWER	000-705212-000	9.07	5.00	(4)	27	15	(12)
TELEPHONE	000-705213-000	37.97	36.00	(2)	109	106	(3)
BUSINESS EXPENSE	000-705300-000		17.00	17		47	47
INSURANCE	000-705500-000	47.36	55.00	8	142	165	23
I/T SUPPLIES & MATERIALS	000-750001-000		8.00	8		28	28
I/T - PRINTING	000-750009-000		8.00	8		28	28
I/T RENT EXPENSE	000-755201-000		292.00	292		872	872
I/T UTILITIES EXPENSE	000-755210-000	.09					
I/T DEPRECIATION ALLOCATION	000-755216-000	286.87		(287)	861		(861)
INDIRECT COSTS	000-758300-000	1,507.53	1,209.00	(299)	4,208	3,622	(586)
INDIRECT COST ACCRUAL EXPENSE	000-758300-999	(179.97)		180	(282)		282

273007 - PERSONNEL BOARD
 STATEMENTS PRODUCED PRIOR TO PERIOD CLOSING DATES ARE SUBJECT TO CHANGE
 REPORT RUNDATE/TIME: 1/12/2017 11:10:08 ONEIDA TRIBE OF INDIANS OF WISCONSIN

HANDOUT FOR ITEM IV.A.06.a.

03DEC/2017

REPORT NAME: PRG_REVEXP

4273007 - PERSONNEL BOARD
 REVENUE AND EXPENSE SUMMARY
 FOR THE PERIOD ENDING: 12/31/2016

CLASS DESCRIPTION	PRT-ACNT#-SUB	CURRENT MONTH			YEAR TO DATE		
		ACTUAL	BUDGET	VARIANCE	ACTUAL	BUDGET	VARIANCE
STIPENDS	100-705305-000	2,750.00	6,729.00	3,979	8,500	20,189	11,689
STIPENDS	200-705305-000				350		(350)
STIPENDS	400-705305-000	450.00	692.00	242	1,350	2,072	722
STIPENDS	500-705305-000	2,650.00	2,898.00	248	9,250	8,698	(552)
STIPENDS	600-705305-000	100.00	550.00	450	1,050	1,650	600
TOTAL EXT./INT. EXPENSES		8,152.85	16,931.00	8,778	27,303	50,784	23,481
TOTAL EXPENSES		19,515.42	27,678.00	8,163	60,840	83,033	22,193
NET TOTALS							

*Celebrate
with us on*

ONEIDA NATION Code Talkers' Day

5.26.17

ENTRY \$60

- 4-person "blind-draw" scramble
- 8 am shotgun start
- \$60 entry fee per player (includes: driving range, green fees, cart, lunch, shag bag and awards)
- EXTRAS: Skin Game, Raffle, Hole Events

ONEIDA NATION Code Talkers' Day GOLF OUTING

FRI // 26 // MAY // 2017

Thornberry Creek at Oneida

Call us for more details **920-562-7536**



HOSTED BY

ONEIDA NATION VETERANS AFFAIRS COMMITTEE

FIRST 144 PAID ENTRIES WILL BE ABLE TO PLAY

REGISTER NOW
2017 ONEIDA NATION
Code Talkers' Day
GOLF OUTING 5.26.17

Name

Veteran: Yes No Gender: M F Age:

Tribal Affiliation:

Phone:

Drop off completed entry with fee at the Oneida Veteran's Service Office
134 Riverdale Dr, Oneida, WI 54155



Oneidas bringing several hundred bags of corn to Washington's starving army at Valley Forge, after the colonists had consistently refused to aid them.

Oneida Nation

Post Office Box 365

Phone: 920-869-2214



Oneida, WI 54155



UGWA DEMOLUM YATEHE
Because of the help of this Oneida Chief in cementing a friendship between the six nations and the colony of Pennsylvania, a new nation, the United States was made possible.

Business Committee Members,

The Oneida Land Claims Commission (OLCC) seeks the support of the Oneida Business Committee to direct the LOC to review the OLCC updated bylaws as soon as possible. The OLCC was formed as a result of a GTC directive to work with the OBC on the Oneida Nation Land Claims issue and report back to the GTC. The revised OLCC bylaws include an improved vision and mission statement which is essential in order to move forward with our strategic plan that we have discussed with you the BC.

Jennifer Falck of LOC said we should wait until the amended changes to the comprehensive policy governing boards, committees, and commissions are complete so we would not have to resubmit amendments to our bylaws if they don't comply with potential future changes. However, the OLCC takes no problem with making any required needed changes after the approved amendments to the comprehensive policy governing boards, committees, and commissions are made.

The commission has been working on the OLCC bylaws for quite some time and it is imperative for us to have these approved bylaws in order to continue to move forward with our new strategy; collaboratively working together toward a comprehensive recommendation and resolution for the Oneida Nation.

Jennifer sent the OLCC an email stating, *"I spoke to Brandon about the Land Claims Bylaws amendments. We are in agreement that bylaws will not be processed until after the Comprehensive Policy Governing Boards, Committees, and Commissions is amended and approved. The LOC has indicated the same thing to other boards, committees, and commissions as well. We also had some discussion- that Land Claims may want to work with the Business Committee if there are to be changes in the current activities."* The OLCC is not in agreement with this delay.

The OLCC would like to avoid all unnecessary delays in the Oneida Nation's assertion to all Land Claim matters, as this may impact the outcome of all our claims (Doctrine of Laches). Therefore we are requesting your assistance to move forward with your support to update our bylaws and our request for immediate LOC review.

Respectfully,

Oneida Land Claims Commission

Business Committee Meeting
8:00 a.m. Wednesday, April 27, 2017
Thank you for printing clearly

Carol L Elm _____
Tamara Van Schynkel _____
Cheryl Wilson _____
Gene Schubert _____
Sandra Reveles _____
Tonya Webster _____
Barb Erickson _____
Lop Strong _____
Cot Jossila _____
Lois Powless _____
Joleke Hensberger _____
Janie Holt _____
Dora Skowron _____

